



LSLV

Fan and Pump AC Drive **iP5A**

0.75~30kW(1~40HP) 3-Phase 200~230V
0.75~450kW(1~700HP) 3-Phase 380~480V
5.5~110kW(7.5~150HP) 3-Phase 525~600V



LSIS

LS 021-88469004
09106611367
WWW.LSKALA.COM

STARVERT iP5A

LS Starvert SV-iP5A has been specifically designed and created to provide competitive solutions for fan and pump applications



Specialized
Functions for
Fan and Pump

Marine Type
Certification
From DNV

Energy
Saving and High
Efficiency

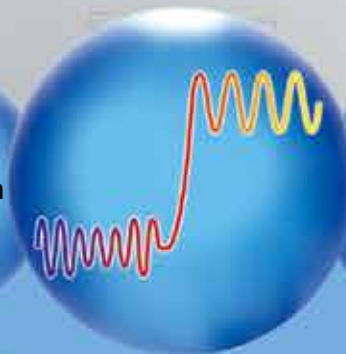

User-friendly
Interface
and Easy
Maintenance

Intelligent
Control
Mechanism

STARVERT iP5A

Contents

4	Overview
8	Model & Type
9	Standard Specifications
13	Wiring
17	Terminal Configurations (Power Circuit Terminal)
19	Terminal Configurations (Control Circuit Terminal)
22	Programming Keypad
23	Programming Keypad (Parameter Navigation)
24	Parameter Description
37	Trial Run
39	Dimensions
45	DB (Dynamic Braking) Unit
50	External DB Resistor / Peripheral Device



Specialized Functions for Fan and Pump

The iP5A, specifically designed for HVAC application, provides stable and cost-effective system performance.



PID Control

In the centrifugal fan and pump field, PID control is provided as a standard function in order to maintain a constant control of pressure, flow and oil level. This function includes Pre-PID, Sleep and Wake up and output inverse sub-functions.

Dual PID

Where external or cascaded PID control is required, the built-in dual PID algorithm of the iP5A can be utilized to satisfy various system requirements.

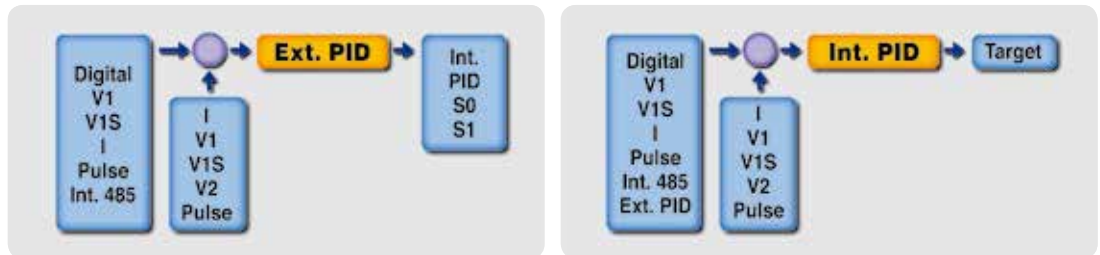

Multi Motor Control (0.75~450kW)

The iP5A MMC function provides cost-effective, simultaneous control of up to eight motors, without requiring external controllers.

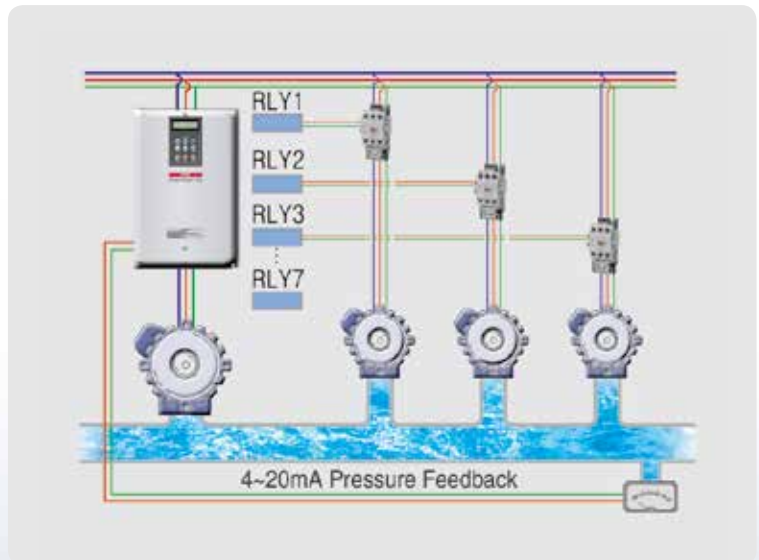

Marine Type Certification From DNV

The iP5A has been tested and certified by DNV to comply with International Marine requirements

Energy Saving and High Efficiency

The iP5A, specifically designed for fan and pump applications, guarantees energy savings by optimizing the system.



Sleep and Wake-up Function

Energy savings are obtained through the Sleep and Wake-Up functions of the iP5A, which enable the drive to automatically switch off during user-programmed low-load conditions and then to start up again when process demand increases.

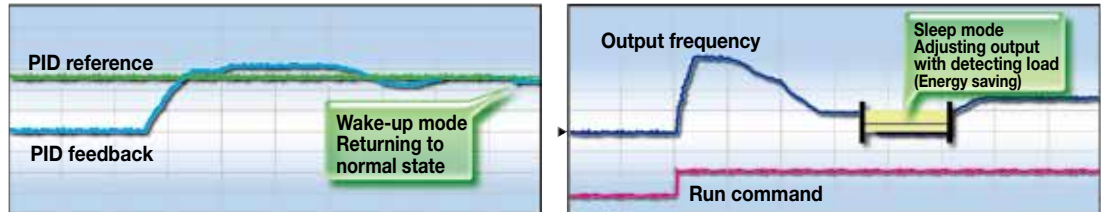

Pre Heating Function

When using the drive in damp conditions, this function protects both the motor and the drive's output



Flying Start Function

When 2 or more fans, or a high inertia load are connected to the drive, the iP5A detects the motor speed after a momentary power failure, enabling the motors to be smoothly reaccelerated without mechanical and electrical shock-loading to the system.



Automatic Energy Saving

Load change may incur energy losses but the optimized flux control of iP5A results in more outstanding energy saving compared to previous models.

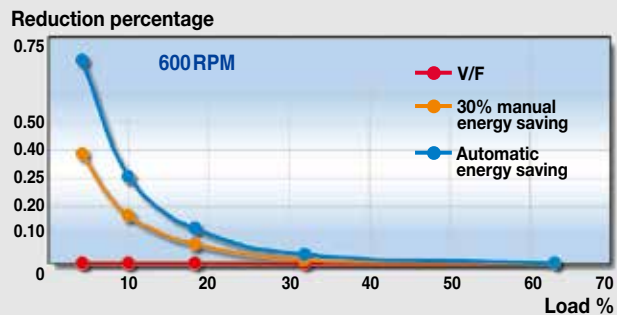
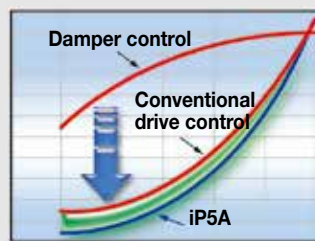

Intelligent Control

Because of effectual functions and protection algorithms, the iP5A provides constant performance, in spite of external power fluctuations.



Constant and Stable Performance

In spite of external voltage fluctuations and lightning surges, the iP5A optimizes motor performance.



Improved System Management during Power Dips and Momentary Power Outages

During Power Dips or Momentary Power Outage, the drive output can be maintained by utilizing the residual mechanical energy in the load as a regenerative source. The duration of the power-dip ride-through depends on the load characteristics.

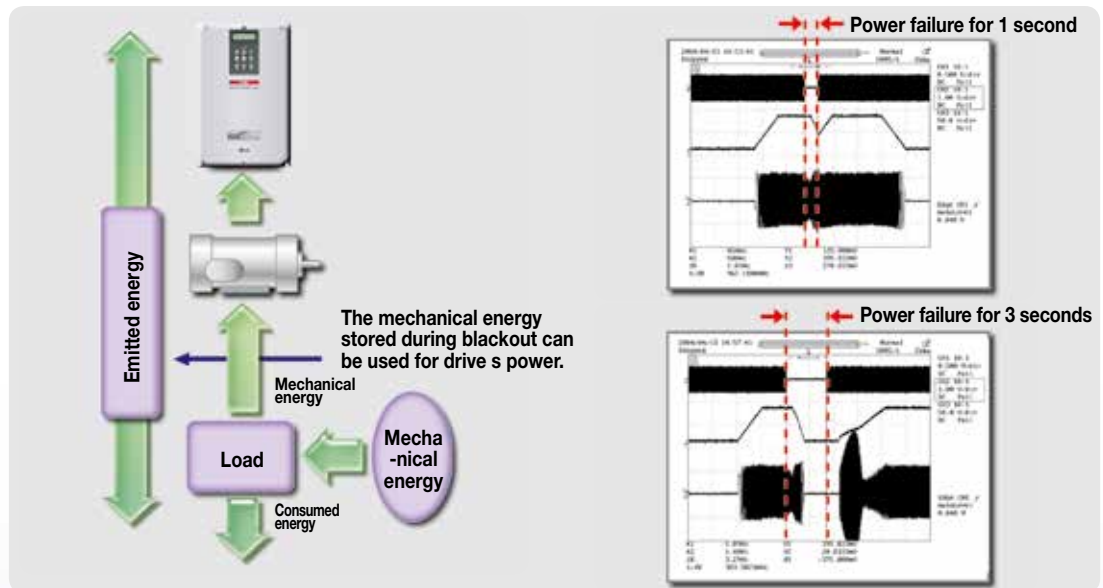

Safety Stop

During unexpected power failure conditions, the iP5A can bring the load to a controlled stop, by utilizing the inertial energy. This can prevent further process problems or accidents.



Current Leakage Reduction Algorithm

Under damp conditions, leakage currents can occur when using drives. These currents can cause a system failure. The iP5A low-leakage PWM algorithm reduces these leakage currents to ensure reliability of operation.

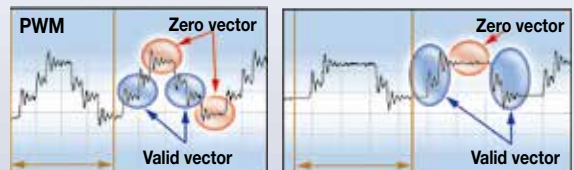

Flux Braking Algorithm

This algorithm reduces deceleration time, thereby improving system efficiency.



Automatic Carrier Frequency Change

By taking ambient temperature into account, the iP5A can automatically adjust the Carrier (Modulation) Frequency.



Protection

The iP5A has optimized protective functions, such as safety stop and pre-excitation of the motor, amongst others.

User-friendly Keypad & Easy Maintenance

The iP5A construction allows for easy maintenance, with ease-of-access to all components.

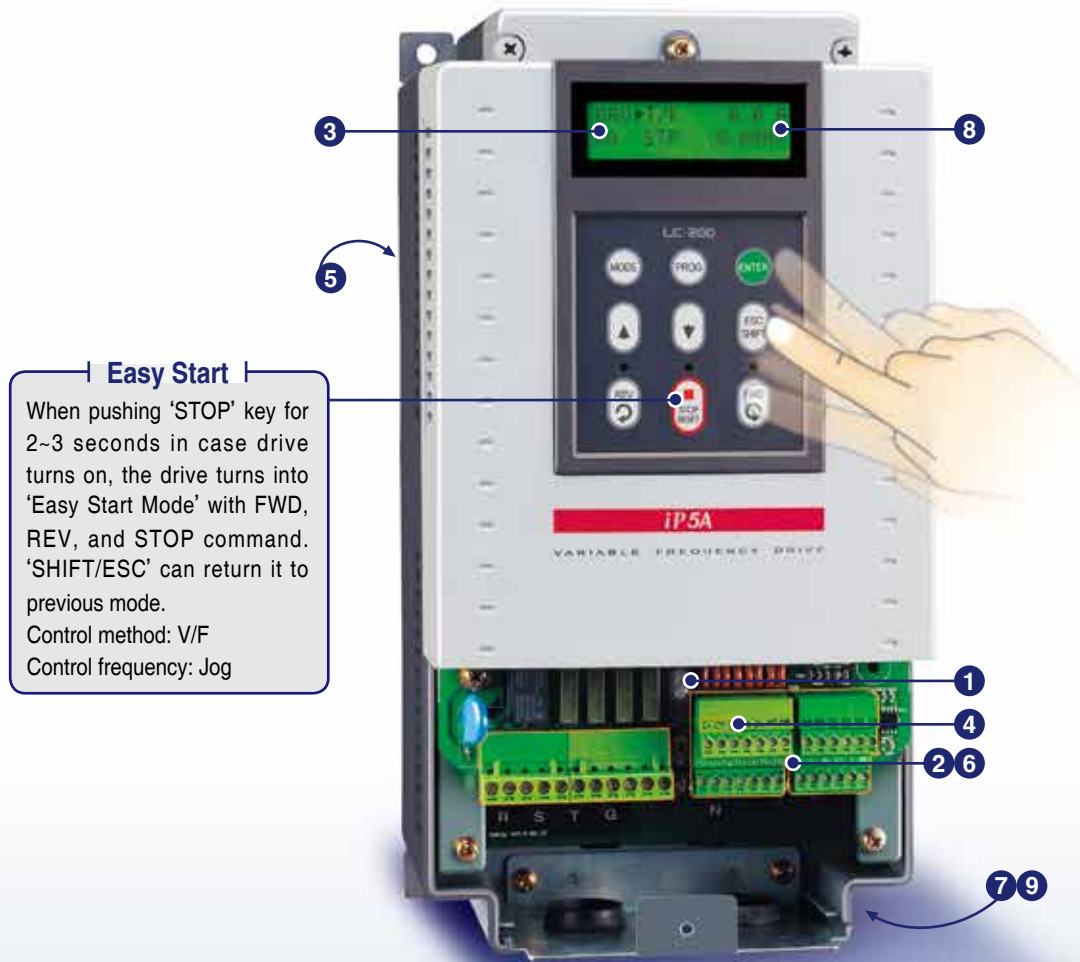

Easy Start

When pushing 'STOP' key for 2~3 seconds in case drive turns on, the drive turns into 'Easy Start Mode' with FWD, REV, and STOP command. 'SHIFT/ESC' can return it to previous mode.
Control method: V/F
Control frequency: Jog

1 NPN/PNP Input

iP5A has both NPN and PNP input, and you can select one of them easily.

2 Abundant I/O Suggestion

iP5A serves abundant I/O.

Digital Input/Output	8 points / 4 points
Analog Input (Voltage + Current)/Output	(1+1) points /4 points
Pulse Input	1 point
NTC/PTC Input	1 point

3 Various Units of I/O Display

The iP5A display can be calibrated in many different types of process units.

DRV_REF 500.0mBa 15 FBK 82.1mBa	DRV_REF 500.0kPa 15 FBK 82.1kPa
------------------------------------	------------------------------------

4 Built-in RS485 and Optional Communication

The built-in RS485 allows for communication without external option. However, the optional communication boards enable the iP5A to talk to BMS and most Industrial Systems

5 Long-life Condenser and Simple Framework

iP5A adopts long-life condenser and enables easy maintenance in simple framework.

6 Consumption Time Display

iP5A displays consumption time of components so that users can replace them in time.

7 Others

- Removable terminal board
- External fan available
- Cooling fan on/off control

iP5A

Model & Type



Motor Rating	200~230V Class	380~480V Class	380~480V Class (Classification)	525~600V Class
0.75kW (1HP)	SV008iP5A-2NE	SV008iP5A-4NE		
1.5kW (2HP)	SV015iP5A-2NE	SV015iP5A-4NE		
2.2kW (3HP)	SV022iP5A-2NE	SV022iP5A-4NE		
3.7kW (5HP)	SV037iP5A-2NE	SV037iP5A-4NE		
5.5kW (7.5HP)	SV055iP5A-2NE	SV055iP5A-4NE	SV055iP5A-4NE (CLASS)	SV055iP5A-6
7.5kW (10HP)	SV075iP5A-2NE	SV075iP5A-4NE	SV075iP5A-4NE (CLASS)	SV075iP5A-6
11kW (15HP)	SV110iP5A-2NE	SV110iP5A-4NE	SV110iP5A-4NE (CLASS)	SV110iP5A-6
15kW (20HP)	SV150iP5A-2NO	SV150iP5A-4NO	SV150iP5A-4NOL (CLASS)	SV150iP5A-6
18.5kW (25HP)	SV185iP5A-2NO	SV185iP5A-4NO	SV185iP5A-4NOL (CLASS)	SV185iP5A-6
22kW (30HP)	SV220iP5A-2NO	SV220iP5A-4NO	SV220iP5A-4NOL (CLASS)	SV220iP5A-6
30kW (40HP)	SV300iP5A-2NO	SV300iP5A-4NO	SV300iP5A-4NOL (CLASS)	SV300iP5A-6
37kW (50HP)		SV370iP5A-4O	SV370iP5A-4OL (CLASS)	SV370iP5A-6
45kW (60HP)		SV450iP5A-4O	SV450iP5A-4OL (CLASS)	SV450iP5A-6
55kW (75HP)		SV550iP5A-4O	SV550iP5A-4OL (CLASS)	SV550iP5A-6
75kW (100HP)		SV750iP5A-4O	SV750iP5A-4OL (CLASS)	SV750iP5A-6
90kW (125HP)		SV900iP5A-4O	SV900iP5A-4OL (CLASS)	SV900iP5A-6
110kW (150HP)		SV1100iP5A-4OL	SV1100iP5A-4OL (CLASS)	SV1100iP5A-6
132kW (200HP)		SV1320iP5A-4OL	SV1320iP5A-4OL (CLASS)	
160kW (250HP)		SV1600iP5A-4OL	SV1600iP5A-4OL (CLASS)	
220kW (300HP)		SV2200iP5A-4OL	SV2200iP5A-4OL (CLASS)	
280kW (350HP)		SV2800iP5A-4OL	SV2800iP5A-4OL (CLASS)	
315kW (400HP)		SV3150iP5A-4O	SV3150iP5A-4O (CLASS)	
375kW (500HP)		SV3750iP5A-4O	SV3750iP5A-4O (CLASS)	
450kW (600HP)		SV4500iP5A-4O	SV4500iP5A-4O (CLASS)	

SV

055

Motor Rating	
055	5.5 kW
900	90 kW

iP5A

Series Name	
iP5A	

-

2

Input Voltage	
2	200-230V
4	380-480V
6	525-600V

NE

N:	No Keypad
O:	UL Open Type
E:	UL Enclosed Type 1
L:	Built-in DC Reactor <small>(15-90kW : Option / 110-280kW : Standard)</small>

(CLASS)

Classification	

SV055iP5A-2NE

← Model Number	
← Input Rating	INPUT 200-230 V 3 Phase 25A 50/60HZ
← Output Rating	OUTPUT 0-Input V 3 Phase 24A 0.01-120HZ
← Protection Degree	9.1KVA, Enclosed Type 1
← Bar Cord	
← Serial Number	90204000408

LS Industrial Systems Co., Ltd. Made in Korea



Marine Approved Drives
needs additional ordering.

Standard Specifications

■ 200~230V Class (0.75~30kW / 1~40HP)

Model Number (SV □□□ iP5A-2)			008	015	022	037	055	075	110	150	185	220	300	
Capacity [kVA] ^{Note1}			1.9	3.0	4.6	6.1	9.1	12.2	17.5	22.9	28.2	33.5	43.8	
Fan or pump load	Motor rating ^{Note2}	(HP)	1	2	3	5	7.5	10	15	20	25	30	40	
		(kW)	0.75	1.5	2.2	3.7	5.5	7.5	11	15	18.5	22	30	
	Current [A]		5	8	12	16	24	32	46	60	74	88	115	
	(110% over current)		110% 1 Minute (Normal Duty)											
Output ratings	General load	Motor rating	(HP)	0.5	1	2	3	5	7.5	10	15	20	25	30
			(kW)	0.4	0.75	1.5	2.2	3.7	5.5	7.5	11	15	18.5	22
		Current [A]		2.5	5	8	12	17	23	33	44	54	68	84
		(150% over current)		150% 1 Minute (Heavy Duty)										
	Frequency		0.01~120 Hz											
	Voltage		200~230V ^{Note3}											
Input ratings	Voltage		3Ø200~230V (-15%~+10%)											
	Frequency		50/60 Hz (± 5%)											
Protection degree			IP20 / UL Type1						IP00 / UL Open ^{Note4}					
Weight [kg (lbs.)]			4.1(9.0)	4.2(9.3)	4.2(9.3)	4.9(10.8)	4.9(10.8)	6(13.2)	6(13.2)	13(28.7)	13.5(29.8)	20(44.1)	20(44.1)	

■ 380~480V Class (0.75~90kW / 1~125HP)

Model Number (SV □□□ iP5A-4)			008	015	022	037	055	075	110	150	185	220	300	370	450	550	750	900		
Capacity [kVA] ^{Note1}			2.0	3.2	4.8	6.4	9.6	12.7	19.1	23.9	31.1	35.9	48.6	59.8	72.5	87.6	121.1	145.8		
Fan or pump load	Motor rating ^{Note2}	(HP)	1	2	3	5	7.5	10	15	20	25	30	40	50	60	75	100	125		
		(kW)	0.75	1.5	2.2	3.7	5.5	7.5	11	15	18.5	22	30	37	45	55	75	90		
	Current [A]		2.5	4	6	8	12	16	24	30	39	45	61	75	91	110	152	183		
	(110% over current)		110% 1 Minute (Normal Duty)																	
Output ratings	General load	Motor rating	(HP)	0.5	1	2	3	5	7.5	10	15	20	25	30	40	50	60	75	100	
			(kW)	0.4	0.75	1.5	2.2	3.7	5.5	7.5	11	15	18.5	22	30	37	45	55	75	
		Current [A]		1.25	2.5	4	6	8.8	12	16	22/24	28/30	34/39	44/45	-	-	-	-	-	
		(150% over current)		150% 1 Minute (Heavy Duty)																
	Frequency		0.01~120 Hz																	
	Voltage		380~480V ^{Note3}																	
Input ratings	Voltage		3Ø380~480V (-15%~+10%)																	
	Frequency		50/60 Hz (± 5%)																	
Protection degree			IP20 / UL Type1						IP00 / UL Open ^{Note4}											
Weight [kg (lbs.)]	Standard Type		4.1(9.0)	4.2(9.3)	4.2(9.3)	4.9(10.8)	4.9(10.8)	6(13.2)	6(13.2)	12.5(27.6)	13(28.7)	20(44.1)	20(44.1)	27(59.5)	27(59.5)	29(64)	42(92.6)	43(94.8)		
	Built-in DCL Type		-	-	-	-	-	-	-	19.5(43.9)	19.5(42.9)	26.5(58.3)	26.5(58.3)	39(86)	40(88.2)	42(92.6)	67(147.4)	68(149.9)		

^{Note 1} Rated capacity (v 3Ø□□V□□) is based on 220V for 200V class and 460V for 400V class. ² Indicates the maximum applicable capacity when using a 4-Pole LS motor.
³ Maximum output voltage will not exceed the input voltage. An output voltage less than the input voltage may be programmed if necessary.
⁴ IP20/UL Type1 with optional conduit, it can be modified to UL Type1.

iP5A

Standard Specifications

■ 380~480V Class (110~450kW / 50~125HP)

Model Number (SV □□□□ iP5A-4)			1100	1320	1600	2200	2800	3150	3750	4500		
Capacity [kVA] ^{Note1)}			178	210	259	344	436	488	582	699		
Output ratings	Fan or pump load	Motor rating ^{Note2)} (HP)	150	200	250	350	400	500	600	700		
			(kW)	110	132	160	220	280	315	375	450	
		Current [A]		223	264	325	432	547	613	731	877	
		(110% over current)		110% 1 Minute (Normal Duty)								
	General load	Motor rating (HP)	125	150	200	250	350	400	500	600		
			(kW)	90	110	132	160	220	280	315	375	
		Current [A]		183	223	264	325	432	547	613	731	
		(150% over current)		150% 1 Minute (Heavy Duty)								
	Frequency			0.01~120 Hz								
	Voltage			380~480V ^{Note3)}								
Input ratings	Voltage			3Ø380~480V (-15%~+10%)								
	Frequency			50/60 Hz (± 5%)								
Protection degree			IP00 / UL Open ^{Note4)}									
DCL			Built-in						External Option			
Weight [kg (lbs.)]			101 (222.7)	101 (222.7)	114 (251.3)	200 (441.9)	200 (441.9)	243 (535.7)	380 (837.7)	380 (837.7)		

■ 525~600V Class (5.5~110kW / 7.5~150HP)

Model Number (SV □□□□ iP5A-6)			055	075	110	150	185	220	300	370	450	550	750	900	1100		
Capacity [kVA]			9.6	12.7	19.1	23.9	31.1	35.9	48.6	59.8	72.5	87.6	121.1	145.8	178		
Output ratings	Fan or pump load	Motor rating (HP)	7.5	10	15	20	25	30	40	50	60	75	100	125	150		
			(kW)	5.5	7.5	11	15	18.5	22	30	37	45	55	75	90	110	
		Current [A]		9	12	17	23	27	34	43	55	64	80	104	128	150	
		(110% over current)		110% 1Minute (Normal Duty)													
	General load	Motor rating (HP)	5.5	7.5	10	15	20	25	30	40	50	60	75	100	125		
			(kW)	3.7	5.5	7.5	11	15	18.5	22	30	37	45	55	75	90	
		Current [A]		6.1	9	12	17	23	27	34	43	55	64	80	104	128	
		(150% over current)		150% 1 Minute (Heavy Duty)													
	Frequency			0.01~120 Hz													
	Voltage			525 ~600V ^{Note3)}													
Input ratings	Voltage			3f 525~600V (-15% ~ +10 %)													
	Frequency			50/60 Hz (± 5 %)													
Protection degree			IP20 / UL Type1						IP00 / UL Open ^{Note4)}								
Weight [kg (lbs.)]		Standard Type	6.5 (14.4)	7.0 (15.5)	7.0 (15.5)	11.7 (25.8)	11.7 (25.8)	18.9 (41.7)	18.9 (41.7)	32 (70.65)	32 (70.65)	32 (70.65)	46 (101.5)	46 (101.5)	101 (223)		

Note 1) Rated capacity (v 3 X V X I) is based on 220V for 200V class and 460V for 400V class. 2) Indicates the maximum applicable capacity when using a 4-Pole LS motor.
 3) Maximum output voltage will not exceed the input voltage. An output voltage less than the input voltage may be programmed if necessary.
 4) IP20/UL Type1 with optional conduit, it can be modified to UL Type1.

■ ■ Common Specifications

Control	Cooling method		Forced air cooling (Self-cooling for below 1.5kW-2, 2.2kW-4)
	Control Method		V/F, Sensorless Vector, Slip Compensation, Easy Start Selectable
	Frequency Setting Resolution		Digital Reference: 0.01 Hz (Below 100 Hz), 0.1 Hz (Over 100 Hz) Analog Reference: 0.01 Hz / 60 Hz
	Frequency Accuracy		Digital: 0.01% of the max frequency Analog: 0.1% of the max frequency
	V/F Pattern		Linear, Squared Pattern, User V/F
	Overload Capacity		110% per 1 min, 120% per 1 min ^{Notes)}
	Torque Boost		Manual Torque Boost (0 ~ 15 %), Auto Torque Boost
Operation	Operation Method		Keypad / Terminal / Communication Operation
	Frequency Setting		Analog: 0 ~ 12V / -12V ~ 12V / 0~20mA/ Pulse / Ext-PID Digital: Keypad
	Input Signal	Start Signal	Forward, Reverse
		Multi-Step	Up to 18 Speeds can be set including Jog (Use Programmable Digital Input Terminal, Including Jog/Dwell)
		Multi Step Accel/Decel Time	0.1~ 6,000 sec, Max 4 types can be set via Multi- Function Terminal. Accel/Decel Pattern: Linear, U-Curve, S-Curve Selectable
		Emergency Stop	Interrupts the Output of Drive
		Jog	Jog Operation
		Fault Reset	Fault Reset
	Output signal	Operating Status	Frequency Detection Level, Overload Alarm, Stalling, Over Voltage, Low Voltage, Drive Overheating/ Running/ Stopping/ Constant running, Drive By-Pass, Speed Searching
		Fault Output	Contact Output (3A, 3C, 3B) - AC 250V 1A, DC 30V 1A
		Indicator	Choose 2 from Output Frequency, Output Current, Output Voltage, DC Link Voltage (Output Voltage: 0 ~ 10V)
Operation Function		DC Braking, Frequency Limit, Frequency Jump, 2 nd Function, Slip Compensation, Reverse Rotation Prevention, Auto Restart, Invert By-Pass Auto-Tuning PID Control Start Stop Braking leakage Pre-PID Dual-PID MMC Start Prer By Pass, Auto Tuning, Control, Flying Start, Safety Stop, Flux Braking, Low leakage, Pre PID, Dual PID, MMC, Easy Start, e-heater	
Protection	Drive Trip		Over Voltage, Low Voltage, Over Current, Ground Fault, Drive Overheat, Motor Overheat, Output Phase Open, Overload Protection, External Fault 1, 2, Communication Error, Loss of Speed Command, Hardware Fault, Option Fault etc
	Drive Alarm		Stall Prevention, Overload Alarm, Thermal Sensor Fault
Display	Keypad	Operation Information	Output Frequency, Output Current, Output Voltage, Frequency Set Value, Operating Speed, DC Voltage, Integrating Wattmeter, Fan ON time, Run-time, Last Trip Time
		Trip Information	Trips Indication when the Protection Function activates. Max. 5 Faults are saved. Last Trip Time.
Environment	Ambient Temperature		-10°C ~ 50°C (14°F ~ 122°F) Decrease 2% of rated current for every 1°C increase in above 40°C
	Storage Temperature		-20°C ~ 65°C (-4°F ~ 149°F)
	Ambient Humidity		Below 90 % RH Max. (Non-Condensing)
	Altitude-Vibration		Below 1,000m (From 1000 to 4000m, the rated input voltage and rated output current of the drive must be derated by 1% for every 100m.), Below 5.9m/sec ² (0.6g)
	Application Site		Pollution degree 2, No Corrosive Gas, Combustible Gas, Oil Mist, or Dust

(1) Rated capacity ($\sqrt{3} \times V \times I$) is based on 220V for 200V class and 460V for 400V class.
 (3) IP20 or UL Enclosed Type1 can be provided by the option.
 (5) Overload rating 120%, 1 min is based on ambient 25°C

(2) Indicates the maximum applicable capacity when using a 4-Pole standard motor.
 (4) IP20 or UL Enclosed Type1 is not provided.

Standard Specifications

Common Specifications (External)

Keypad	LCD	32 character display keypad Download and Upload available	All units
Remote	Remote cable	2m, 3m and 5m long keypad cable enables users to control the drive from a distant area	Optional
Dynamic braking	DB resistor	To enhance the regenerative braking performance, it makes the drive to accelerate/decelerate rapidly	According to drive capacity
	DB unit	If it need a regenerative braking, it is used with DB resistor	
Conduit option	Conduit for NEMA TYPE 1	Install it to fit for NEMA TYPE 1 Enclosure or IP20	15~90kW (20~125HP)
Communication option card	DEVICENET	DEVICENET optional communication card	All series (Above S/W V10)
	PROFIBUS	PROFIBUS optional communication card	All series (Above S/W V10)
	LS485/MODBUS_RTU	LS485/MODBUS_RTU optional communication card	All series (Above S/W V10)
	LonWorks	Lonworks optional communication card	All series (Above S/W V10)
	BACNet	BACNet optional communication card	All series (Above S/W V10)
	MODBUS_TCP	MODBUS_TCP optional communication card	All series (Above S/W V10)
	Metasys_N2	Metasys_N2 optional communication card	All series (Above S/W V10)
	CCLink	CCLink optional communication card	All series (Above S/W V10)
	CANopen	CANopen optional communication card	All series (Above S/W V10)

Wiring

■ For 0.75~30kW (1~40HP)

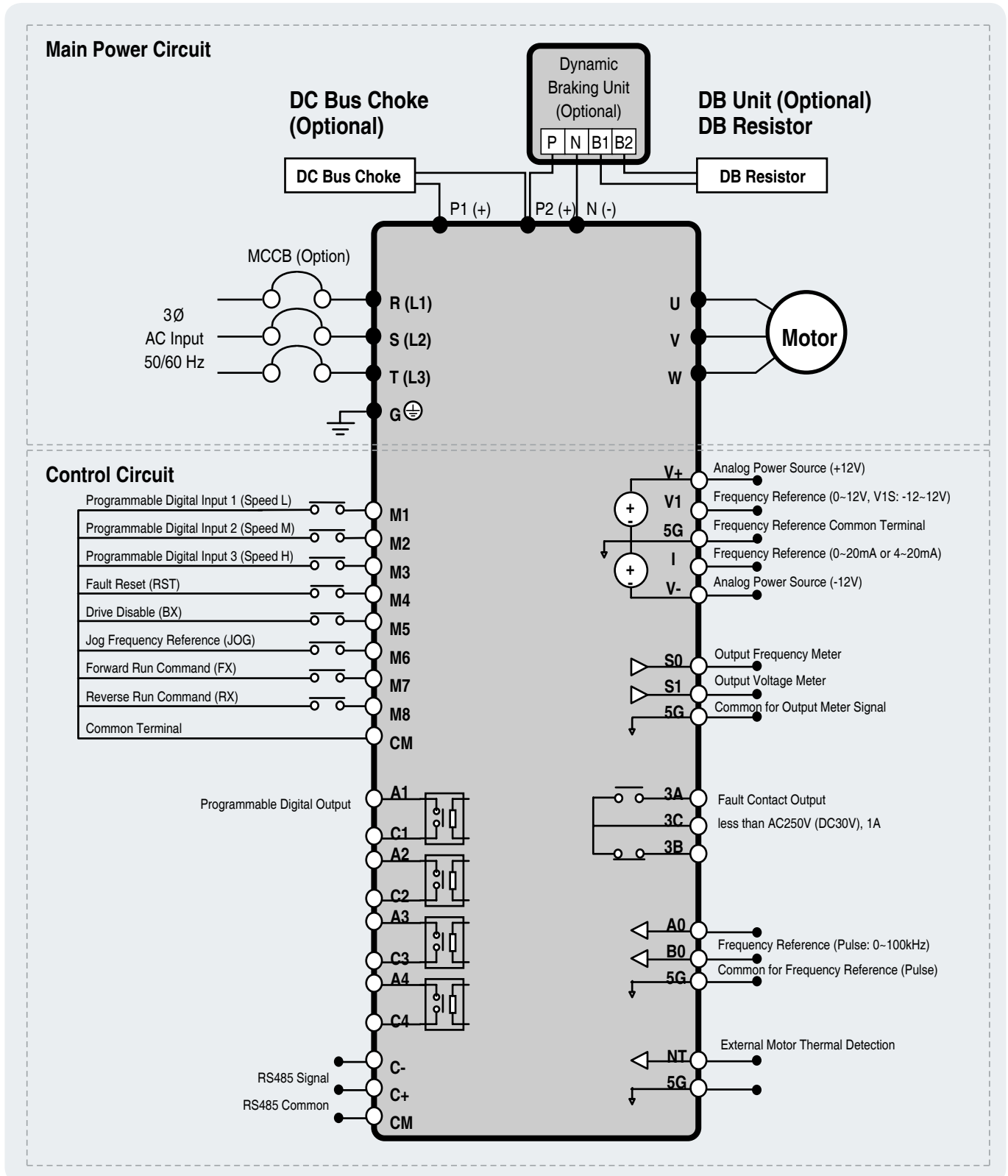

- Note 1) 5G is Common Ground for Analog Input / Output. (Only applied to 0.75 - 30kW products)
- 2) Use terminal V1 for V1, V1S (0~12V, -12~-12V) input.
- 3) To add DC reactor, Remove DC Bus Choke and connect to P1(+), P2(+).
- 4) SA, SB terminal is provided with 600V class model only.

■ For 37~90kW (50~125HP) / 315~450kW (400~600HP)

Main Power Circuit

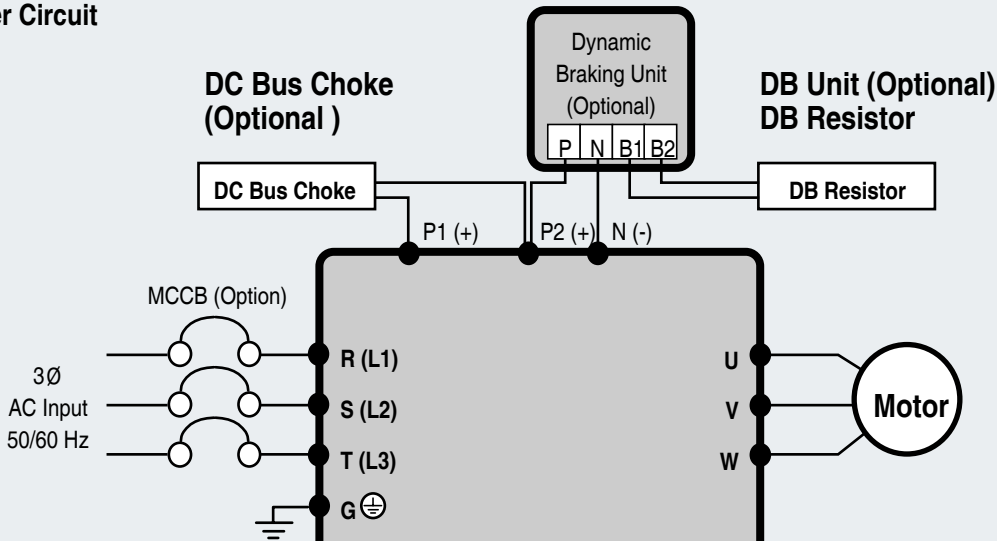

Control Circuit

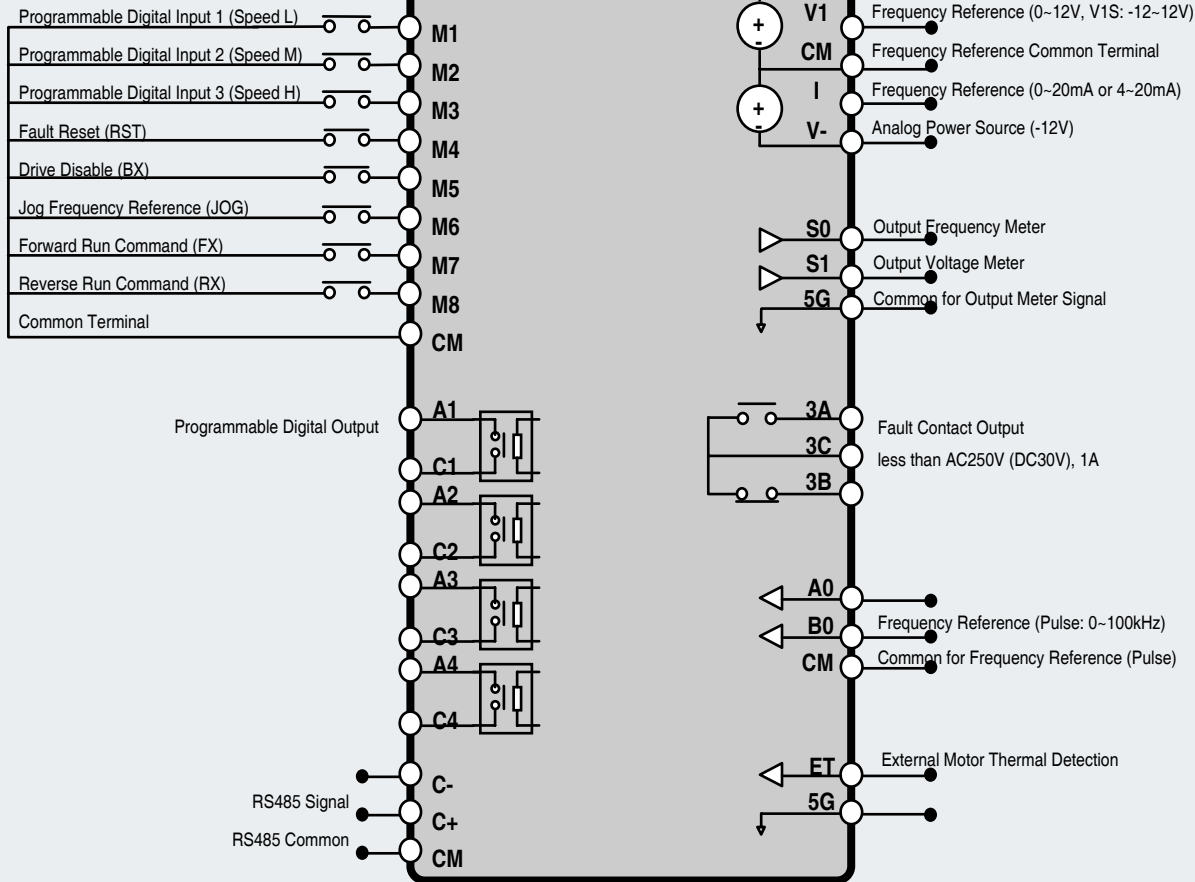

- Note 1) 5G is Common Ground for Analog Meter Output (S0, S1) and External motor thermal detection (ET). CM is Common Ground for Analog input.
- 2) Use terminal V1 for V1, V1S (0~12V, -12~-12V) input.
- 3) To add DC reactor, remove DC Bus Choke and connect to P1(+), P2(+).
- 4) SA, SB terminal is provided with 600V class model only.

■ For 110~280kW (150~350HP)

Main Power Circuit

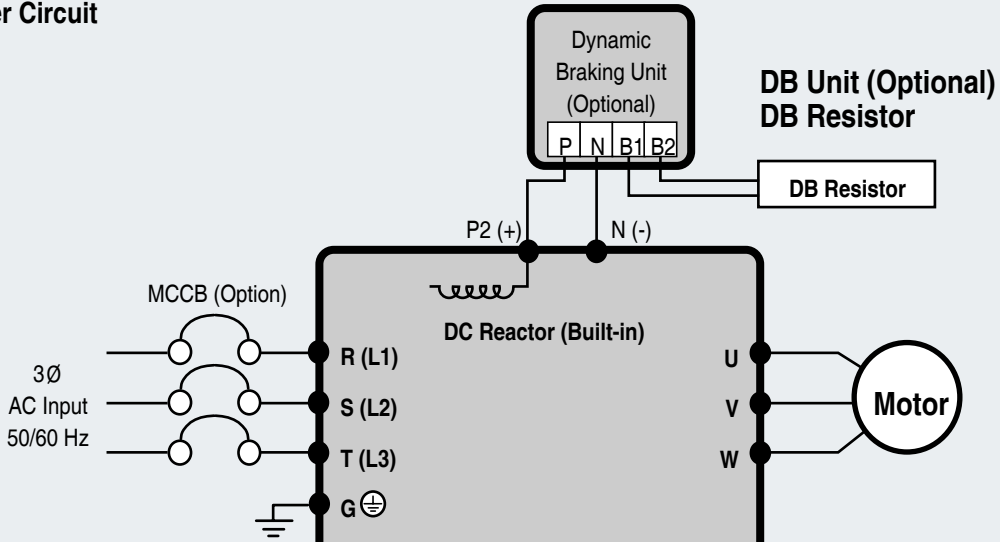

Control Circuit

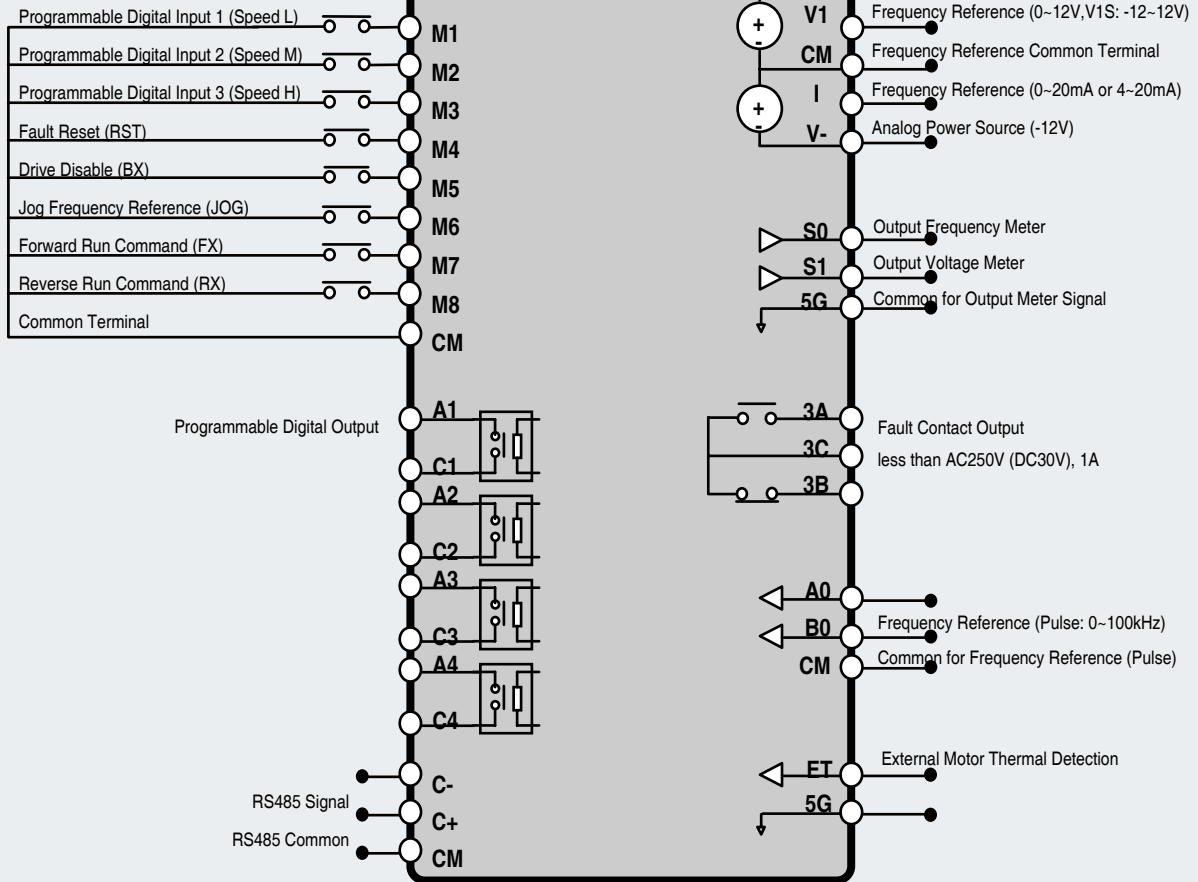

- Note 1) 5G is Common Ground for Analog Meter Output (S0, S1) and External motor thermal detection (ET). CM is Common Ground for Analog input.
- 2) Use terminal V1 for V1, V1S (0~12V, -12~12V) input.
- 3) DC Reactor is built basically in the inverters for 110~280kW(150~350HP)
- 4) SA, SB terminal is provided with 600V class model only.

iP5A

Wiring

■ For 15~30kW (20~40HP) Built-in DCL Type

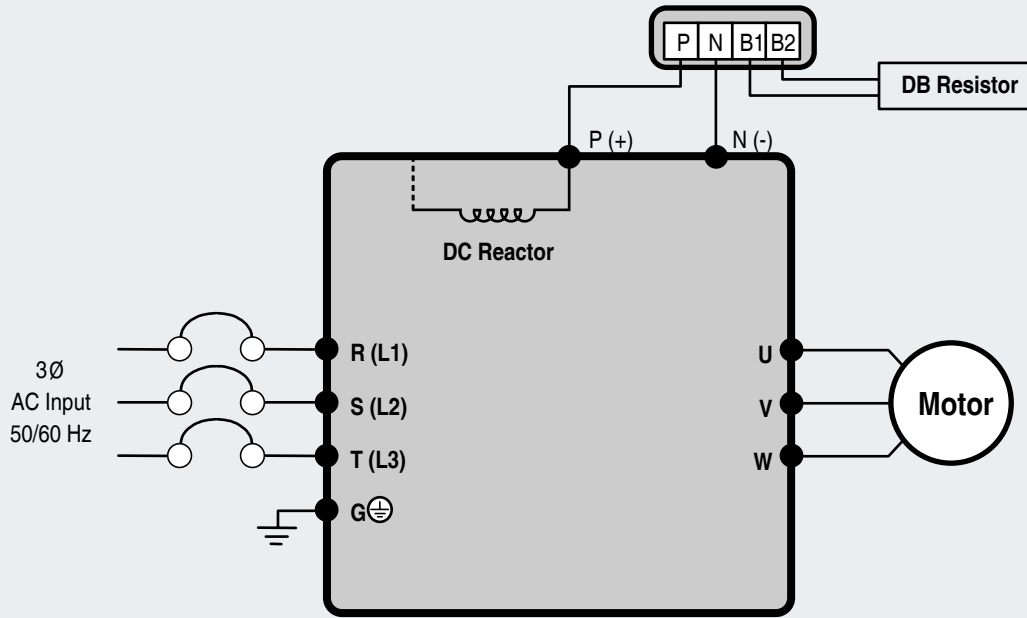

■ For 37~90kW (50~125HP) Built-in DCL Type

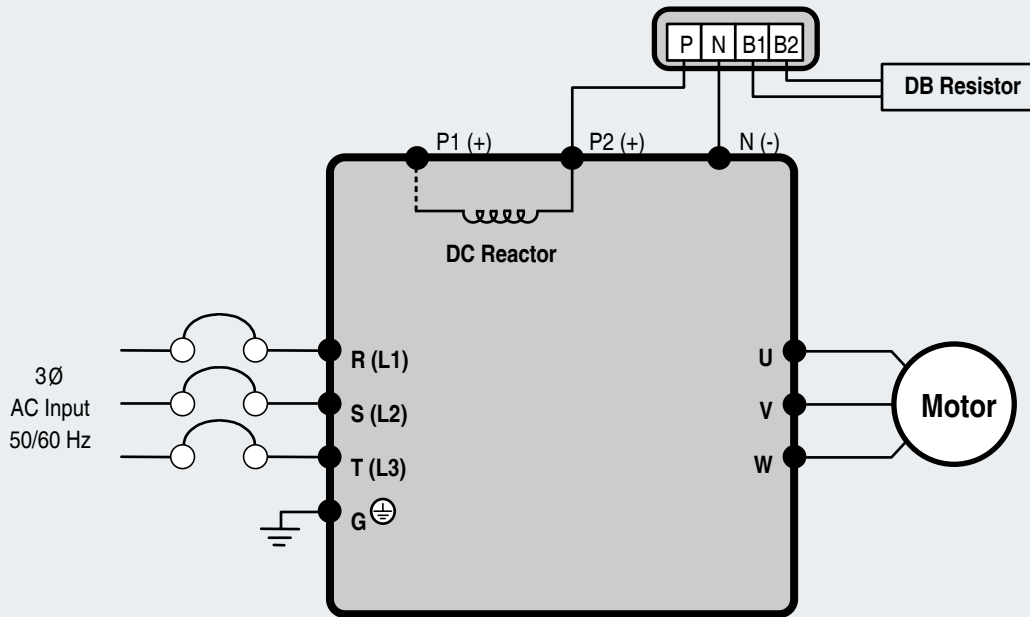

Note) P1 (+) is not provided for wiring.

Terminal Configurations (Power Circuit Terminal)

■ 0.75~30kW (1~40HP) <200V/400V/600V Class>

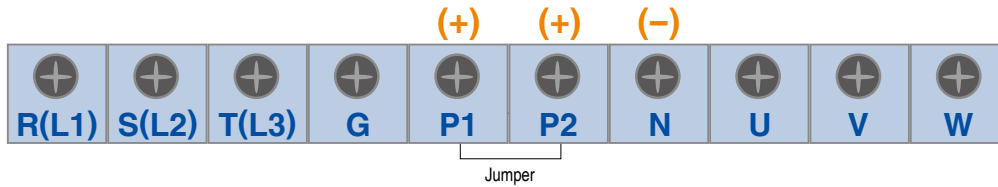

■ 37~90kW (50~125HP) / 315~450kW (400~600HP) <400V/600V Class>

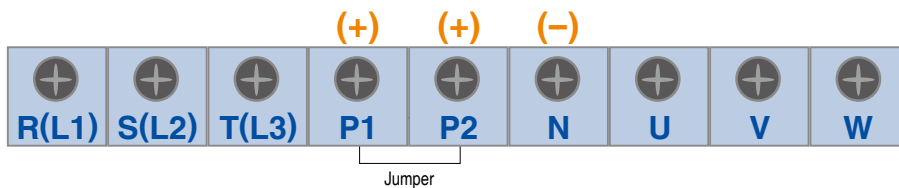

■ 15~18.5kW (20~25HP) <Built-in DC Reactor Type, 400V Class>

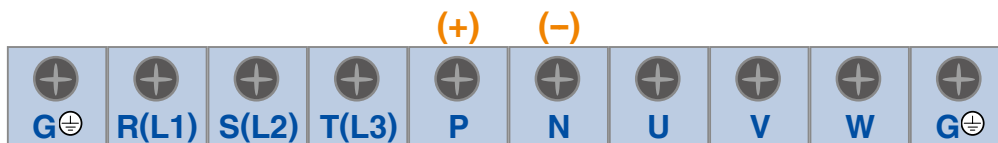

■ 22~30kW (30~40HP) <Built-in DC Reactor Type, 400V Class>

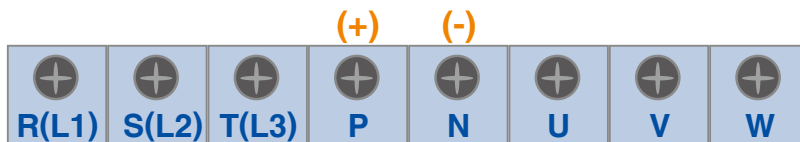

■ 37~90kW (50~125HP) / 110 ~280kW (150~350HP) <Built-in DC Reactor Type, 400V Class>

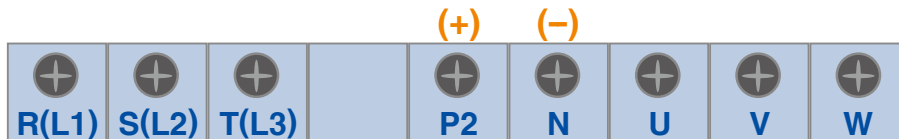

Note) P1 (+) is not provided for wiring.

Symbol	Description
R, S, T (L1, L2, L3)	AC Line Voltage Input
G	Earth Ground
P1 (+), P2 (+)	External DC Reactor [P1 (+)-P2 (+)] Connection Terminals (Jumper must be removed).
P2 (+), N (-) or P (+), N (-)	DB Unit [P2 (+)-N (-)] Connection Terminals
U, V, W	3 Phase Power Output Terminals to Motor

iP5A

Terminal Configurations (Power Circuit Terminal)

■ Grounding

Drive Capacity		Grounding wire Sizes, AWG or kcmil (mm ²)		
kW	HP	200V Class	400V Class	600V Class
5.5 ~ 7.5	7.5 ~ 10	10 (5.5)	12 (3.5)	14 (2.5)
11 ~ 15	15 ~ 20	6 (14)	8 (8)	12 (3.5)
18.5 ~ 30	25 ~ 40	4 (22)	6 (14)	8 (8)
37 ~ 55	50 ~ 75	-	4 (22)	6 (14)
75 ~ 90	100 ~ 125	-	2 (38)	4 (22)
110 ~ 132	150 ~ 200	-	1/0 (60)	2 (38)
160 ~ 280	250 ~ 350	-	4/0 (100)	
315 ~ 375	400 ~ 600	-	300 (150)	
450	700	-	400 (200)	

■ Wires & Terminal lugs

Refer to below for wires, terminal lugs, and screws used to connect the drive power input and output.

Drive capacity	Terminal screw size	Screw torque		Wire size				
				R(L1), S(L2), T(L3)		U, V, W		
		Kgf · cm	lb · in	mm ²	AWG or kcmil	mm ²	AWG or kcmil	
200V Class	0.75kW(1HP)	M4	7.1 ~12.2	6.2 ~10.6	2.5	14	2.5	14
	1.5kW(2HP)	M4	7.1 ~12.2	6.2 ~10.6	2.5	14	2.5	14
	2.2kW(3HP)	M4	7.1 ~12.2	6.2 ~10.6	2.5	14	2.5	14
	3.7kW(5HP)	M4	7.1 ~12.2	6.2 ~10.6	4	12	4	12
	5.5kW(7.5HP)	M4	7.1 ~12.2	6.2~10.6	5.5	10	5.5	10
	7.5kW(10HP)	M5	24.5 ~31.8	21.2~27.6	8	8	8	8
	11kW(15HP)	M5			14	6	14	6
	15kW(20HP)	M6	30.6 ~38.2	26.6~33.2	22	4	22	4
	18.5kW(25HP)	M6			38	2	38	2
	22kW(30HP)	M8	61.2 ~91.8	53.1~79.7	38	2	38	2
30kW(40HP)	M8	60			1/0	60	1/0	
400V Class	0.75kW(1HP)	M4	7.1 ~12.2	6.2 ~10.6	2.5	14	2.5	14
	1.5kW(2HP)	M4	7.1 ~12.2	6.2 ~10.6	2.5	14	2.5	14
	2.2kW(3HP)	M4	7.1 ~12.2	6.2 ~10.6	2.5	14	2.5	14
	3.7kW(5HP)	M4	7.1 ~12.2	6.2 ~10.6	2.5	14	2.5	14
	5.5kW(7.5HP)	M4	7.1 ~12.2	6.2~10.6	3.5	12	3.5	12
	7.5KW(10HP)	M4			3.5	12	3.5	12
	11 kW(15HP)	M4	30.6~38.2	26.6~33.2	5.5	10	5.5	10
	15 kW(20HP)	M6			8	8	8	8
	18.5kW(25HP)	M6	61.2~91.8	53.1~79.7	14	6	14	6
	22~30kW(30~40HP)	M8			22	4	22	4
	37~55kW(50~75HP)	M8	89.7~122.0	77.9~105.9	38	2	38	2
	75~90kW(100~125HP)	M10			60	1/0	60	1/0
	110~132kW(150~200HP)	M12	182.4~215.0	158.3~186.6	100	4/0	100	4/0
	160kW(250HP)	M12			150	300	150	300
	220kW(300HP)	M12			200	400	200	400
	280kW(350HP)	M12			250	500	250	500
315kW(400HP)	M12	325			700	325	700	
375kW(500HP)	M12	2×200			2×400	2×200	2×400	
450kW(600HP)	M12	2×250			2×500	2×250	2×500	
5.5kW(7.5HP)	M4	7.1 ~12.2			6.2~10.6	3.5	12	3.5
7.5KW(10HP)	M4		3.5	12		3.5	12	
11 kW(15HP)	M4	30.6~38.2	26.6~33.2	5.5	10	5.5	10	
15 kW(20HP)	M6			8	8	8	8	
18.5kW(25HP)	M6	61.2~91.8	53.1~79.7	14	6	14	6	
22~30kW(30~40HP)	M8			22	4	22	4	
37~55kW(50~75HP)	M8	89.7~122.0	77.9~105.9	38	2	38	2	
75~90kW(100~125HP)	M10			60	1/0	60	1/0	
110~132kW(150~200HP)	M12	182.4~215.0	158.3~186.6	100	4/0	100	4/0	

* Apply the rated torque to terminal screws. * Loose screws can cause of short circuit or malfunction. Tightening the screw too much can damage the terminals and cause a short circuit or malfunction.
 * Use copper wires only with 600V, 75°C ratings. For 7.5~11kW 240V type drives, R(L1), S(L2), T(L3) and U, V, W terminals are only for use with insulated ring type connector.

Terminal Configurations (Control Circuit Terminal)

■ 0.75~30kW / 1~40HP (200V/400V Class)

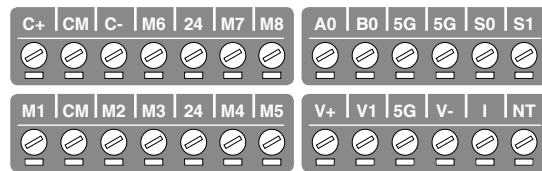
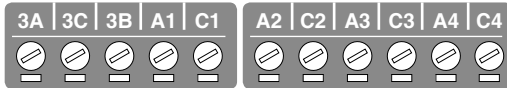
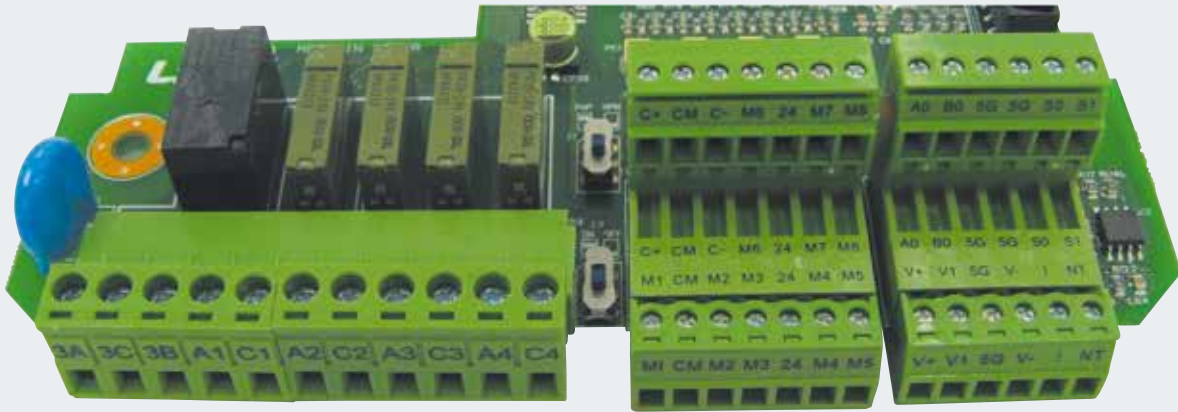

■ 37~450 kW/50~600HP (400V Class)

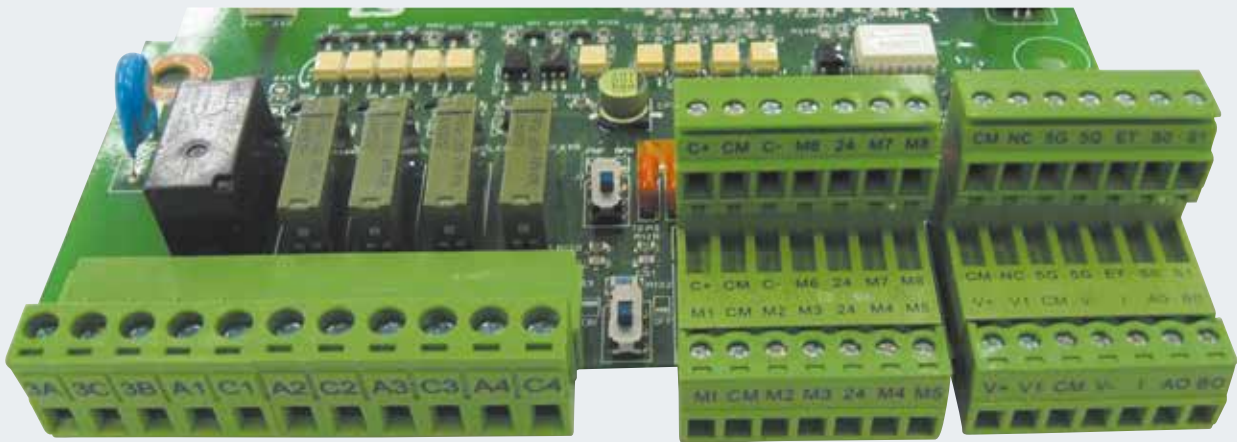

Terminal Configurations (Control Circuit Terminal)

Type	Symbol	Name	Description
Input Signal	Starting Contact Function Select	M1, M2, M3	Programmable Digital Input 1, 2, 3 Defines programmable digital inputs (Factory setting : Multi-step frequency 1,2,3)
		FX [M7]	Forward Run Command Forward run when closed and stopped when open
		RX [M8]	Reverse Run Command Reverse run when closed and stopped when open
		JOG [M6]	Jog Frequency Reference Runs at jog frequency when the jog signal is on. The direction is set by the FX (or RX) signal
		BX [M5]	Emergency Stop When the BX signal is ON, the output of the drive is turned off. When motor uses an electrical brake to stop, BX is used to turned off the output signal. Take caution when BX signal is off (Not turned off by latching) and FX signal (or RX signal) is on. Under these conditions, the motor will run!
		RST [M4]	Fault Reset Used for fault reset.
		CM	Sequence Common (NPN) Common terminal for NPN contact
		24	Sequence Common (PNP) Common 24V terminal for PNP contact input. Maximum output : +24V, 100mA
	Analog Frequency Setting	V+, V-	Analog Power Source (+12V,-12V) Power supply for analog frequency setting. Maximum output : +12V, 100mA, -12V, 100mA
		V1	Frequency Reference (Voltage) Used by a DC 0~12V or -12~12V input to set the frequency reference. (Input impedance is 20kΩ)
		I	Frequency Reference (Current) Used by a 0-20mA input to set the frequency reference. (Input impedance is 249Ω)
		A0, B0	Frequency Reference (Pulse) Used by a pulse input to set the frequency reference.
		5G (~30kW) CM (37kW~)	Frequency Reference Common Terminal Common terminal for analog frequency reference signal
	External Motor Thermal Detection	NT (~30kW) ET (37kW~)	External Motor Thermal Detection Motor thermal sensor input. Used to prevent motor from overheating by using a NTC or PTC thermal sensor.
5G		Common for NT (or ET) Common terminal for external motor thermal detection	
Built-in RS485 Terminal	C+, C-	RS485 signal High, Low RS485 signal (See RS485 communication in manual for more details.)	
	CM	RS485 common Common ground. Terminal for RS485 interface.	
Output Signal	Analog Output	S0, S1,	Programmable Voltage Output Voltage output for one of the following : Output frequency, output current, output voltage, DC link voltage. Default is set to output frequency. (Maximum output voltage and output current are 0-12V and 1mA)
		5G	Analog Common Terminal Common terminal for analog output (S0, S1)
	Contact	3A, 3C, 3B	Fault Contact Output Energizes when a fault is present. (AC250V, 1A; DC30V, 1A) Fault : 3A-3C closed (3B-3C open) Normal : 3B-3C Closed (3A-3C open)
		A1~4, C1~4	Programmable Digital Output Defined by programmable digital output terminal settings (AC250V, 1A or less; DC30V, 1A or less)

Note) NC terminal is unavailable

iP5A provides Sink/Source (NPN/PNP) modes for sequence input terminal on the control circuit. The logic of the input terminal is settable to Sink mode (NPN mode)/Source mode (NPN mode) by using the J1 switch. Connection method is shown below.

Sink mode (NPN mode)

- Put J1 switch down to set to Sink mode (NPN mode). CM terminal (24V GND) is common terminal for contact signal input.
- The factory default is Sink mode (NPN mode).

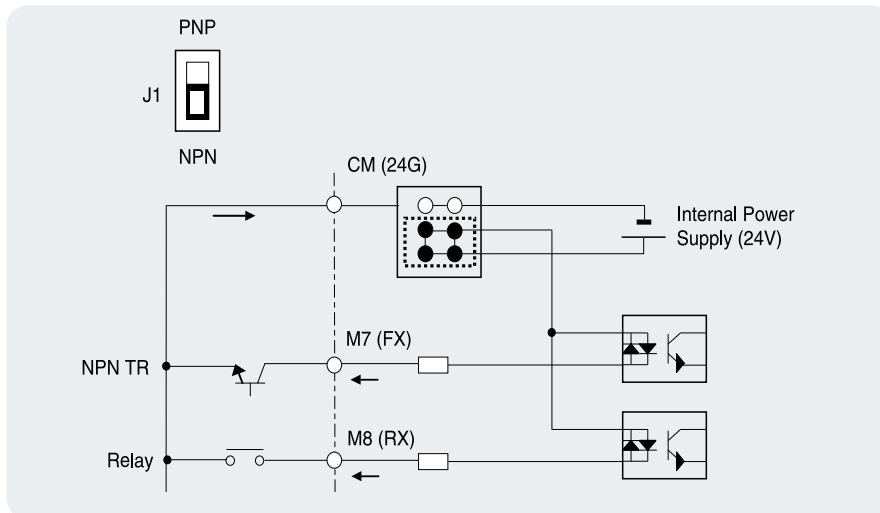

**Source mode (PNP mode)
Internal Power Supply Used**

- Put J1 switch up to set to Source mode (PNP mode). Terminal 24 (24V Power Supply) is common terminal for contact input signal.

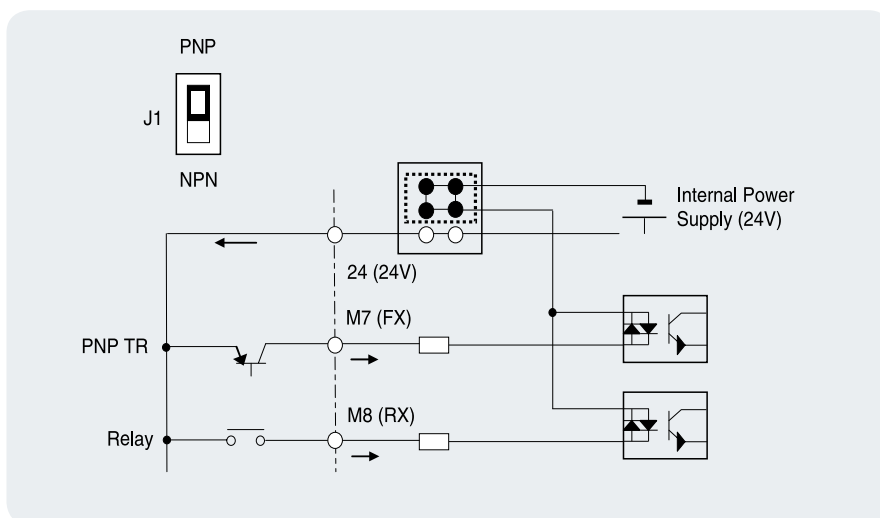

**Source mode (PNP mode)
External Power Supply Used**

- Put J1 switch up to set to Source mode (PNP mode).
- To use external 24V Power Supply, make a sequence between external Power Supply (-) terminal and CM (24V GND) terminal.

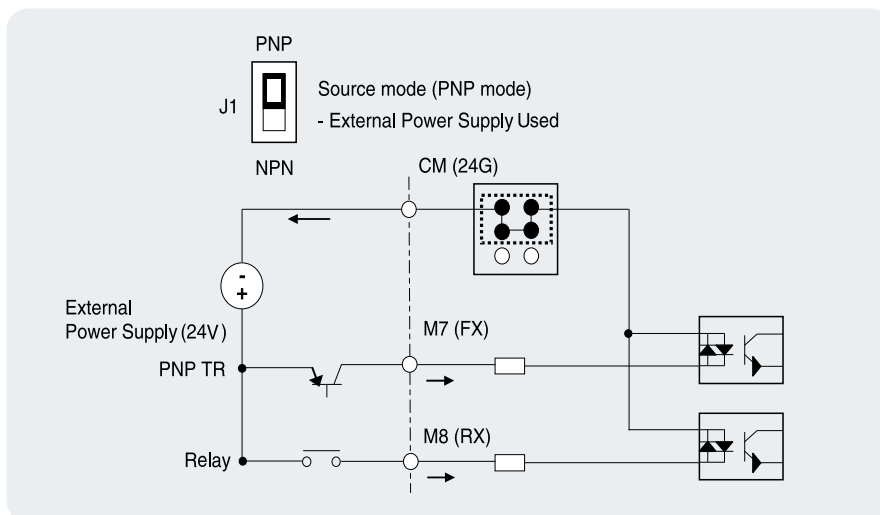

iP5A

Programming Keypad

■ LCD Loader

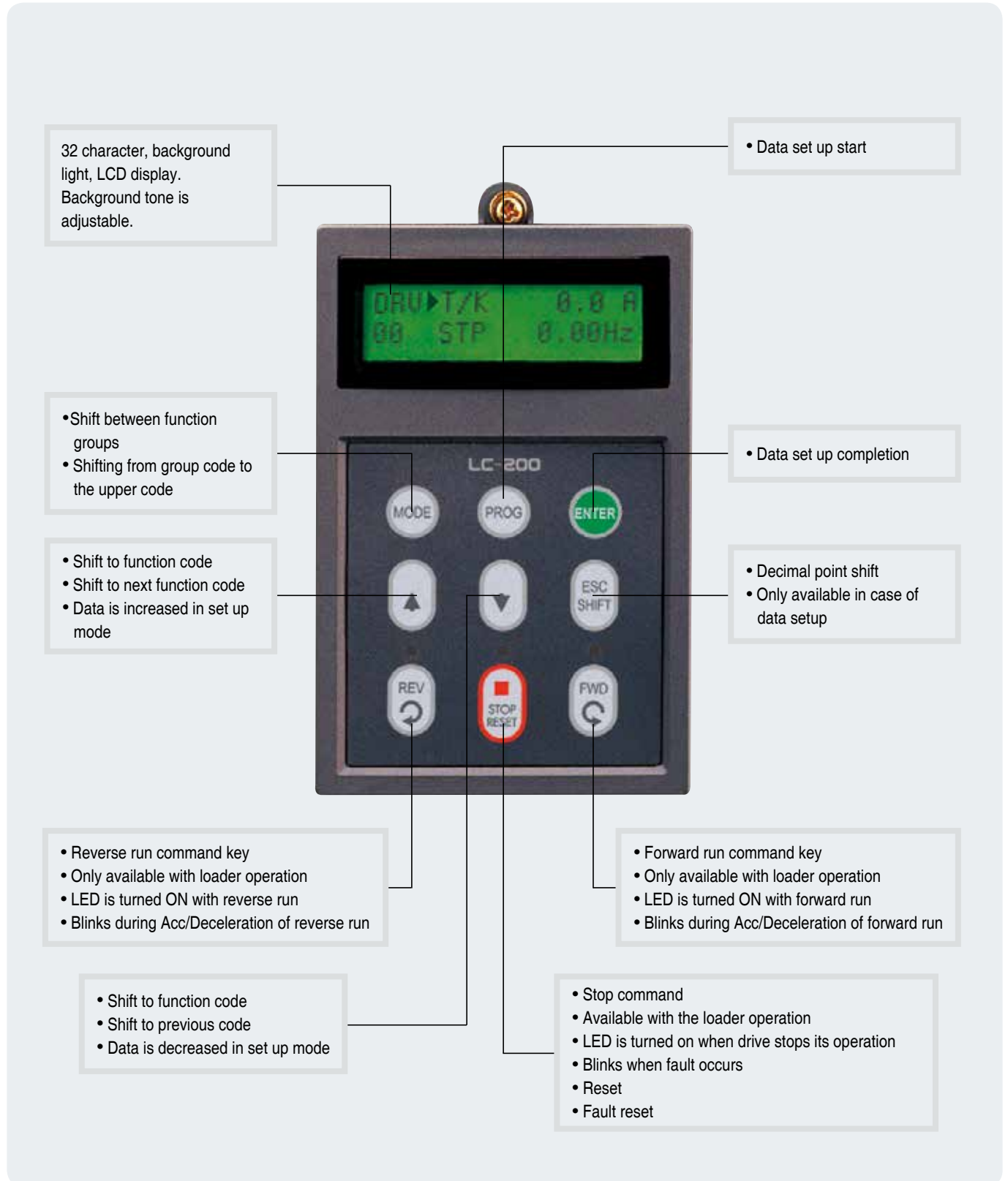

Programming Keypad (Parameter Navigation)

■ Parameter group moves directly to DRV group by pressing [SHIFT] key in any parameter code.

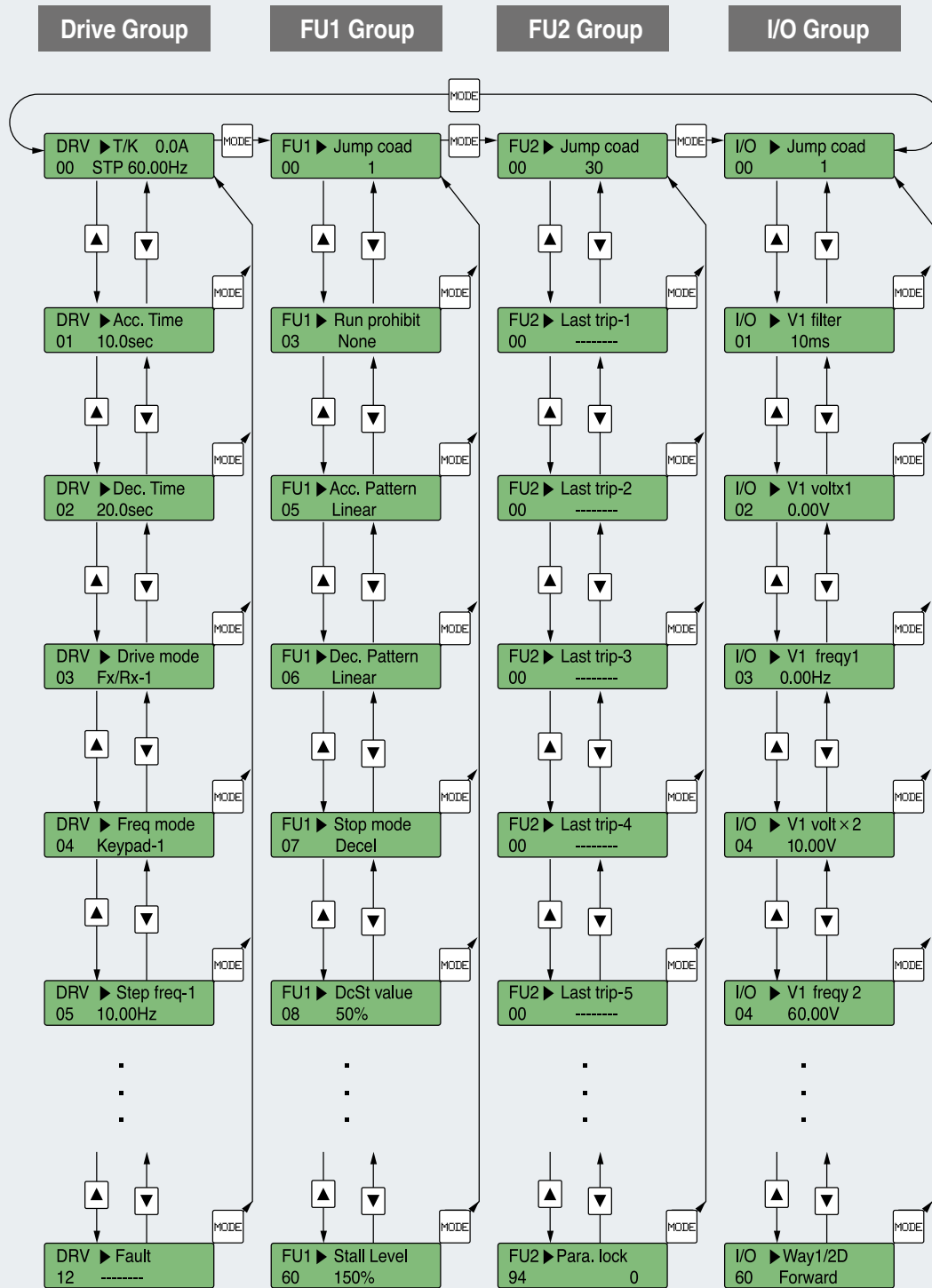

iP5A

Parameter Description

DRV Group

CODE	Comm. Addr	Description	LCD Keypad Display	Setting Range	Factory Default	Adj. During Run
DRV-00 <small>Note1</small>	9100	Command Frequency (Output Frequency during motor run, Reference Frequency during motor stop), Output Current (LCD)	Cmd. freq	0 to FU1-30[Hz]	0 [Hz]	○
DRV-01	9101	Acceleration Time	Acc. Time	0 to 6000 [sec]	20 [sec] 60 [sec]	○
DRV-02	9102	Deceleration Time	Dec. time	0 to 6000 [sec]	30 [sec] 90 [sec]	○
DRV-03	9103	Drive Mode (Run/Stop Method)	Drive mode	0 (Keypad)	1 (Fx/Rx-1)	×
				1 (Fx/Rx-1)		
				2 (Fx/Rx-2)		
				3 (Int. 485)		
DRV-04	9104	Frequency Mode (Frequency setting method)	Freq mode	0 (Keypad-1)	0 (Keypad-1)	×
				1 (Keypad-2)		
				2 (V1)		
				3 (V1S)		
				4 (I)		
				5 (V1+I)		
				6 (Pulse)		
				7 (Int. 485)		
				8 (Ext. PID)		
DRV-05	9105	Step Frequency 1	Step freq-1	0 to FU1-30[Hz]	10 [Hz]	○
DRV-06	9106	Step Frequency 2	Step freq-2		20 [Hz]	○
DRV-07	9107	Step Frequency 3	Step freq-3		30 [Hz]	○
DRV-08	9108	Output Current	Current	* [A]	* [A]	*
DRV-09	9109	Motor Speed	Speed	* [rpm]	* [rpm]	*
DRV-10	910A	DC link Voltage	DC link Vtg	* [V]	* [V]	*
DRV-11	910B	User Display Selection	User disp		Output voltage [V]	*
DRV-12	910C	Current Trip Display	Fault	*	*	*
DRV-14 <small>Note2</small>	910E	Target/Output Frequency Display	Tar. Out. Freq.	* [Hz]	* [Hz]	*
DRV-15 <small>Note2</small>	910F	Reference/Feedback Frequency Display	Ref. Fbk. Freq.	* [Hz]	* [Hz]	*
DRV-16	9110	Speed Unit Selection	Hz/Rpm Disp	Hz or Rpm	Hz	○
DRV-18 <small>Note2</small>	9112	PID Parameter	R T F O	* [Hz]	* [Hz]	×
DRV-19	9113	AD Parameter	V1 V2 V1S I	*	*	×
DRV-20 <small>Note3</small>	9114	EXT-PID Parameter	R T F O	%	%	×
DRV-22	9116	Local/Remote Key	LocalRemKey	1 (Cntl&RefStop)	Cntl&RefStop	○
				2 (Control Stop)		
				3 (Ref Only)		
				4 (Cntl&Ref Run)		
				5 (Control Run)		
				6 (Disable)		
DRV-23	9117	Keypad Mode Key	Ref Mode	1 (Minimum Spd)	Disable	○
				2 (Last Spd)		
				3 (Preset Spd 1)		
				4 (Stop)		
				5 (Fault)		
				6 (Disable)		
DRV-91 <small>Note4</small>	915B	Drive mode 2	Drive mode2	0 (Keypad)	1 (Fx/Rx-1)	×
				1 (Fx/Rx-1)		
				2 (Fx/Rx-2)		
DRV-92	915C	Frequency mode 2	Freq mode2	0 (Keypad-1)	0 (Keypad-1)	×
				1 (Keypad-2)		
				2 (V1)		
				3 (V1S)		
				4 (I)		
				5 (V1+I)		
6 (Pulse)						

The gray-highlighted codes are hidden parameters and will appear when the related functions are to be set.

Note 1 The speed unit is changed from [Hz] to [%] when DRV-16 is set to [Rpm]. Only User Unit will be displayed when APP-02 is set to [Yes] and when APP-06 is set to either I, V1 or Pulse and when one of I/O-86- I/O-88 is set to either [Speed] (Hz or Rpm), [Percent], [Bar], [mBar], [kPa] or [Pa]. **Output Frequency (Hz or Rpm; Unit of output speed) is displayed in DRV-00 during the Drive is running. User Unit reference (Unit of PID controller selected) is displayed in DRV-00 during the Drive is not running.** **2** DRV-15, DRV-18 will appear when APP-02 [Process PI Mode] is set to Yes. Also User Unit is displayed when one of I/O-86- I/O-88 is set to either [Speed][Hz or Rpm], [Percent], [Bar], [mBar], [kPa] or [Pa]. **3** DRV-20 will appear when APP-80 [ExtProcess PI Mode] is set to Yes. **4** DRV-91/92 will appear only when DRV-22 is set to [2nd Source].

FU1 GROUP

CODE	Comm. Addr	Description	LCD Keypad Display	Setting Range	Factory Default	Adj. During Run
FU1-00	9200	Jump to Desired Code #	Jump code	1 to 74 (Use Only LCD Keypad)	1	○
FU1-01	9201	Run Prevention	Run prevent	0 (None)	0 (None)	×
				1 (Fwd prev)		
				2 (Rev prev)		
FU1-02	9202	Acceleration Pattern	Acc. Pattern	0 (Linear)	0 (Linear)	×
				1 (S-curve)		
				2 (U-curve)		
FU1-03	9203	Deceleration Pattern	Dec. Pattern	0 (Linear)	0 (Linear)	×
				1 (S-curve)		
				2 (U-curve)		
FU1-04 <small>Note5)</small>	9204	Start Curve for S-Curve Accel/Decel Pattern	Start Curve	0 to 100[%]	50 [%]	×
FU1-05	9205	End Curve for S-Curve Accel/Decel Pattern	End Curve	0 to 100[%]	50 [%]	×
FU1-10	920A	Pre-Heat	Pre-Heat mode	0 (No)	0 (No)	×
				1 (Yes)		
FU1-11	920B	Pre-Heat Value	Pre Heat level	1 to 50[%]	30 (%)	×
FU1-12	920C	Pre-Heat Duty	Pre Heat Perc	1 to 100 [%]	50 (%)	×
FU1-20	9214	Start Mode	Start mode	0 (Accel)	0 (Accel)	×
				1 (Dc-start)		
				2 (Flying-start)		
FU1-21 <small>Note6)</small>	9215	Starting DC Injection Braking Time	DcSt time	0 to 60 [sec]	0.1 [sec]	×
FU1-22	9216	Starting DC Injection Braking Value	DcSt value	0 to 150 [%]	50 [%]	×
FU1-23	9217	Stop Mode	Stop mode	0 (Decel)	0 (Decel)	×
				1 (Dc-brake)		
				2 (Free-run)		
				3 (Flux-brake)		
FU1-24 <small>Note7)</small>	9218	DC Injection Braking On-delay Time	DcBlk Time	0.1 to 60 [sec]	0.1 [sec]	×
FU1-25	9219	DC Injection Braking Frequency	DcBrk freq	0.1 to 60 [Hz]	5 [Hz]	×
FU1-26	921A	DC Injection Braking Time	DcBr time	0 to 60 [sec]	1 [sec]	×
FU1-27	921B	DC Injection Braking Value	DcBr value	0 to 200 [%]	50 [%]	×
FU1-28	921C	Safety Stop	Safety Stop	0 (No)	0 (No)	×
				1 (Yes)		
FU1-29	921D	Power Source Freq	Line Freq	40 to 120 [Hz]	60.00 [Hz]	×
FU1-30	921F	Maximum Frequency	Max Freq	40 to 120 [Hz]	60.00 [Hz]	×
FU1-31	9220	Base Frequency	Base Freq	30 to 120 [Hz]	60.00 [Hz]	×
FU1-32	9220	Starting Frequency	Start Freq	0.01 to 10 [Hz]	0.50 [Hz]	×
FU1-33	9221	Frequency Limit selection	Freq limit	0 (No)	0 (No)	×
				1 (Yes)		
FU1-34 <small>Note8)</small>	9222	Freq Lower Limit	Lim Lo Freq	0 - FU1-35	0.50 [Hz]	○
FU1-35	9223	Freq Upper Limit	Lim Hi Freq FU	1-34 - FU1-30	60.00 [Hz]	×
FU1-40	9228	Volts/Hz Pattern	V/F Pattern	0 (Linear)	0 (Linear)	×
				1 (Square)		
				2 (User V/F)		

Parameter Description

FU1 GROUP

CODE	Comm. Addr	Description	LCD Keypad Display	Setting Range	Factory Default	Adj. During Run	
FU1-41 <small>Note9)</small>	9229	User V/F – Frequency 1	User freq 1	0 to FU1-30	15.00 [Hz]	×	
FU1-42	922A	User V/F – Voltage 1	User volt 1	0 to 100 [%]	25 [%]	×	
FU1-43	922B	User V/F – Frequency 2	User freq 2	0 to FU1-30	30.00 [Hz]	×	
FU1-44	922C	User V/F – Voltage 2	User volt 2	0 to 100 [%]	50 [%]	×	
FU1-45	922D	User V/F – Frequency 3	User freq 3	0 to FU1-30	45.00 [Hz]	×	
FU1-46	922E	User V/F – Voltage 3	User volt 3	0 to 100 [%]	75 [%]	×	
FU1-47	922F	User V/F – Frequency 4	User freq 4	0 to FU1-30	60.00 [Hz]	×	
FU1-48	9230	User V/F – Voltage 4	User volt 4	0 to 100 [%] 1	00[%]	×	
FU1-49	9231	Input voltage adjustment	VAC 380.0V	73 to 115.0 [%]	86.4 [%]	×	
FU1-50	9232	Motor Rated Voltage	Motor Volt	0 to 600 [V]	380 [V]	×	
FU1-51	9233	Energy Save	Energy save	0	(None)	0 (None)	×
				1	(Manual)		
				2	(Auto)		
FU1-52 <small>Note10)</small>	9234	Energy Save %	Manual save%	0 to 30 [%]	0 [%]	○	
FU1-54	9236	Integrating Wattmeter	KiloWattHour	M kWh	*	×	
FU1-55	9237	Drive Temperature	Inv. Temp.	0 to 160 [degree]	*	×	
FU1-56	9238	Motor Temperature	Motor Temp.	0 to 160 [degree]	*	×	
FU1-57	9239	No Motor Selection	No Motor Sel	0	(No)	0 (No)	×
				1	(Yes)		
FU1-58	923A	Trip Current Level	No Motor Level	5 to 100 [%]	5 [%]	×	
FU1-59	923B	Trip Time Setting	No Motor Time	0.5 to 10.0 [sec]	3.0 [sec]	×	
FU1-60	923C	Electronic Thermal Selection	ETH select	0	(No)	1 (Yes)	○
				1	(Yes)		
FU1-61	923D	Electronic Thermal Level for 1 Minute	ETH 1min	FU1-62 to 200 [%]	150 [%]	○	
FU1-62	923E	Electronic Thermal Level for Continuous	ETH Cont	50 to FU1-61(Maximum 150%)	120 [%]	○	
FU1-63	923F	Characteristic Selection (Motor Type)	Motor type	0	(Self-cool)	0 (Self-cool)	○
				1	(Forced-cool)		
FU1-64	9240	Overload Warning Level	OL level	30 to 110 [%]	110 [%]	○	
FU1-65	9241	Overload Warning Time	OL time	0 to 30 [sec]	10 [sec]	○	
FU1-66	9242	Overload Trip Selection	OLT select	0	(No)	0 (No)	○
				1	(Yes)		
FU1-67 <small>Note11)</small>	9243	Overload Trip Level	OLT level	30 to 150 [%]	120[%]	○	
FU1-68	9244	Overload Trip Delay Time	OLT time	0 to 60 [sec]	60 [sec]	○	
FU1-69	9245	Input/Output Phase Loss Protection	Trip select	000 to 111 (Bit Set)	100	○	
FU1-70	9246	Stall Prevention Selection	Stall Mode.	No/Yes	No	×	
FU1-71	9247	Stall Prevention Level	Stall level	30 to 200 [%]	120[%]	○	
FU1-72	9248	Accel/Decel Change Frequency	Acc/Dec ch F	0 to FU1-30	0 [Hz]	×	
FU1-73	9249	Reference Frequency for Accel and Decel	Acc/Dec freq	0	(Max freq)	0 (Max freq)	×
				1	(Delta freq)		
FU1-74	924A	Accel/Decel Time Scale	Time scale	0	(0.01 sec)	1 (0.1 sec)	○
				1	(0.1 sec)		
				2	(1 sec)		
FU1-75	924B	Up Down Save Mode	UpDnSaveMode	0	(No)	0 (No)	×
				1	(Yes)		
FU1-76 <small>Note31)</small>	924C	Up Down Save Freq	UpDnSaveFreq	0 to 120[Hz]	0.00Hz	○	

□ The gray-highlighted codes are hidden parameters and will appear when the related functions are to be set.

Note 9) FU1-41~48 only displayed when FU1-40 is set to 'User V/F'.

10) Only displayed when FU1-51 is set to 'Manual'.

11) Only displayed when FU1-66 is set to 'Yes'.

31) Only displayed when FU1-75 is set to 'Yes'.

FU2 GROUP

CODE	Comm. Addr	Description	LCD Keypad Display	Setting Range	Factory Default	Adj. During Run
FU2-00	9300	Jump to desired code #	Jump code	1 to 95 (Use Only LCD Keypad)	40	○
FU2-01	9301	Last trip 1	Last trip-1	By pressing [ENTER] and [SEL] key, the frequency, current, and operational status at the time of fault can be seen.	0 (None)	×
FU2-02	9302	Last trip 2	Last trip-2		0 (None)	×
FU2-03	9303	Last trip 3	Last trip-3		0 (None)	×
FU2-04	9304	Last trip 4	Last trip-4		0 (None)	×
FU2-05	9305	Last trip 5	Last trip-5		0 (None)	×
FU2-06	9306	Erase trips	Erase trips	0 (No) 1 (Yes)	0 (No)	○
FU2-07	9307	Dwell Frequency	Dwell time	0 to 10 [sec]	0 [sec]	×
FU2-08 <small>Note12)</small>	9308	Dwell Frequency	Dwell freq	FU1-32 to FU1-30	5.00[Hz]	×
FU2-10	930A	Frequency Jump Selection	Jump Freq	0 (No) 1 (Yes)	0 (No)	×
FU2-11 <small>Note13)</small>	930B	Jump Frequency 1 Low	jump lo 1	0 to FU2-12	10.00[Hz]	○
FU2-12	930C	Jump Frequency 1 High	jump Hi 1	FU2-11 to FU1-30	15.00[Hz]	○
FU2-13	930D	Jump Frequency 2 Low	jump lo 2	0 to FU2-14	20.00[Hz]	○
FU2-14	930E	Jump Frequency 2 High	jump Hi 2	FU2-13 to FU1-30	25.00[Hz]	○
FU2-15	930F	Jump Frequency 3 Low	jump lo 3	0 to FU2-16	30.00[Hz]	○
FU2-16	9310	Jump Frequency 3 High	jump Hi 3	FU2-15 to FU1-30	35.00[Hz]	○
FU2-20	9314	Power ON Start Selection	Power-on run RST restart	0 (No) 1 (Yes)	0 (No)	○
FU2-21	9315	Restart after Fault Reset	RST restart	0 (No) 1 (Yes)	0 (No)	○
FU2-22	9316	Start After Interrupt Power	IPF Mode Fault Selection	0 (No) 1 (Yes)	0(No)	×
FU2-23	9317	Speed Search Type Selection	Search Type	Estimated SS Real SS	Estimated SS	○
FU2-24	9318	Selection of Auto Retry	Retry Mode	No Yes	No	○
FU2-25	9319	Number of Auto Retry	Retry number	0 to 10	0	○
FU2-26 <small>Note15)</small>	931A	Delay Time Before Auto Retry	Retry delay	0 to 60 [sec]	1 [sec]	×
FU2-27	931B	Speed Search Current Limit	Flying Perc	30 to 160	70%	×
FU2-40	9328	Rated Motor Selection for drive (0.75~450kW)	Motor select	0 (0.75kW) 1 (1.5kW) 2 (2.2kW) 3 (3.7kW) 4 (5.5kW) 5 (7.5kW) 6 (11.0kW) 7 (15.0kW) 8 (18.5kW) 9 (22.0kW) 10 (30.0kW) 11 (37.0kW) 12 (45.0kW) 13 (55.0kW) 14 (75.0kW) 15 (90.0kW) 16 (110.0kW) 17 (132.0 kW) 18 (160.0 kW) 18 (220.0 kW) 20 (280.0 kW) 21 (315.0 kW) 22 (375.0 kW) 23 (450.0 kW)	* Depending on the drive capacity	×
* A motor rating same as drive capacity is automatically set. If different, set the correct value.						
FU2-41	9329	Number of Motor Poles	Pole number	2 to 12	4	×
FU2-42	932A	Rated Motor Slip	Rate-Slip	0 to 10 [Hz]	Depending on the motor capacity	×
FU2-43	932B	Rated Motor Current (RMS)	Rated-Curr	1.0 to 999.9 [A]	Depending on the motor capacity	×

The gray-highlighted codes are hidden parameters and will appear when the related functions are to be set.

Note 12) Only displayed when FU2-07 is set to [1~10 sec].

13) FU2-11 is displayed when FU2-10 is set to [Yes].

14) FU2-26 is displayed when FU2-25 [Retry number] is set to [1~10].

15) FU2-64 is displayed when FU2-60 is set to [Sensorless].

Parameter Description

FU2 GROUP

CODE	Comm. Addr	Description	LCD Keypad Display	Setting Range	Factory Default	Adj. During Run	
FU2-44	932C	No Load Motor Current(rms)	Noload-Curr	0.1 to 999.9 [A]	Depending on the motor capacity	×	
FU2-46	932E	Load Inertia	Inertia rate	0 to 40	10	×	
FU2-47	932F	Gain for Motor Speed Display	RPM DisplayGn	1 to 1000 [%]	100 [%]	○	
FU2-48	9330	Carrier Frequency	Carrier freq	0.75~22kW	0.7~15[kHz]	5.0 [kHz]	○
				30kW	0.7~10[kHz]		
				37~75kW	0.7~4[kHz]	4.0 [kHz]	
				90~280kW	0.7~3[kHz]	3.0 [kHz]	
				315~450kW	0.7~2[kHz]	2.0 [kHz]	
FU2-49	9331	PWM Type Selection	PWM Select	0 (Normal) 1 (Low leakage)	0 (Normal)	×	
FU2-52	9334	Safety Stop Dec. Rate	Dec Rate	1.0 to 100.0 [sec]	100.0 [sec]		
FU2-53	9335	Safety Stop Output Dec. Rate	safety_perc	2 to 500	21		
FU2-60	933C	Control Mode Selection	Control Mode	0 (V/F)	0 (V/F)	×	
				1 (Slip compen)			
				2 (Sensorless)			
FU2-61	933D	Auto Tuning Selection	Auto Tuning	0 (No) 1 (Static)	0 (No)	×	
FU2-62	933E	Stator Resistance of Motor	%Rs	0.01 to 20 [%]	4[%]	×	
FU2-63	933F	Leakage Inductance of Motor	%Lsigma	0.01 to 100 [%]	12[%]	×	
FU2-64 <small>Note16)</small>	9340	Pre-excitation Time	PreEx time	0 to 60 [sec]	1 [sec]	×	
FU2-67	9343	Manual/Auto Torque Boost Selection	Torque boost	0 (Manual)	0 (Manual)	×	
				1 (Auto)			
FU2-68	9344	Torque Boost in Forward Direction	Fwd boost	0.75~90kW	0 to 15 [%]	×	
				110~450kW			
FU2-69	9345	Torque Boost in Reverse Direction	Rev boost	0.75~90kW	0 to 15 [%]	×	
				110~450kW			
FU2-80	9350	Power On display	PowerOn Disp	0 to 12	0	○	
FU2-81	9351	User Select	User Disp	Voltage Watt	Voltage	○	
FU2-82	9352	Software Version	iP5A S/W Ver	Ver X.X Ver	X.X	*	
FU2-83	9353	Last Trip Time	LastTripTime	X:XX:XX:XX:XX:X	*	×	
FU2-84	9354	Power On Time	On-time	X:XX:XX:XX:XX:X	*	×	
FU2-85	9355	Run-time	Run-time	X:XX:XX:XX:XX:X	*	×	
FU2-87	9357	Power Set	Power Set	0.01 to 400 [%]	100	×	
FU2-90	935A	Parameter Display	Para. disp	0 Default	0 (Default)	×	
				1 (All Para)			
				2 (Diff Para)			
FU2-91	935B	Read Parameter	Para. Read	0 (No)	0 (No)	×	
				1 (Yes)			
FU2-92	935C	Write Parameter	Para. Write	0 (No)	0 (No)	×	
				1 (Yes)			
FU2-93	935D	Initialize Parameters	Para. Init	0 (No)	0 (No)	×	
				1 (All Groups)			
				2 (BAS)			
				3 (DRV)			
				4 (FU1)			
				5 (FU2)			
				6 (I/O)			
				7 (EXT)			
				8 (COM)			
9 (APP)							
FU2-94	935E	Parameter Write Protection	Para. Lock	0 to 9999	0	○	
FU2-95	935F	Parameter Save	Para. Save	0 (No)	0 (No)	×	
				1 (Yes)			

□ The gray-highlighted codes are hidden parameters and will appear when the related functions are to be set.

Note 16) FU2-64 is displayed when FU2-60 is set to [Sensorless].

Table 1) Switching frequency and factory default value for each drive capacity

Drive Capacity	Setting Range	Factory Default
0.75 ~ 22 kW	0.7 ~ 15 [kHz]	5.0 [kHz]
30 kW	0.7 ~ 10 [kHz]	
37 ~ 75 kW	0.7 ~ 4 [kHz]	4.0 [kHz]
90 ~ 280 kW	0.7 ~ 3 [kHz]	3.0 [kHz]
315 ~ 450 kW	0.7 ~ 2 [kHz]	2.0 [kHz]

I/O GROUP

CODE	Comm. Addr	Description	LCD Keypad Display	Setting Range	Factory Default	Adj. During Run
I/O-00	9400	Jump to Desired Code #	Jump code	1 to 98	1	○
I/O-01 <small>Note17</small>	9401	Filtering Time Constant for V1 Signal Input	V1 Filter	0 to 9999 [msec]	10 [msec]	○
I/O-02	9402	V1 Input Minimum Voltage	V1 volt x1	0 to 12[V]	0.00 [V]	○
I/O-03	9403	Frequency Corresponding to V1 Input Minimum Voltage	V1 Freq y1	0 to FU1-30 [Hz] 0 to 100.00 [**] <small>Note18</small>	0.00 [Hz]	○
I/O-04	9404	V1 Input Minimum Voltage	V1 volt x2	0 to 12[V]	10 [V]	○
I/O-05	9405	V1 Input Maximum Voltage	V1 Freq y2	0 to FU1-30 [Hz] 0 to 100.00 [**] <small>Note18</small>	60.00 [Hz]	○
I/O-06	9406	Filtering Time Constant for I Signal Input	I Filter	0 to 9999 [msec]	10 [msec]	○
I/O-07	9407	I Input Minimum Current	I curr x1	0 to 20 [mA]	4 [mA]	○
I/O-08	9408	Frequency Corresponding to I Input Minimum Current	I Freq y1	0 to FU1-30 [Hz] 0 to 100.00 [**] <small>Note18</small>	0.00 [Hz]	○
I/O-09	9409	Filtering Time Constant for I Signal Input	I curr x2	0 to 20 [mA]	20 [mA]	○
I/O-10	940A	Frequency Corresponding to I Input Maximum Current	I Freq y2	0 to FU1-30 [Hz] 0 to 100.00 [**] <small>Note18</small>	60.00 [Hz]	○
I/O-11	940B	Pulse Input Method	P Pulse set	0 (A+B) 1 (A)	1 (A)	○
I/O-12	940C	Pulse Input Filter	P filter	0 to 9999 [msec]	10 [msec]	○
I/O-13	940D	Pulse Input Minimum Frequency	P pulse x1	0 to 10 [kHz]	0 [kHz]	○
I/O-14	940E	Frequency Corresponding to I/O-13 Pulse Input Minimum Frequency	P freq y1	0 to FU1-30 [Hz] 0 to 100.00 [**] <small>Note18</small>	0 [Hz]	○
I/O-15	940F	Pulse Input Maximum Frequency	P pulse x2	0 to 100 [kHz]	10 [kHz]	○
I/O-16	9410	Frequency Corresponding to I/O-15 Pulse Input Maximum Frequency	P freq y2	0 to FU1-30 [Hz] 0 to 100.00 [**] <small>Note18</small>	60.00 [Hz]	○
I/O-17	9411	Criteria for Analog Input Signal Loss	Wire broken	0 (None) 1 (half of x1) 2 (below x1)	0 (None)	○
I/O-18	9412	Operating selection at Loss of Freq. Reference	Lost command	0 (None) 1 (FreeRun) 2 (Stop) 3 (Protection)	0 (None)	○
I/O-19	9413	Waiting Time after Loss of Freq. Reference	Time out	0.1 to 120 [sec]	1.0 [sec]	○
I/O-20	9414	Programmable Digital Input Terminal 'M1' Define	M1 Define	0 (Speed-L) 1 (Speed-M) 2 (Speed-H) 3 (XCEL-L) 4 (XCEL-M) 5 (XCEL-H) 6 (Dc-brake) 7 (2nd Func) 8 (Exchange) 9 (- Reserved -) 10 (Up) 11 (Down) 13 (Ext Trip)	0 (Speed-L)	○

The gray-highlighted codes are hidden parameters and will appear when the related functions are to be set.

Note 17 When DRV-04 is set to either V1, V1S, I or V1+I or Pulse, only selected item codes are displayed in I/O-1~I/O-19.

18 I/O-3,5,8,10,14,16 is displayed 0-100.00 [**] when App-02 is set to [proc PI mode] or APP-80 is set to [Ext PI mode] and APP-06 PID Feedback Signal Selection is set to one of I, V, Pulse, after then, one of I/O-86 ~I/O-88 is set to percentage, Bar, mBar, kPa, Pa except for Speed. Unit will be changed to selected unit. Only user unit displayed when APP-02 or APP-80 is set to [Yes], after APP-06 is set to one of I, V, Pulse, after then one of I/O-86 ~I/O-88 is set to either speed, percentage, Bar, mBar, kPa, Pa.

iP5A

Parameter Description

I/O GROUP

CODE	Comm. Addr	Description	LCD Keypad Display	Setting Range	Factory Default	Adj. During Run
I/O-20	9414	Programmable Digital Input Terminal 'M1' Define	M1 Define	14 (Pre-Heat)	0 (Speed-L)	○
				15 (Term Clear)		
				16 (Open-loop)		
				17 (LOC/REM)		
				18 (Analog hold)		
				19 (XCEL stop)		
				20 (P Gain2)		
				21 -Reserved-		
				22 (Interlock1)		
				23 (Interlock2)		
				24 (Interlock3)		
				25 (Interlock4)		
				26 (Speed_X)		
				27 (RST)		
				28 (BX)		
				29 (JOG)		
				30 (FX)		
31 (RX)						
32 (ANA_CHG)						
33 (Pre-Excite)						
34 (Ext PID Run)						
35 (Up/Dn Clr)						
I/O-21	9415	Programmable Digital Input Terminal 'M2' Define	M2 define	Same as I/O-20	1 (Speed-M)	○
I/O-22	9416	Programmable Digital Input Terminal 'M3' Define	M3 define	Same as I/O-20	2 (Speed-H)	○
I/O-23	9417	Programmable Digital Input Terminal 'M4' Define	M4 define	Same as I/O-20	27 (RST)	○
I/O-24	9418	Programmable Digital Input Terminal 'M5' Define	M5 define	Same as I/O-20	12 (Stop/3-wire)	○
I/O-25	9419	Programmable Digital Input Terminal 'M6' Define	M6 define	Same as I/O-20	29 (JOG)	○
I/O-26	941A	Programmable Digital Input Terminal 'M7' Define	M7 define	Same as I/O-20	30 (FX)	○
I/O-27	941B	Programmable Digital Input Terminal 'M8' Define	M8 define	Same as I/O-20	31 (RX)	○
I/O-28	941C	Terminal Input Status	In status	0000000000/1111111111	0000000000	*
I/O-29	941D	Filtering Time Constant for Programmable Digital Input Terminals	Ti Filt Num	2 to 1000 [msec]	15	○
I/O-30 <small>Note19)</small>	941E	Jog Frequency Setting	Jog Freq	0 to FU1-30	10 [Hz]	○
I/O-31	941F	Step Frequency 4	Step Freq-4		40 [Hz]	○
I/O-32	9420	Step Frequency 5	Step Freq-5		50 [Hz]	○
I/O-33	9421	Step Frequency 6	Step Freq -6		40 [Hz]	○
I/O-34	9422	Step Frequency 7	Step Freq-7		30 [Hz]	○
I/O-35	9423	Step Frequency 8	Step Freq -8		20 [Hz]	○
I/O-36	9424	Step Frequency 9	Step Freq -9		10 [Hz]	○
I/O-37	9425	Step Frequency 10	Step Freq -10		20 [Hz]	○
I/O-38	9426	Step Frequency 11	Step Freq -11		30 [Hz]	○

The gray-highlighted codes are hidden parameters and will appear when the related functions are to be set.
 Note 19) I/O-30 ~ I/O-34 displayed only when one of I/O-20 ~ I/O-27 is set to either JOG, Speed_L, Speed_M, Speed_H. I/O-35 ~ I/O-42 displayed only when one of I/O-20 ~ I/O-27 is set to Speed_X.

CODE	Comm. Addr	Description	LCD Keypad Display	Setting Range	Factory Default	Adj. During Run	
I/O-39	9427	Step Frequency 12	Step Freq-12	0 to FU1-30	40 [Hz]	○	
I/O-40	9428	Step Frequency 13	Step Freq-13		50 [Hz]	○	
I/O-41	9429	Step Frequency 14	Step Freq-14		40 [Hz]	○	
I/O-42	942A	Step Frequency 15	Step Freq-15		30 [Hz]	○	
I/O-50	9432	Acceleration Time 1 (for Step speed)	Acc time-1	0 to 6000 [sec]	20 [sec]	○	
I/O-51	9433	Deceleration Time 1 (for Step speed)	Dec time-1	0 to 6000 [sec]	20 [sec]	○	
I/O-52 <small>Note20)</small>	9434	Acceleration Time 1 (for Step speed)	Acc time-2	0 to 6000 [sec]	30 [sec]	○	
I/O-53	9435	Deceleration Time 2	Dec time-2	0 to 6000 [sec]	30 [sec]	○	
I/O-54	9436	Acceleration Time 3	Acc time-3	0 to 6000 [sec]	40 [sec]	○	
I/O-55	9437	Deceleration Time 3	Dec time-3	0 to 6000 [sec]	40 [sec]	○	
I/O-56	9438	Acceleration Time 4	Acc time-4	0 to 6000 [sec]	50 [sec]	○	
I/O-57	9439	Deceleration Time 4	Dec time-4	0 to 6000 [sec]	50 [sec]	○	
I/O-58	943A	Acceleration Time 5	Acc time-5	0 to 6000 [sec]	40 [sec]	○	
I/O-59	943B	Deceleration Time 5	Dec time-5	0 to 6000 [sec]	40 [sec]	○	
I/O-60	943C	Acceleration Time 6	Acc time-6	0 to 6000 [sec]	30 [sec]	○	
I/O-61	943D	Deceleration Time 6	Dec time-6	0 to 6000 [sec]	30 [sec]	○	
I/O-62	943E	Acceleration Time 7	Acc time-7	0 to 6000 [sec]	20 [sec]	○	
I/O-63	943F	Deceleration Time 7	Dec time-7	0 to 6000 [sec]	20 [sec]	○	
I/O-70	9446	S0 Output Selection	S0 mode	0	(Frequency)	0 (Frequency)	○
				1	(Current)		
				2	(Voltage)		
				3	(DC link Vtg)		
				4	(Ext PID Out)		
I/O-71	9447	S0 Output Adjustment	S0 adjust	10 to 200 [%]	100 [%]	○	
I/O-72	9448	S1 Output Selection	S1 mode	Same as I/O-70	2 (Voltage)	○	
I/O-73	9449	S1 Output Adjustment	S1 adjust	10 to 200 [%]	100 [%]	○	
I/O-74 <small>Note21)</small>	944A	Frequency Detection Level	FDT freq	0 to FU1-30 [Hz]	30.00 [Hz]	○	
I/O-75	944B	Frequency Detection Bandwidth	FDT band	0 to FU1-30 [Hz]	10.00 [Hz]	○	
I/O-76	944C	Programmable Digital Output Terminal Define (Aux terminal)	Aux Mode1	0	(NONE)	0 (NONE)	○
				1	(FDT-1)		
				2	(FDT-2)		
				3	(FDT-3)		
				4	(FDT-4)		
				5	(FDT-5)		
				6	(OL)		
				7	(IOL)		
				8	(Stall)		
				9	(OV)		
				10	(LV)		
				11	(OH)		
				12	(Lost Command)		
				13	(Run)		
				14	(Stop)		
15	(Steady)						

Gray The gray-highlighted codes are hidden parameters and will appear when the related functions are to be set.
 Note 20) I/O-52 ~ I/O-63 displayed only when one of I/O-20 ~ I/O-27 is set to either XCEL_L, XCEL_M, XCEL_H.
 21) I/O-74 ~ I/O-75 displayed only when one of I/O-76 ~ I/O-79 is set to either FDT-1~FDT5

Parameter Description

I/O GROUP

CODE	Comm. Addr	Description	LCD Keypad Display	Setting Range	Factory Default	Adj. During Run	
I/O-76	944C	Output Terminal Define	Aux Mode1	16	(INV line)	0 (NONE)	○
				17	(COMM line)		
				18	(SpeedSearch)		
				19	(Ready)		
				20	(MMC)		
				21	(CriticalTrip)		
I/O-77	944D	Programmable Digital Output Terminal Define	Aux mode2	Same as I/O-76	0 (NONE)	○	
I/O-78	944E	Programmable Digital Output Terminal Define	Aux mode3	Same as I/O-76	0 (NONE)	○	
I/O-79	944F	Programmable Digital Output Terminal Define	Aux mode4	Same as I/O-76	0 (NONE)	○	
I/O-80	9450	Fault Output Relay Setting (3A, 3B, 3C)	Relay mode	000 to 111 [bit]	010 [bit]	○	
I/O-81	9451	Terminal Output Status	Out status	00000000/11111111	00000000	*	
I/O-82	9452	Waiting Time after Fault Output Relay On	Relay On	0 to 9999	0	×	
I/O-83	9453	Waiting Time after Fault Output Relay Off	Relay Off	0 to 9999	0	×	
I/O-84	9454	Fan Con Sel (37 ~ 90kW)	Fan Con. Sel	0	(Power On Fan)	0 (Power On Fan)	×
				1	(Run Fan)		
				2	(Temper-Fan)		
I/O-85	9455	Fan Temp (37 ~ 90kW)	Fan Temp	0 to 70 [°C]	70 [°C]	○	
I/O-86	9456	Input User Unit Selection	Unit Sel	0	(Percent)	0 (Percent)	×
				1	(Bar)		
				2	(mBar)		
				3	(kPa)		
				4	(PSI)		
				5	(Pa)		
I/O-87	9457	Unit Maximum Selection	Unit Max Val	1.0 to 999.9[%]	100[%]	×	
I/O-90	945A	Drive Number	Inv No.	1 to 250	1	○	
I/O-91 <small>Note22)</small>	945B	Baud Rate Selection	Baud rate	0	(1200 bps)	3 (9600 bps)	○
				1	(2400 bps)		
				2	(4800 bps)		
				3	(9600 bps)		
				4	(19200 bps)		
				5	(38400 bps)		
I/O-92 <small>Note23)</small>	945C	Operating Method at Loss of Freq. Reference	COM Lost Cmd	0	(None)	0 (None)	○
				1	(FreeRun)		
				2	(Stop)		
I/O-93	945D	Waiting Time after Loss of Freq. Reference	COM Time Out	0.1 to 120 [sec]	1.0 [sec]	○	
I/O-94	945E	Communication Response Delay time	Delay Time	2 to 1000 [msec]	5 [msec]	○	
I/O-95	945F	A or B contact	In No/Nc Set	0000000000/1111111111	0000000000	×	
I/O-96	9460	Input time	In CheckTime	1 to 1000	1 [msec]	×	
I/O-97	9461	Overheat Trip Selection	OH Trip Sel	000 to 111 [bit]	010 [bit]	×	
I/O-98	9462	Motor Overheat Trip Temperature	MO Trip Temp	0 to 255 [°C]	110 [°C]	×	

 The gray-highlighted codes are hidden parameters and will appear when the related functions are to be set.

Note 22) 38400 bps can be set only when the external communication option card is installed.

23) Only I/O-92 ~ I/O-93 displayed when DRV-03/04 is set to [int485].

APP GROUP

CODE	Comm. Addr	Description	LCD Keypad Display	Setting Range	Factory Default	Adj. During Run
APP-00	9700	Jump to Desired Code #	Jump code	1 to 80	1	○
APP-01	9701	Application Mode Selection	App mode	0 (None)	0 (None)	×
				1 (MMC)		
APP-02	9702	PID Operation Selection	Proc PI mode	0 (No)	0 (No)	×
				1 (Yes)		
APP-03 <small>Note25)</small>	9703	PID F Gain Selection	PID F-Gain	0 to 999.9[%]	0.0 [%]	○
APP-04 <small>Note26)</small>	9704	PID Auxiliary Reference Mode Selection	Aux Ref Enbl	0 (No)	0 (No)	×
				1 (Yes)		
APP-05 <small>Note27)</small>	9705	PID Auxiliary Reference Signal Selection	Aux Ref Sel	0 (Keypad-1)	2 (V1)	×
				1 (Keypad-2)		
				2 (V1)		
				3 (V1S)		
				4 (I)		
				5 (V1+)		
				6 (Pulse)		
				7 (Int. 485)		
				8 (Ext. PID)		
APP-06	9706	PID Feedback Signal Selection	PID F/B	0 (I)	0 (I)	×
				1 (V1)		
				2 (Pulse)		
APP-07	9707	Meter I Maximum Value	Meter I Max	0 to 20.00 mA	20.00 mA	○
APP-08	9708	Meter V Maximum Value	Meter V Max	0 to 12.00 V	10.00V	○
APP-09	9709	Meter P Maximum Value	Meter P Max	0 to 100.0kHz	100.0kHz	○
APP-11	970B	P Gain for PID Control	PID P Gain	0 to 999.9 [%]	1.0 [%]	○
APP-12	970C	I Time for PID Control	PID I Time	0 to 32.0 [sec]	10.0 [sec]	○
APP-13	970D	D Time for PID Control	PID D Time	0 to 100 [msec]	0.0 [msec]	○
APP-14	970E	High Limit Frequency for PID Control	PID Hi Limit	0.00 to FN1-30	60.00[Hz]	○
APP-15	970F	Low Limit Frequency for PID Control	PID LowLimit	FN1-32 to APP-10	0.5 [Hz]	○
APP-16	9710	PID Output Gain	PID OutScale	0.0 to 999.9 [%]	100.0 [%]	×
APP-17	9711	PID P2 Gain	PID P2 Gain	0.0 to 999.9 [%]	100.0 [%]	×
APP-18	9712	P Gain Scale	P Gain Scale	0.0 to 100.0 [%]	100.0 [%]	×
APP-19	9713	PID Output Inverse	PID OutInv.	0 (No)	0 (No)	×
				1 (Yes)		
APP-20	9714	PID U Curve Feedback Select	PID U Fbk	0 (No)	0 (No)	×
				1 (Yes)		
APP-23	9717	PrePID Reference Frequency	PrePID Freq	0 to FU1-30	0	○
APP-24	9718	PrePID Exit Level	PrePID Exit	0 to 100.0%	0	○
APP-25	9719	PrePID Stop delay	PrePID Dly	0 to 9999	600	○
APP-26	971A	Pipe Broken	Pipe Broken	0 (No)	0 (No)	×
				1 (Yes)		
APP-27	971B	Sleep Delay Time	Sleep Delay	0.0 to 9999 [sec]	60.0 [sec]	○
APP-28	971C	Sleep Frequency	Sleep Freq	0 to FU1-30 [Hz]	0.00 [Hz]	○
APP-29	971D	Wake-Up Level	WakeUp level	0.0 to 100.0 [%]	2.0[%]	○
APP-30 <small>Note28)</small>	971E	2nd Acceleration Time	2nd Acc Time	0 to 6000 [sec]	5 [sec]	○
APP-31	971F	2nd Deceleration Time	2nd Dec Time	0 to 6000 [sec]	10 [sec]	○
APP-32	9720	2nd Base Frequency	2nd BaseFreq	30 to FN1-30 [Hz]	60 [Hz]	×
APP-33	9721	2nd V/F Pattern	2nd V/F	0 (Linear)	0 (Linear)	×
				1 (Square)		
				2 (User V/F)		
APP-34	9722	2nd Forward Torque Boost	2nd F-Boost	0.0 to 15.0 [%]	2.0 [%]	×
APP-35	9723	2nd Reverse Torque Boost	2nd R-Boost	0.0 to 15.0 [%]	2.0 [%]	×
APP-36	9724	2nd Stall Prevention Level	2nd Stall	30 to 150 [%]	100 [%]	×
APP-37	9725	2nd Electronic Thermal Level for 1 Minute	2nd ETH 1min	FU2-28 to 200 [%]	130[%]	○

□ The gray highlighted codes are hidden parameters and will appear when the related functions are to be set.
 Note 25) Only APP-03 ~ APP-17 displayed when APP-02 is set to [Yes]. Only APP-03 ~ APP-17 and APP-63 ~ APP-65 displayed when APP-2 is set to [Yes].
 26) If APP-04 Aux Ref Mode is no set, DRV-04 setting will be reference of process PID. And APP -05 setting will be ignored
 27) If APP-04 is set, APP-04 will appear. And APP -05 setting value will be reference of process PID, DRV-04 setting will be ignored.
 28) Only APP-20 ~ APP-29 displayed only when one of I/O-20 ~ I/O-27 is set to either □□2nd Func□□.

Parameter Description

APP GROUP

CODE	Comm. Addr	Description	LCD Keypad Display	Setting Range	Factory Default	Adj. During Run	
APP-38	9726	2nd Electronic Thermal Level for Continuous	2nd ETH Cont	50 to FU2-27 (Max 150%)	120[%]	○	
APP-39	9727	2nd Rated Motor Current	2nd R-Curr	1 to 200 [A]	3.6[A]	×	
APP-40 <small>Note29)</small>	9728	Number of Auxiliary Motor Run Display	Aux Mot Run	*	*	*	
APP-41	9729	Aux. Motor Start Selection	Starting Aux	1 to 4	1	○	
APP-42	972A	Operation Time Display on Auto Change	Auto Op Time	*	*	*	
APP-43	972B	The Number of Aux Motor	Nbr Aux's	0 to 7	4	○	
APP-44	972C	Aux. Motor Stop Sequence	F-in L-Out	0	(No)	1 (Yes)	×
				1	(Yes)		
APP-45	972D	How to stop Aux. Motor	ALL Stop	0	(No)	1 (Yes)	×
				1	(Yes)		
APP-47	972F	Start Frequency of Aux. Motor 1	Start freq 1	0 to FU1-30	49.99 [Hz]	○	
APP-48	9730	Start Frequency of Aux. Motor 2	Start freq 2	0 to FU1-30	49.99 [Hz]	○	
APP-49	9731	Start Frequency of Aux. Motor 3	Start freq 3	0 to FU1-30	49.99 [Hz]	○	
APP-50	9732	Start Frequency of Aux. Motor 4	Start freq 4	0 to FU1-30	49.99 [Hz]	○	
APP-51	9733	Stop Frequency of Aux. Motor 1	Stop freq 1	0 to FU1-30	20.00 [Hz]	○	
APP-52	9734	Stop Frequency of Aux. Motor 2	Stop freq 2	0 to FU1-30	20.00 [Hz]	○	
APP-53	9735	Stop Frequency of Aux. Motor 3	Stop freq 3	0 to FU1-30	20.00 [Hz]	○	
APP-54	9736	Stop Frequency of Aux. Motor 4	Stop freq 4	0 to FU1-30	20.00 [Hz]	○	
APP-58	973A	Delay Time before Operating Aux Motor	Aux start DT	0.0 to 999.9 [sec]	5.0 [sec]	○	
APP-59	973B	Delay Time before Stopping Aux Motor	Aux stop DT	0.0 to 999.9 [sec]	5.0 [sec]	○	
APP-60	973C	Accel Time when the Number of Pump Decreases	Pid AccTime	0 to 600.0 [sec]	2.0 [sec]	○	
APP-61	973D	Decel Time when the Number of Pump Increases	Pid DecTime	0 to 600.0 [sec]	2.0 [sec]	○	
APP-62	973E	PID Bypass Selection	Regul Bypass	0	(No)	0 (No)	×
				1	(Yes)		
APP-66	9742	Auto Change Mode Selection	AutoCh_Mode	0	(EXCH_NONE),	0(EXCH_NONE)	○
				1	(AUX_EXCH),		
				2	(MAIN_EXCH)		
APP-67	9743	Auto Change Time	AutoEx-intv	00:00 to 99:00	72:00	○	
APP-68	9744	Auto Change Freq	AutoEx-Freq	FN1-32 to FN1-30[Hz]	20.0 [Hz]	○	
APP-69	9745	Inter-Lock Selection	Inter-lock	0 (No)	0 (No)	○	
APP-71	9747	Pressure difference for Aux motor Start	Aux Stt Diff	0 to100%	2[%]	○	
APP-72	9748	Pressure difference for Aux motor Stop	Aux Stp Diff	0 to100%	2[%]	○	
APP-80	9750	Ext PID Operation Selection	Ext PI Mode	0	(No)	0 (No)	×
				1	(Yes)		
APP-81 <small>Note30)</small>	9751	Ext PID Reference Signal Selection	ExtPI RefSel	0	(I)	3(Keypad)	×
				1	(V1)		
				2	(Pulse)		
				3	(Keypad)		
APP-82	9752	Ext PID Reference Level	Ext PI Ref %	0 to 100.00 [%]	50.00 [%]	×	
APP-83	9753	Ext PID Feedback Signal Selection	ExtPI FbkSel	0	(I)	0 (I)	×
				1	(V1)		
				2	(Pulse)		
APP-85	9755	P Gain for ExtPID	ExtPID Pgain	0 to 999.9 [%]	1.0 [%]	×	
APP-86	9756	I Time for ExtPID	ExtPID Itime	0 to 32.0 [sec]	10.0 [sec]	×	
APP-87	9757	D Time for ExtPID	ExtPID Dtime	0 to 2000 [msec]	0 [msec]	×	
APP-88	9758	High Limit Frequency for ExtPID Control	ExtPID Lmt-H	0 to 100.00 [%]	100.00 [%]	×	
APP-89	9759	Low Limit Frequency for ExtPID Control	ExtPID Lmt-L	0 to 30.00 [%]	0 [%]	×	
APP-90	975A	ExtPID Output Scale	ExtPID Scale	0 to 999.9	100.0 [%]	×	
APP-91	975B	ExtPID P2 Gain	ExtPI P2Gain	0 to 999.9	100.0 [%]	×	
APP-92	975C	ExtPID P Gain Scale	ExtPI PScale	0 to 100.0	100.0 [%]	×	
APP-93	975D	ExtPID F Gain	ExtPID F-gain	0 to 999.9 [%]	0.0 [%]	○	
APP-95	975F	ExtPID Output Inverse	ExtPI OutInv	0	(No)	0 (No)	×
				1	(Yes)		
APP-97	9761	ExtPID Loop Time	ExtPI LoopTm	50 to 200 [msec]	100 [msec]	×	

□ The gray-highlighted codes are hidden parameters and will appear when the related functions are to be set.

Note 29) Only APP-40 ~ APP-71 displayed when APP-01 is set to [MMC].

30) Only APP-81 ~ APP-97 displayed when APP-80 Ext PI mode is set to [Yes].

EXT GROUP

CODE	Comm. Addr	Description	LCD Keypad Display	Setting Range	Factory Default	Adj. During Run
EXT-00	9500	Jump to Desired Code #	Jump code	1 to 45	1	○
EXT-01	9501	Type of SUB Board	Sub B/D	Sub-E	*	*
				Frequency		
				Current		
EXT-40	9528	Current Output Terminal 1(CO1) Selection	AM1 mode	Voltage	Frequency	○
				DC link Vtg		
				Ext PID Out		
EXT-41	9529	Adjust Gain of Current Output Terminal 1(CO1)	AM1 adjust	10-200 [%]	100 [%]	○
EXT-42	952A	Adjust Offset of Current Output Terminal 1(CO1)	AM1 Offset	0-100 [%]	0 [%]	○
				Frequency		
				Current		
EXT-43	952B	Current Output Terminal 2(CO2) Selection	AM2 mode	Voltage	DC link Vtg	○
				DC link Vtg		
				Ext PID Out		
EXT-44	952C	Adjust Gain of Current Output Terminal 2(CO2)	AM2 adjust	10-200 [%]	100 [%]	○
EXT-45	952D	Adjust Offset of Current Output Terminal 2(CO2)	AM2 Offset	0-100 [%]	0 [%]	○

* Only the above EXT group displayed when the corresponding option board is installed.
 * Refer to the SUB board option manual for details.

COM GROUP

CODE	Comm. Addr	Description	LCD Keypad Display	Setting Range	Factory Default	Adj. During Run
COM-00	9600	Jump to Desired Code #	Jump code	1 to 60	1	○
COM-01	9601	Type of SUB Board	Opt B/D	RS485	*	*
				DeviceNet		
				Profibus		
				BACnet		
				LonWork		
COM-02	9602	Option Mode	Opt mode	None	None	×
				Command		
				Freq		
				Cmd + Freq		
COM-03	9603	Option Version	Opt Version	Ver X.X	Ver X.X	*
COM-13	960D	Device Net Input Instance	In Instance	70	70	×
				71		
				110		
				111		
COM-17	9611	PLC Station ID	Station ID	0 to 63	1	○
COM-20	9614	Profi MAC ID	Profi MAC ID	1 to 127	1	○
COM-30	961E	Output Num	Output Num	0 to 8	3	○
COM-31	961F	Output 1	Output 1	0000-FFFF (HEX)	000A(HEX)	○

Parameter Description

COM GROUP

CODE	Comm. Addr	Description	LCD Keypad Display	Setting Range	Factory Default	Adj. During Run
COM-32	9620	Output 2	Output 2	0000-FFFF (HEX)	000E(HEX)	○
COM-33	9621	Output 3	Output 3	0000-FFFF (HEX)	000F(HEX)	○
COM-34	9622	Output 4	Output 4	0000-FFFF (HEX)	0000(HEX)	○
COM-35	9623	Output 5	Output 5	0000-FFFF (HEX)	0000(HEX)	○
COM-36	9624	Output 6	Output 6	0000-FFFF (HEX)	0000(HEX)	○
COM-37	9625	Output 7	Output 7	0000-FFFF (HEX)	0000(HEX)	○
COM-38	9626	Output 8	Output 8	0000-FFFF (HEX)	0000(HEX)	○
COM-40	9628	Input Num	Input Num	0 - 8	2	○
COM-41	9629	Input 1	Input 1	0000-FFFF (HEX)	0005(HEX)	○
COM-42	962A	Input 2	Input 2	0000-FFFF (HEX)	0006(HEX)	○
COM-43	962B	Input 3	Input 3	0000-FFFF (HEX)	0000(HEX)	○
COM-44	962C	Input 4	Input 4	0000-FFFF (HEX)	0000(HEX)	○
COM-45	962D	Input 5	Input 5	0000-FFFF (HEX)	0000(HEX)	○
COM-46	962E	Input 6	Input 6	0000-FFFF (HEX)	0000(HEX)	○
COM-47	962F	Input 7	Input 7	0000-FFFF (HEX)	0000(HEX)	○
COM-48	9630	Input 8	Input 8	0000-FFFF (HEX)	0000(HEX)	○
COM-60	963C	Parity/Stop	Parity/Stop 8	None/1Stop	8None/1Stop	○
				8None/2Stop		
				8Even/1Stop		
				8Odd/1Stop		
COM-61	963D	Opt Para-1	Opt Para-1	0 to FFFF	0	○
COM-62	963E	Opt Para-2	Opt Para-2	0 to FFFF	0	○
COM-63	963F	Opt Para-3	Opt Para-3	0 to FFFF	0	○
COM-64	9640	Opt Para-4	Opt Para-4	0 to FFFF	0	○
COM-65	9641	Opt Para-5	Opt Para-5	0 to FFFF	0	○
COM-66	9742	Opt Para-6	Opt Para-6	0 to FFFF	0	○
COM-67	9743	Comm UpDate	Comm UpDate	0	(No)	0 (No)
				1	(Yes)	

* Only the above COM group displayed when the corresponding option board is installed.
 * COM-61~66 parameter is used to LonWorks and BACnet communication.

Trial Run

■ Operation Example (1)

V/F Control + Analog Voltage Input (V1)
+ Operation via Terminal (FX/RX)

Operation condition

- Control mode: V/F control
- Frequency command: 50 [Hz] analog input via V1 terminal
- Accel/Decel time: Accel -15 [sec], Decel -25 [sec]
- Drive mode: Run/Stop via FX/RX terminal, Control terminal: NPN mode

Wiring

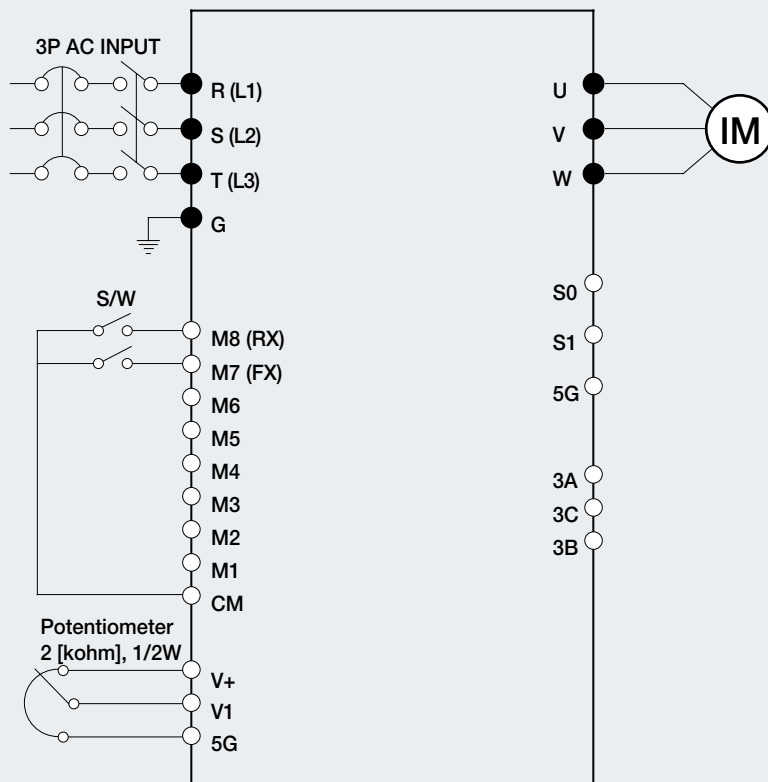

Step	Parameter setting	Code	Description
1	Control Mode Selection	FU2-60	Set it to 0 (V/F).
2	Drive Mode	DRV-3	Set it to Fx/Rx-1.
3	Frequency Mode	DRV-4	Set V1 Analog input value in frequency mode.
4	50 [Hz] Freq Command Setting	DRV-0	Set freq command 50 [Hz] via V1 (Potentiometer).
5	Accel/Decel Time	DRV-1 DRV-2	Set Accel time to 15 [sec] in DRV-2. Set Decel time to 25 [sec] in DRV-3.
6	Terminal FX	I/O-26	Motor starts to rotate in forward direction at 50Hz with Accel time 15 [sec] when FX terminal is turned ON. Motor decelerates to stop with Decel time 25 [sec] when FX terminal is turned OFF.
7	Terminal RX	I/O-27	When RX terminal is turned ON motor starts to rotate in Reverse direction at 50 [Hz] with Accel time 15 [sec]. When it is OFF, motor decelerates to stop with Decel time 25 [sec].

Operation Example (2)

V/F control + Analog input (V1S)
+ Operation via terminal FX/RX

Operation condition

- Control mode: V/F control
- Frequency command:
Setting 50 [Hz] via Analog input (V1S)
- Accel/Decel time: Accel time 15 [sec],
Decel time 25 [sec]
- Drive mode: Run/Stop via FX/RX,
Control terminal: NPN mode

Wiring

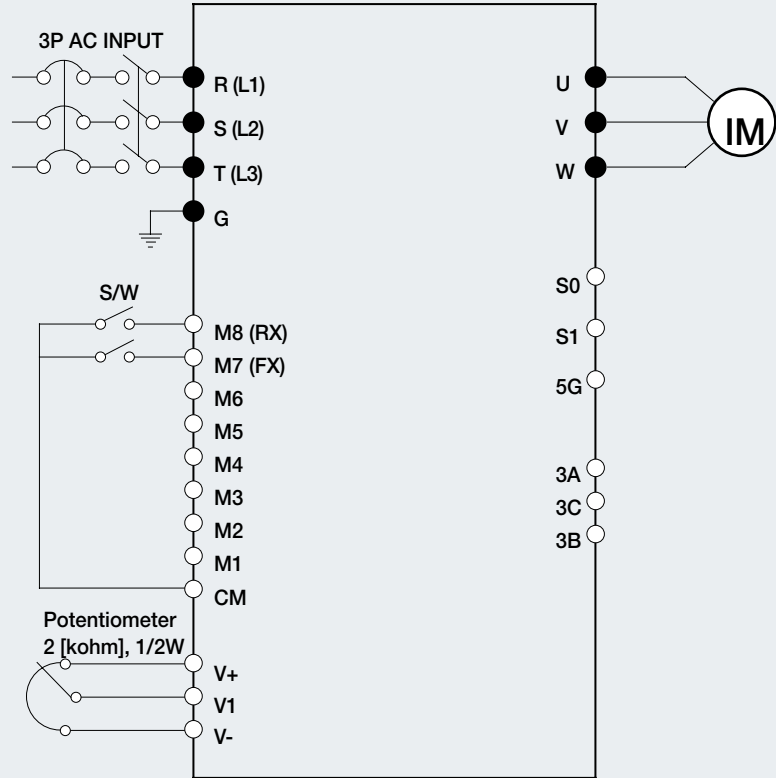

Step	Parameter setting	Code	Description
1	Control Mode Selection	FU2-60	Set it to 0 (V/F).
2	Drive Mode	DRV-3	Set it to 1 (Fx/Rx-1).
3	Frequency Mode	DRV-4	Set it to 3 (V1S).
4	Operating Frequency Command 50 [Hz] Setting	DRV-0	Set 50 [Hz] via potentiometer (V1S).
5	Accel/Decel Time Setting	DRV-1 DRV-2	Set accel time to 15 [sec] in DRV-1 with decal time to 25 [sec] in DRV-2.
6	FX Terminal (M7)	IO-26	When FX terminal is turned ON, motor rotating in forward direction starts running at 50 [Hz] for 15 [sec]. When FX terminal is turned OFF, motor decelerates to stop for 25 [sec].
7	RX Terminal (M8)	IO-27	When RX terminal is turned ON, motor rotating in reverse direction starts running at 50 [Hz] for 15 [sec]. When RX terminal is turned OFF, motor decelerates to stop for 25 [sec].

Dimensions

SV008~055iP5A (200/400V Class) & SV055~110iP5A (600V Class)

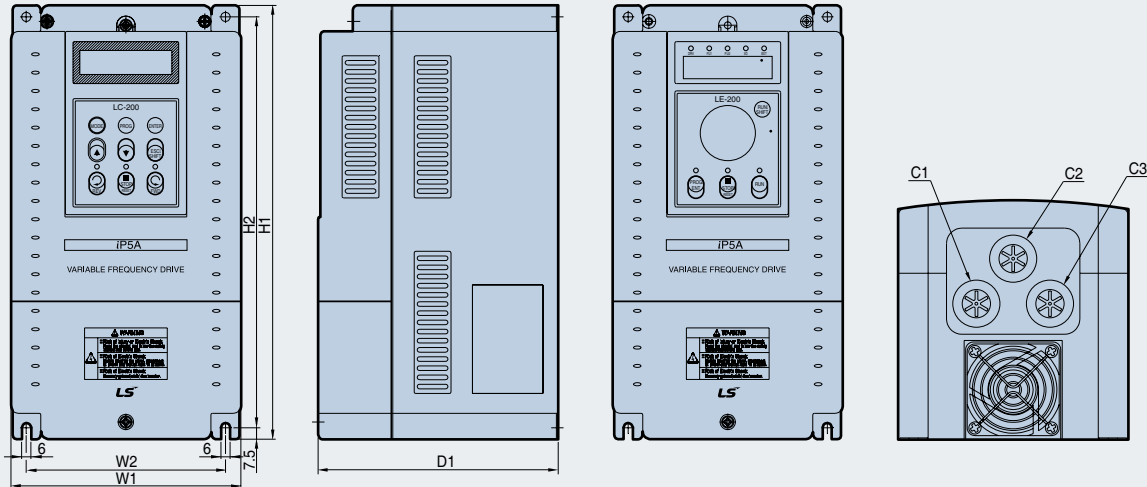

mm (inches)

Model	W1	W2	H1	H2	D1	C1	C2	C3	Enclosure Type
SV008iP5A-2/4	150 (5.91)	130 (5.12)	284 (11.18)	269 (10.69)	156.5 (6.16)	24 (0.98)	24 (0.98)	24 (0.98)	IP20 UL Type 1
SV015iP5A-2/4	150 (5.91)	130 (5.12)	284 (11.18)	269 (10.69)	156.5 (6.16)	24 (0.98)	24 (0.98)	24 (0.98)	IP20 UL Type 1
SV022iP5A-2/4	150 (5.91)	130 (5.12)	284 (11.18)	269 (10.69)	156.5 (6.16)	24 (0.98)	24 (0.98)	24 (0.98)	IP20 UL Type 1
SV037iP5A-2/4	150 (5.91)	130 (5.12)	284 (11.18)	269 (10.69)	156.5 (6.16)	24 (0.98)	24 (0.98)	24 (0.98)	IP20 UL Type 1
SV055iP5A-2/4	150 (5.91)	130 (5.12)	284 (11.18)	269 (10.69)	156.5 (6.16)	24 (0.98)	24 (0.98)	24 (0.98)	IP20 UL Type 1
SV055iP5A-6	200(7.87)	180(7.09)	355(13.98)	340(13.39)	182.5(7.19)	28.5(1.12)	24(0.94)	28.5(1.12)	IP 20 UL Type 1
SV075iP5A-6	200(7.87)	180(7.09)	355(13.98)	340(13.39)	182.5(7.19)	28.5(1.12)	24(0.94)	28.5(1.12)	IP 20 UL Type 1
SV110iP5A-6	200(7.87)	180(7.09)	355(13.98)	340(13.39)	182.5(7.19)	28.5(1.12)	24(0.94)	28.5(1.12)	IP 20 UL Type 1

SV075~300iP5A (200/400V Class) & SV150~300iP5A (600V Class)

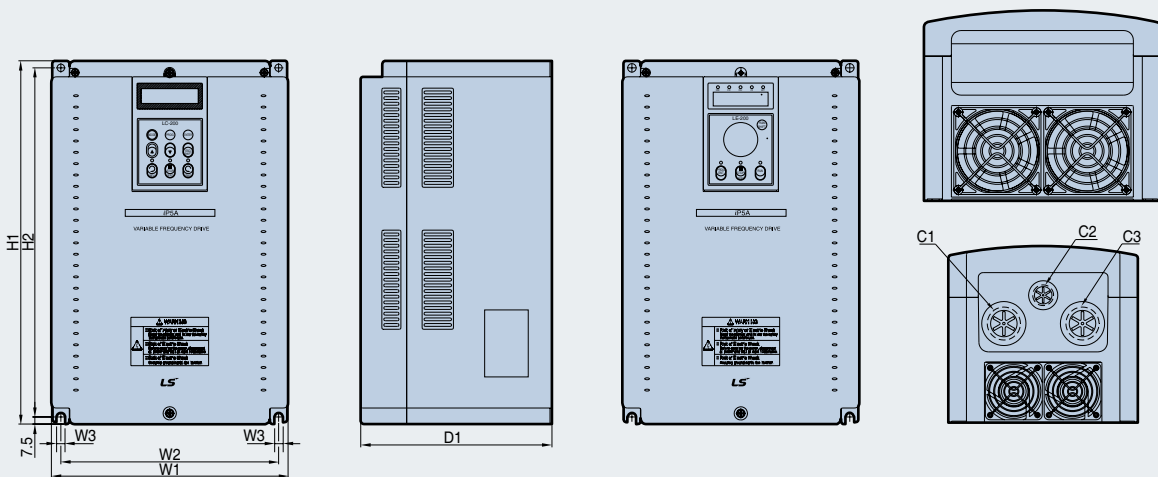

mm (inches)

Model	W1	W2	W3	H1	H2	D1	C1	C2	C3	Enclosure Type
SV075iP5A-2/4	200 (7.87)	180 (7.09)	6 (0.23)	284 (11.18)	269 (10.69)	182 (7.16)	35 (1.37)	24 (0.98)	35 (1.37)	IP20 UL Type 1
SV110iP5A-2/4	200 (7.87)	180 (7.09)	6 (0.23)	284 (11.18)	269 (10.69)	182 (7.16)	35 (1.37)	24 (0.98)	35 (1.37)	IP20 UL Type 1
SV150iP5A-2/4/6	250 (9.84)	230 (9.06)	9 (0.35)	385 (15.16)	370 (14.57)	201 (7.91)	-	-	-	IP00 UL Open
SV185iP5A-2/4/6	250 (9.84)	230 (9.06)	9 (0.35)	385 (15.16)	370 (14.57)	201 (7.91)	-	-	-	IP00 UL Open
SV220iP5A-2/4/6	304 (11.97)	284 (11.18)	9 (0.35)	460 (18.11)	445 (17.52)	234 (9.21)	-	-	-	IP00 UL Open
SV300iP5A-2/4/6	304 (11.97)	284 (11.18)	9 (0.35)	460 (18.11)	445 (17.52)	234 (9.21)	-	-	-	IP00 UL Open

iP5A

Dimensions

■ SV150~300iP5A (UL Type 1 or UL Open Type with Conduit Option used, 200V/400V Class)

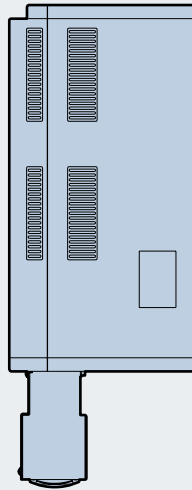
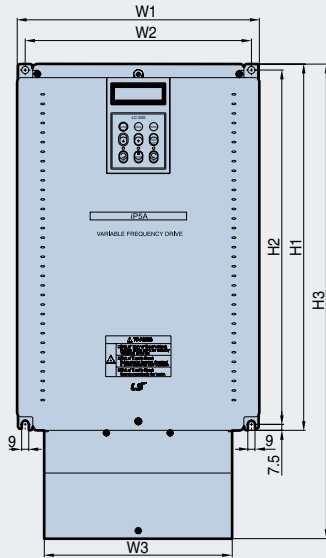

Note) Mounting NEMA 1 conduit option to the 15-90kW (20-125HP) Open Type meets NEMA 1 but does not comply with UL Enclosed Type 1. To that end, please purchase UL Type 1 product.

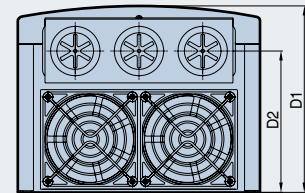

mm (inches)

Model	W1	W2	H1	H2	H3	D1	D2	C3	Enclosure Type
SV150iP5A-2/4	250 (9.84)	230 (9.06)	200.8 (7.9)	385 (15.16)	370 (14.57)	454.2 (17.88)	201 (7.91)	146 (5.74)	IP20 UL Type 1
SV185iP5A-2/4	250 (9.84)	230 (9.06)	200.8 (7.9)	385 (15.16)	370 (14.57)	454.2 (17.88)	201 (7.91)	146 (5.74)	IP20 UL Type 1
SV220iP5A-2/4	304 (11.97)	284 (11.18)	236 (9.29)	460 (18.11)	445 (17.52)	599.2 (23.59)	234 (9.21)	177.5 (6.98)	IP20 UL Type 1
SV300iP5A-2/4	304 (11.97)	284 (11.18)	236 (9.29)	460 (18.11)	445 (17.52)	599.2 (23.59)	234 (9.21)	177.5 (6.98)	IP20 UL Type 1

■ SV150~SV300 iP5A (400V Class)–Built-in DCL Type

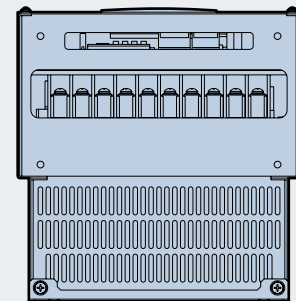
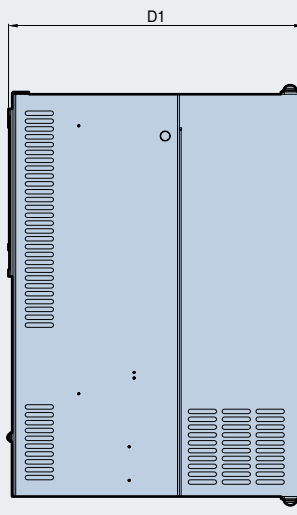
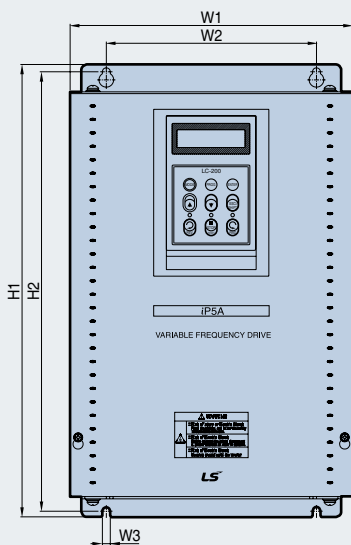

mm (inches)

Model	W1	W2	W3	H1	H2	D1	Enclosure Type
SV150, 185iP5A-4L	250 (9.84)	186 (7.32)	7 (0.28)	403.5 (15.88)	392 (15.43)	261.2 (10.28)	IP00 UL Type 1
SV220, 300iP5A-4L	260 (10.23)	220 (8.66)	7 (0.28)	480 (18.89)	468.5 (18.44)	268.6 (10.57)	IP20 UL Type 1

SV150~SV300 iP5A (Built-in DCL Type, UL Type 1 or UL Open Type with Conduit Option used, 400V Class)

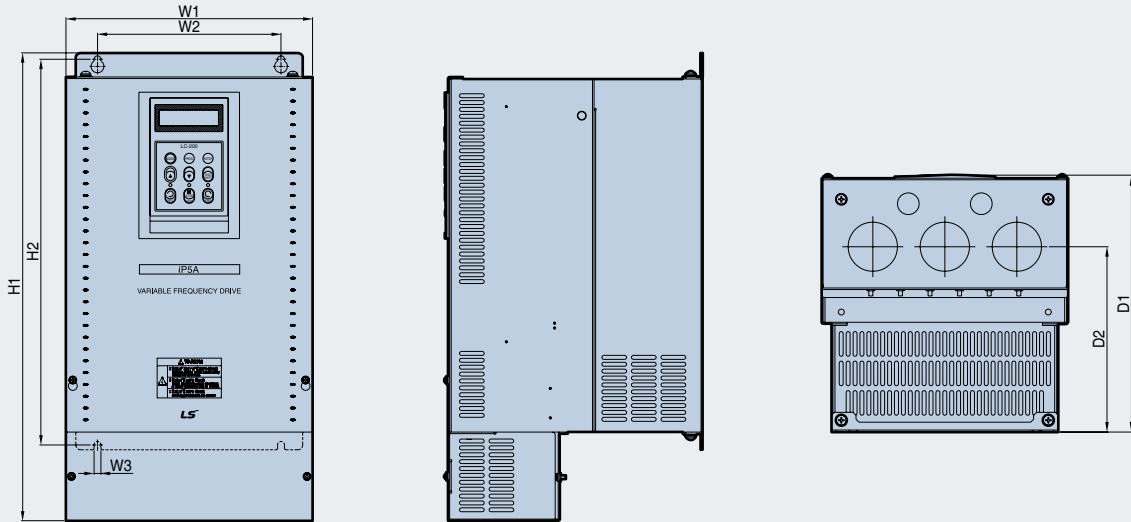

mm (inches)

Model	W1	W2	W3	H1	H2	D1	D2	Enclosure Type
SV150, 185iP5A-4L	250 (9.84)	186 (7.32)	7 (0.28)	475.5 (18.72)	392 (15.43)	261.2 (10.28)	188.4 (7.42)	IP20 UL Type 1
SV220, 300iP5A-4L	260 (10.23)	220 (8.66)	7 (0.28)	552 (21.73)	468.5 (18.44)	268.6 (10.57)	188.8 (7.43)	IP20 UL Type 1

SV370~SV550iP5A (400V Class) & SV370~550iP5A (600V Class)

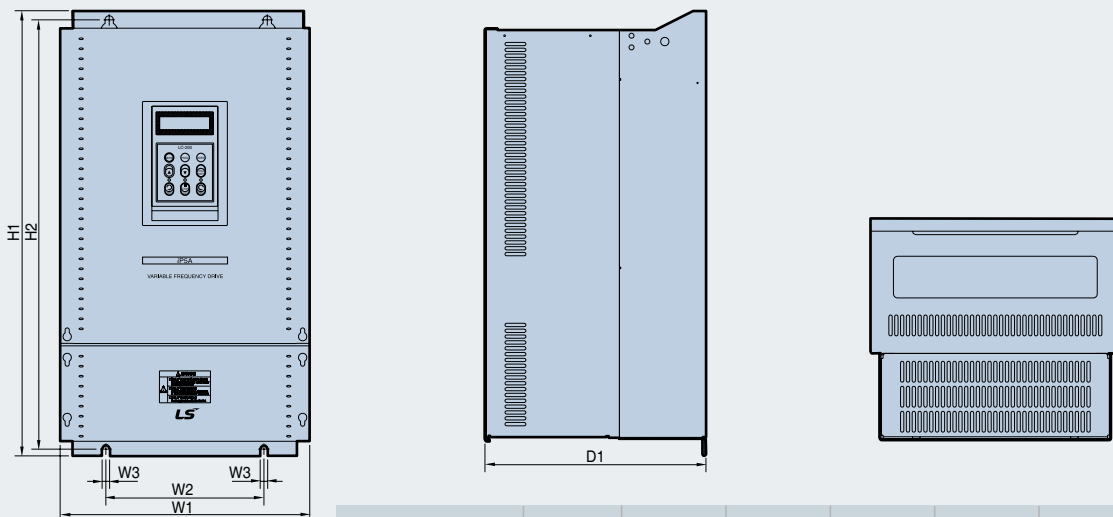

mm (inches)

Model	W1	W2	W3	H1	H2	D1	Enclosure Type
SV370, 450iP5A-4	300 (11.81)	190 (7.48)	9 (0.35)	534 (21.02)	515 (20.28)	265.6 (10.46)	IP00 UL Open
SV550iP5A-4, SV370 450, 550iP5A-6	300 (11.81)	190 (7.48)	9 (0.35)	534 (21.02)	515 (20.28)	292.6 (11.52)	IP00 UL Open
SV370, 450iP5A-4L (Built-in DCL Type)	300 (11.81)	190 (7.48)	9 (0.35)	684 (26.92)	665 (26.18)	265.6 (10.46)	IP00 UL Open
SV550iP5A-4L (Built-in DCL Type)	300 (11.81)	190 (7.48)	9 (0.35)	684 (26.92)	665 (26.18)	292.6 (11.52)	IP00 UL Open

iP5A

Dimensions

■ SV370~550iP5A (UL Type 1 or UL Open Type with Conduit Option Used, 400V Class)

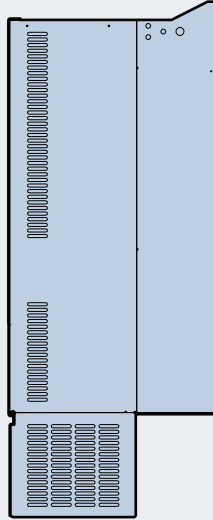
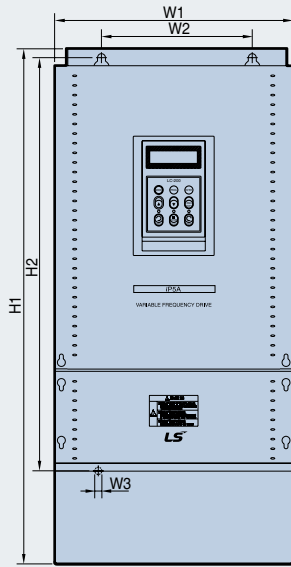

Note) Mounting NEMA 1 conduit option to the 15~90kW (20~125HP) Open Type meets NEMA 1 but does not comply with UL Enclosed Type 1. To that end, please purchase UL Type 1 product.

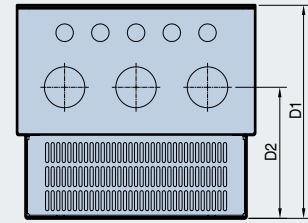

mm (inches)

Model	W1	W2	W3	H1	H2	D1	D2	Enclosure Type
SV370, 450iP5A-4	300 (11.81)	190 (7.48)	9 (0.35)	642 (25.28)	515 (20.28)	265.6 (10.46)	163.4 (6.43)	IP20 UL Type 1
SV550iP5A-4	300 (11.81)	190 (7.48)	9 (0.35)	642 (25.28)	515 (20.28)	292.6 (11.52)	190.4 (7.5)	IP20 UL Type 1
SV370, 450iP5A-4L	300 (11.81)	190 (7.48)	9 (0.35)	792 (31.18)	665 (26.18)	265.6 (10.46)	163.4 (6.43)	IP20 UL Type 1
SV550iP5A-4L	300 (11.81)	190 (7.48)	9 (0.35)	792 (31.18)	665 (26.18)	292.6 (11.52)	190.4 (7.5)	IP20 UL Type 1

■ SV750, 900iP5A (400V Class) & SV750~900iP5A (600V Class)

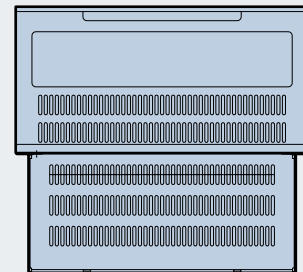
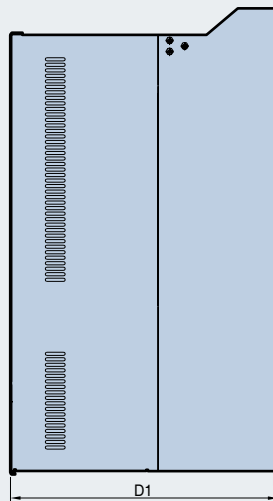
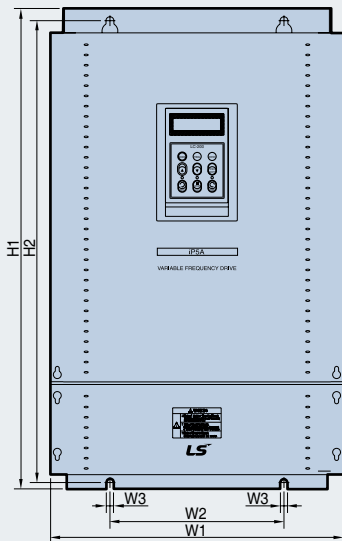

mm (inches)

Model	W1	W2	W3	H1	H2	D1	Enclosure Type
SV750, 900iP5A-4	370 (14.57)	220 (8.66)	9 (0.35)	610 (24.02)	586.5 (23.09)	337.6 (13.29)	IP00 UL Open
SV750, 900iP5A-6	370 (14.57)	220 (8.66)	9 (0.35)	610 (24.02)	586.5 (23.09)	337.6 (13.29)	IP00 UL Open
SV750, 900iP5A-4L (Built-in DCL Type)	370 (14.57)	220 (8.66)	9 (0.35)	760 (29.92)	736.6 (28.99)	337.6 (13.29)	IP00 UL Open

■ ■ SV750, 900iP5A (UL Type 1 or UL Open Type with Conduit Option used, 400V Class)

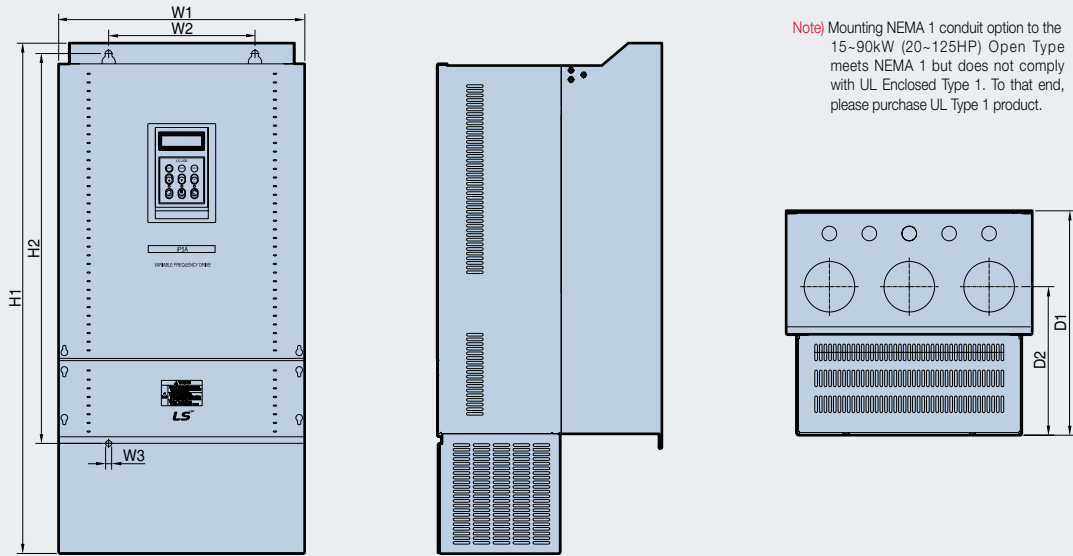

Note) Mounting NEMA 1 conduit option to the 15-90kW (20-125HP) Open Type meets NEMA 1 but does not comply with UL Enclosed Type 1. To that end, please purchase UL Type 1 product.

mm (inches)

Model	W1	W2	W3	H1	H2	D1	D2	Enclosure Type
SV750, 900iP5A-4	370 (14.57)	220 (8.66)	9 (0.35)	767.5 (30.22)	586.5 (23.09)	337.6 (13.29)	223.4 (8.8)	IP20 UL Type 1
SV750, 900iP5A-4L (Built-in DCL Type)	370 (14.57)	220 (8.66)	9 (0.35)	917.5 (36.12)	736.5 (28.99)	337.6 (13.29)	223.4 (8.8)	IP20 UL Type 1

■ ■ SV1100, 1600iP5A (400V Class) & SV1100iP5A (600V Class)

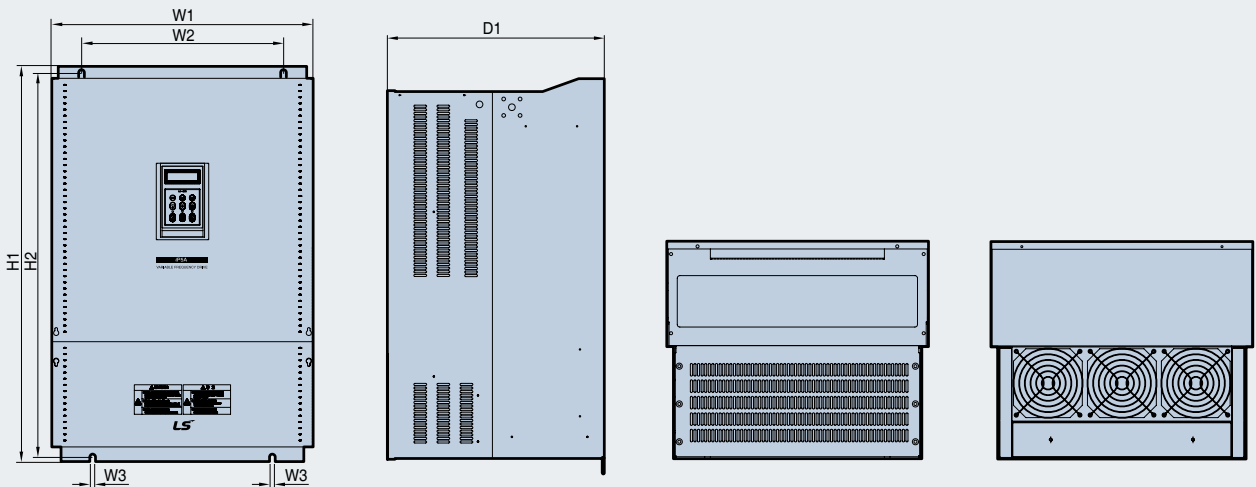

mm (inches)

Model	W1	W2	W3	H1	H2	D1	Enclosure Type
SV1100, 1320iP5A-4L	510 (20.08)	381 (15.00)	11 (0.43)	783.5(30.85)	759(29.88)	422.6 (16.64)	IP00 UL Open
SV1100iP5A-6L	510 (20.08)	381 (15.00)	11 (0.43)	861(33.90)	836.5(32.93)	422.6 (16.64)	IP00 UL Open

iP5A

■ SV2200, 2800iP5A (400V Class)

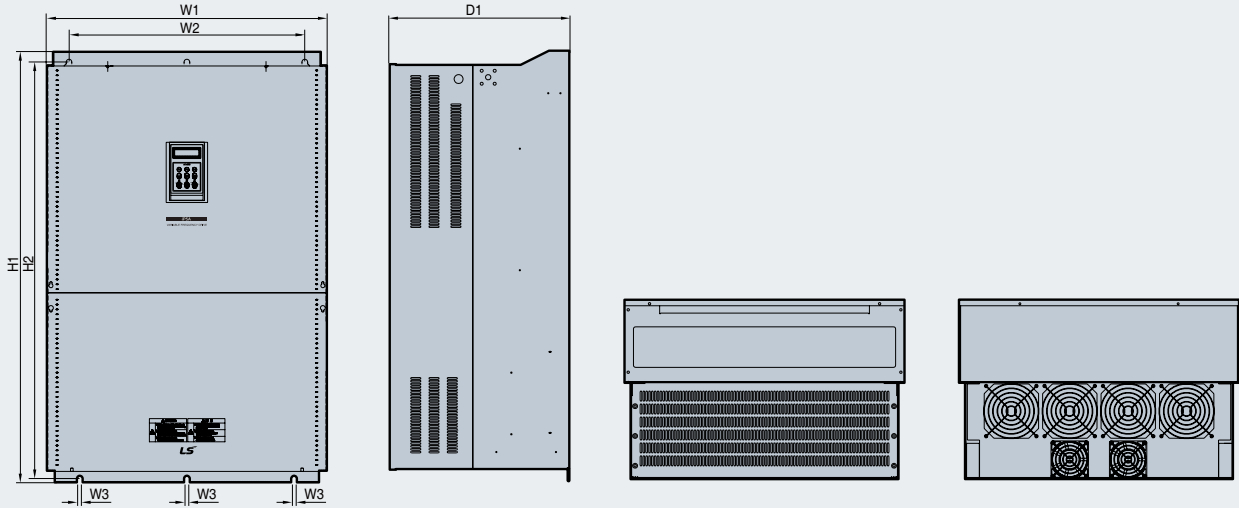

mm (inches)

Model	W1	W2	W3	H1	H2	D1	Enclosure Type
SV2200, 2800iP5A-4L	690 (27.17)	581 (22.87)	14 (0.55)	1063 (41.85)	1043.5 (41.08)	449.6 (17.70)	IP00 UL Open

■ SV3150~4500iP5A (400V Class)

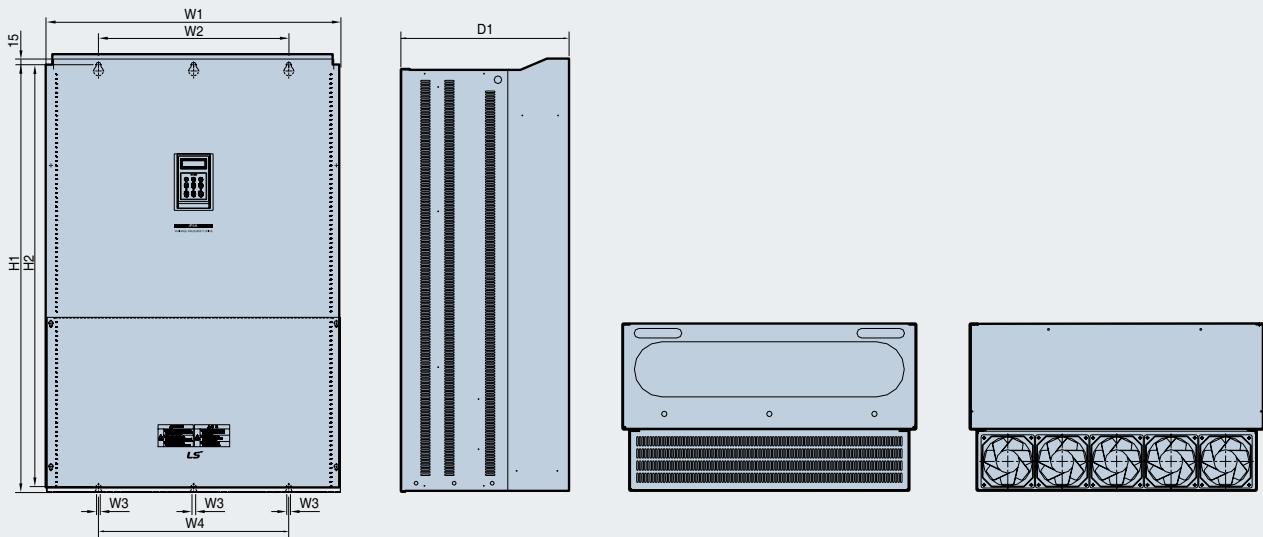

mm (inches)

Model	W1	W2	W3	H1	H2	D1	Enclosure Type
SV3150, iP5A-4L	772 (30.39)	500 (19.69)	13 (0.51)	1140.5 (44.90)	1110 (43.70)	442 (17.40)	IP00 UL Open
SV3750, 4500iP5A-4L	922 (36.30)	580 (22.83)	14 (0.55)	1302.5 (51.28)	1271.5 (50.06)	495 (19.49)	IP00 UL Open

DB (Dynamic Braking) Unit

DBU Models

UL	Drive	Applicable motor rating	DB Unit	Dimension
Non UL type	200V class	11~15 kW (15~20 HP)	SV150DBU-2	Group 1.
		18.5~22 kW (25~30 HP)	SV220DBU-2	
		30~37 kW (40~50 HP)	SV037DBH-2	Group 2.
		45~55 kW (60~75 HP)	SV037DBH-2, 2set	
	400V class	11~15 kW (15~20 HP)	SV150DBU-4	Group 1.
		18.5~22 kW (25~30 HP)	SV220DBU-4	
		30~37 kW (40~50 HP)	SV037DBH-4	Group 2.
		45~55 kW (60~75 HP)	SV075DBH-4	
		75 kW (100 HP)		
UL type	200V class	11~15 kW (15~20 HP)	SV150DBU-2U	Group 3.
		18.5~22 kW (25~30 HP)	SV220DBU-2U	
		30~37 kW (40~50 HP)	SV370DBU-2U	
		45~55 kW (60~75 HP)	SV550DBU-2U	
	400V class	11~15 kW (15~20 HP)	SV150DBU-4U	
		18.5~22 kW (25~30 HP)	SV220DBU-4U	
		30~37 kW (40~50 HP)	SV370DBU-4U	
		45~55 kW (60~75 HP)	SV550DBU-4U	
		75 kW (100 HP)	SV750DBU-4U	
		90~110 kW (125~150 HP)	SV550DBU-4, 2set	
		132~160 kW (200~250 HP)	SV750DBU-4, 2set	
		220 kW (300 HP)	SV750DBU-4, 3set	
		280~315 kW (350~400 HP)	-	
		375~450 kW (500~600 HP)	-	

Terminal Configuration

- Group 1 - **CM** **OH** **G** **B2** **B1** **N** **P**
- Group 2 - **G** **N** **B2** **P/B1**
- Group 3 - **P** **N** **G** **B1** **B2**

Terminals	Description	Terminals	Description
G	Ground terminal	N	Connect to drive terminal N
B2	Connect to DB Resistor's B2	P	Connect to drive terminal P1
B1	Connect to DB Resistor's B1	CM	OH common
N	Connect to drive terminal N	OH*	Over Heat Trip output terminal (Open Collector output: 20mA, 27V DC)
P	Connect to drive terminal P1		

■ Wiring for DB unit and DB resistor (For 5.5~90kW/7.5~125HP drives)

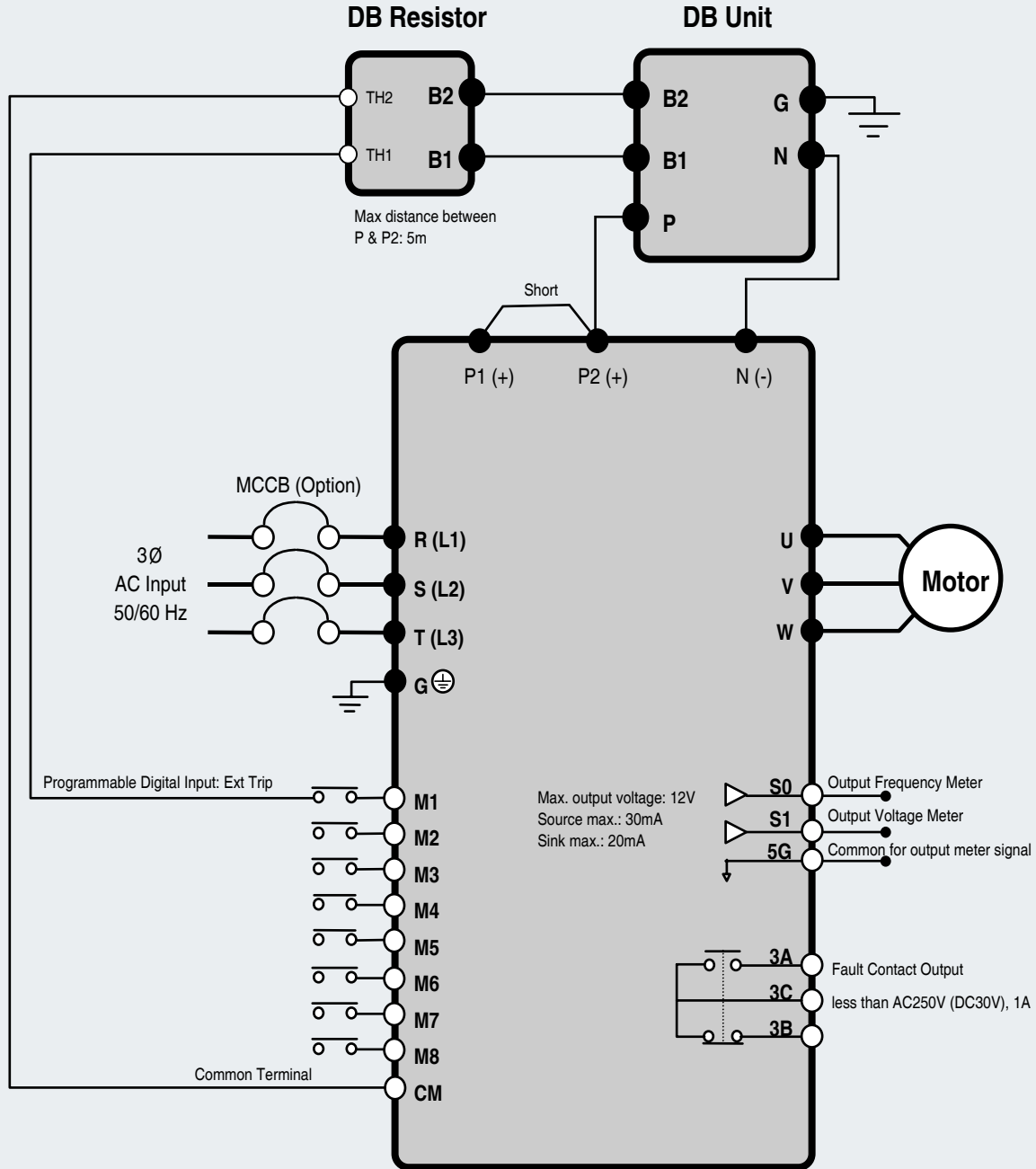

DB resistor terminal	Description
B1, B2	Wire terminal properly based on wiring block diagram. Connect a DB resistor to the DB Unit's B1, B2 terminals.
TH1, TH2	Thermal sensor terminal of DB resistor. Normal temperature (Ambient): Contact ON (TH1-TH2 closed) DB resistor overheated: Contact OFF (TH1-TH2 Open). Wire it to the drive terminal defined as External Trip.

DB (Dynamic Braking) Unit

Group 1

(Unit: mm)

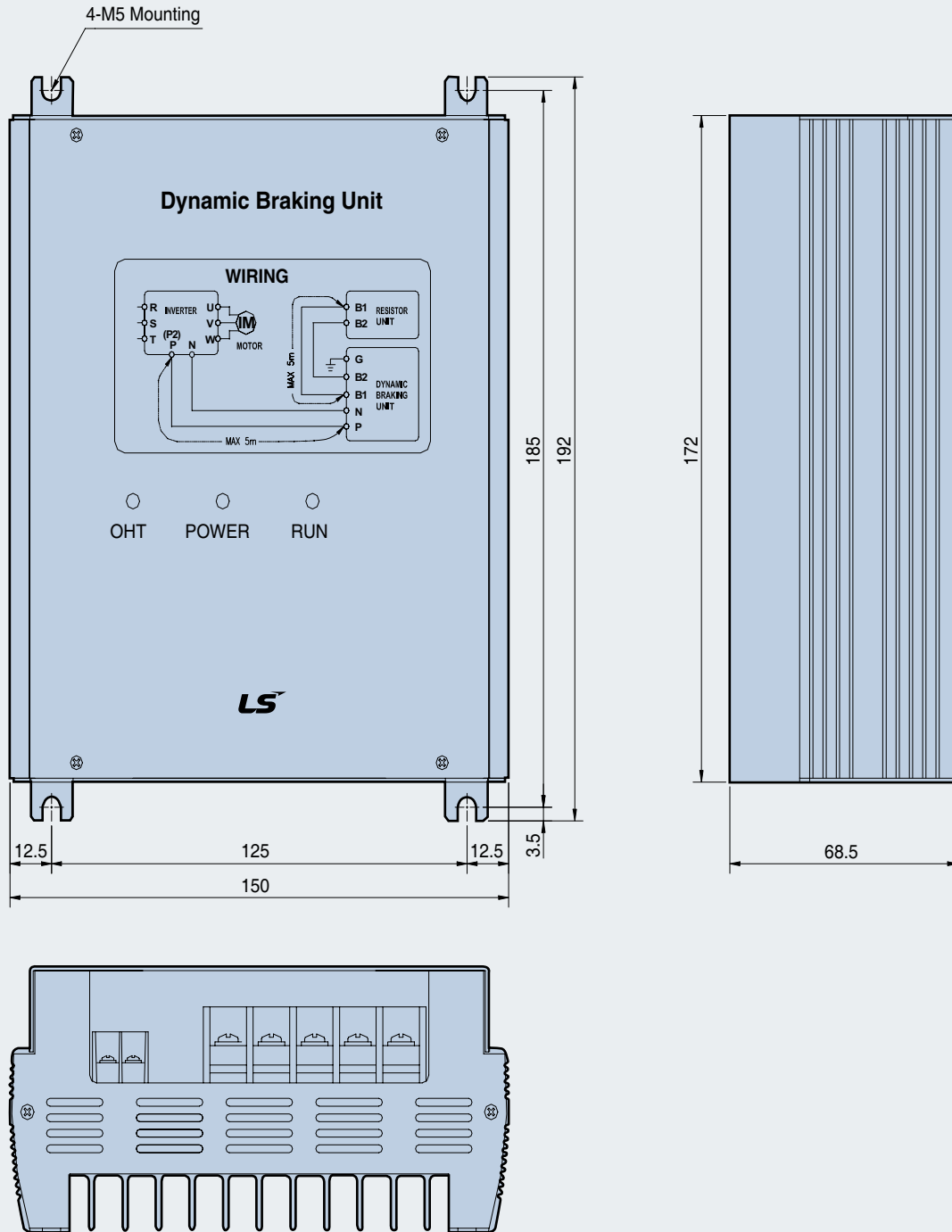

iP5A

Group 2

(Unit: mm)

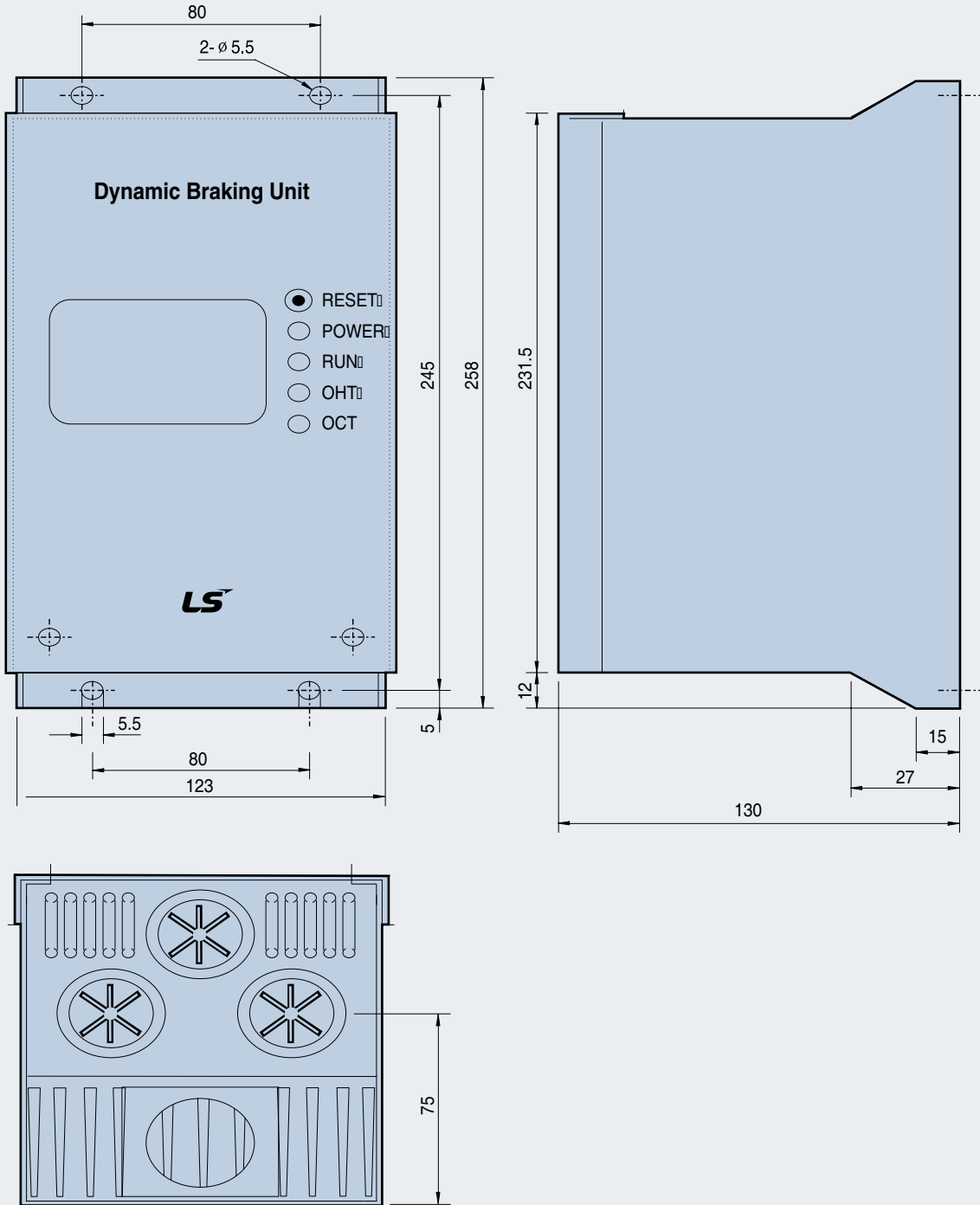

DB (Dynamic Braking) Unit

Group 3

(Unit: mm)

4-M5 Mounting

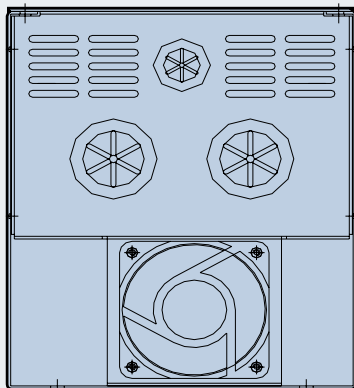
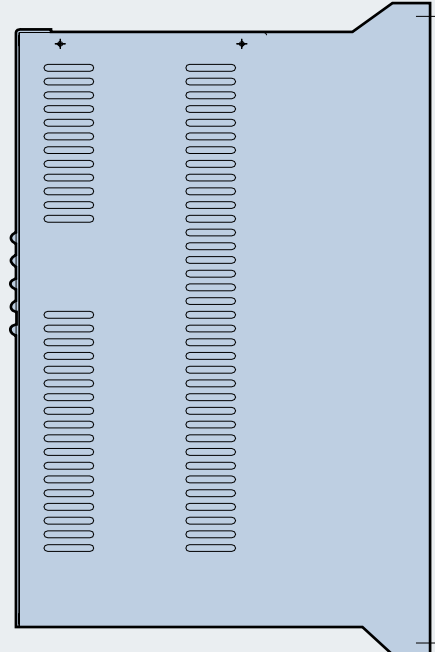
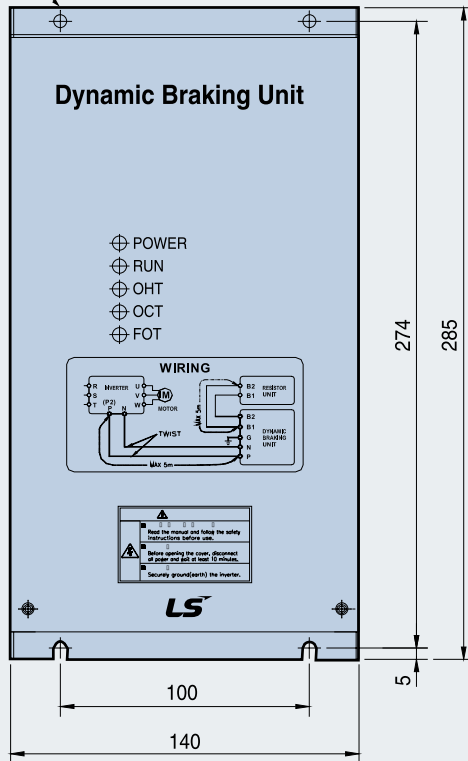

iP5A

External DB Resistor

iP5A do not have built-in DB resistor on power stack as factory installation. External DB Unit and Resistor (Optional) should be installed. See the following table for more details (ED: 5%, Continuous Braking Time: 15 sec). If Enable duty (%ED) is increased to 10%, use external DB resistor having twice Wattage rating.

Applied motor capacity (kW/HP)	Operating rate (ED/Continuous Braking Time)	100 % Braking Torque			150% Braking Torque			
		[ohm]	[W]	Type	[ohm]	[W]	Type	
200V	0.75/1	5%/15 sec	200	100	TYPE 1	150	150	TYPE 1
	1.5/2	5%/15 sec	100	200	TYPE 1	60	300	TYPE 1
	2.2/3	5%/15 sec	60	300	TYPE 1	50	400	TYPE 1
	3.7/5	5%/15 sec	40	500	TYPE 2	33	600	TYPE 2
	5.5/7.5	5%/15 sec	30	700	Type3	20	800	Type 3
	7.5/10	5%/15 sec	20	1000	Type 3	15	1200	Type 3
	11/15	5%/15 sec	15	1400	Type 3	10	2400	Type 3
	15/20	5%/15 sec	11	2000	Type 3	8	2400	Type 3
	18.5/25	5%/15 sec	9	2400	Type 3	5	3600	Type 3
	22/30	5%/15 sec	8	2800	Type 3	5	3600	Type 3
30/40	10%/6 sec	4.2	6400	-	-	-	-	
400V	0.75/1	5%/15 sec	900	100	TYPE 1	600	150	TYPE 1
	1.5/2	5%/15 sec	450	200	TYPE 1	300	300	TYPE 1
	2.2/3	5%/15 sec	300	300	TYPE 1	200	400	TYPE 1
	3.7/5	5%/15 sec	200	500	TYPE 2	130	600	TYPE 2
	5.5/7.5	5%/15 sec	120	700	Type 3	85	1000	Type 3
	7.5/10	5%/15 sec	90	1000	Type 3	60	1200	Type 3
	11/15	5%/15 sec	60	1400	Type 3	40	2000	Type 3
	15/20	5%/15 sec	45	2000	Type 3	30	2400	Type 3
	18.5/25	5%/15 sec	35	2400	Type 3	20	3600	Type 3
	22/30	5%/15 sec	30	2800	Type 3	20	3600	Type 3
	30/40	10%/6 sec	16.9	6400	-	-	-	-
	37/50	10%/6 sec	16.9	6400	-	-	-	-
	45/60	10%/6 sec	11.4	9600	-	-	-	-
	55/75	10%/6 sec	11.4	9600	-	-	-	-
75/100	10%/6 sec	8.4	12800	-	-	-	-	
90/125	10%/6 sec	8.4	12800	-	-	-	-	

Peripheral Device

MCCB (Molded Case Circuit Breaker) and MC (Magnetic Contactor)

Voltage	Capacity [kW]	Circuit Breaker (MCCB)				Leakage Breaker (ELCB)		Magnetic Contactor (MC)	
		Model	Rated Current [A]	Model	Rated Current [A]	Model	Rated Current [A]	Model	Rated Current [A]
3-Phase 200V	5.5	UTS150	50	ABS53c	50	EBS53c	50	MC-32a	32
	7.5		60	ABS63c	60	EBS63c	60	MC-40a	40
	11		100	ABS103c	100	EBS103c	100	MC-50a	55
	15	UTS250	125	ABS203c	125	EBS203c	125	MC-65a	65
	18.5		150		150		150	MC-100a	105
	22		175		175		175	MC-130a	130
30		225		225		225	MC-150a	150	
3-Phase 400V	5.5	UTE100	30	ABS33c	30	EBS33c	30	MC-22b	22
	7.5		30		30		30		22
	11	UTS150	50	ABS53c	50	EBS53c	50	MC-40a	40
	15		60	ABS63c	60	EBS63c	60	MC-50a	50
	18.5		60	ABS63c	60	EBS63c	60		50
	22		100	ABS103c	100	EBS103c	100	MC-65a	65
	30		125	ABS203c	125		125	125	MC-75a
	37	150	150		150	150	MC-100a	105	
	45	200	200		200	200	MC-130a	130	
	55	UTS250	250		250		250	MC-150a	150
	75	UTS400	300	ABS403c	300	EBS403c	300	MC-185a	185
	90		350		350		350	MC-225a	225
	110		400		400		400	MC-330a	330
	132	UTS600	500	ABS603c	500	EBS603c	500		400
	160		600		630		630	MC-400a	400
	220	UTS800	800	ABS803c	800	EBS803c	800	MC-630a	630
	280	UTS1200	1000	ABS1003b	1000	EBS1003c	1000		630
	315		1200	ABS1203b	1200	EBS1203c	1200	MC-800a	800
375	1400A	1400	1400A	1400	1400A	1400	900A	900	
450	1600A	1600	1600A	1600	1600A	1600	1000A	1000	
3-Phase 600V	5.5	UTE100	30	ABS33c	30	-		MC-22b	20
	7.5		30		30	-			20
	11	UTS150	50	ABS53c	50	-		MC-40a	32
	15		60	ABS63c	60	-		MC-50a	43
	18.5		60		60	-			43
	22		100	ABS103c	100	-		MC-65a	60
	30		100		100	-		MC-75a	64
	37	125	ABS203c		125	-		MC-100a	85
	45	150		150	-		MC-130a	90	
	55	UTS250		175	ABS203c	175	-		MC-150a
	75		250	250		-		MC-185a	180
	90	UTS400	300	ABS403c	300	-		MC-225a	200
110	400		400		-		MC-330a	280	

iP5A

AC Input Fuse

Voltage	Motor [kW]	Drive Model	AC Input Fuse [A]	AC Reactor		DC Reactor	
				[mH]	[A]	[mH]	[A]
200V Class	0.75	SV008iP5A-2	10	2.13	5.7	-	-
	1.5	SV015iP5A-2	15	1.2	10	-	-
	2.2	SV022iP5A-2	20	0.88	14	-	-
	3.7	SV037iP5A-2	30	0.56	20	-	-
	5.5	SV055iP5A-2	40	0.39	30	1.37	29
	7.5	SV075iP5A-2	60	0.28	40	1.05	38
	11	SV110iP5A-2	80	0.20	59	0.74	56
	15	SV150iP5A-2	100	0.15	75	0.57	71
	18.5	SV185iP5A-2	125	0.12	96	0.49	91
	22	SV220iP5A-2	150	0.10	112	0.42	107
400V Class	30	SV300iP5A-2	200	0.07	160	0.34	152
	0.75	SV008iP5A-4	10	8.63	2.8	-	-
	1.5	SV015iP5A-4	10	4.81	4.8	-	-
	2.2	SV022iP5A-4	10	3.23	7.5	-	-
	3.7	SV037iP5A-4	15	2.34	10	-	-
	5.5	SV055iP5A-4	20	1.22	15	5.34	14
	7.5	SV075iP5A-4	30	1.14	20	4.04	19
	11	SV110iP5A-4	40	0.81	30	2.76	29
	15	SV150iP5A-4	60	0.61	38	2.18	36
	18.5	SV185iP5A-4	70	0.45	50	1.79	48
	22	SV220iP5A-4	80	0.39	58	1.54	55
	30	SV300iP5A-4	100	0.287	80	1.191	76
	37	SV370iP5A-4	125	0.232	98	0.975	93
	45	SV450iP5A-4	150	0.195	118	0.886	112
	55	SV550iP5A-4	175	0.157	142	0.753	135
	75	SV750iP5A-4	250	0.122	196	0.436	187
	90	SV900iP5A-4	300	0.096	237	0.352	225
	110	SV1100iP5A-4	350	0.081	289	Built-in	
	132	SV1300iP5A-4	400	0.069	341	Built-in	
	160	SV1600iP5A-4	450	0.057	420	Built-in	
220	SV2200iP5A-4	700	0.042	558	Built-in		
280	SV2800iP5A-4	800	0.029	799	Built-in		
315	SV3150iP5A-4	900	0.029	799	0.090	836	
375	SV3750iP5A-4	1000	0.024	952	0.076	996	
450	SV4500iP5A-4	1200	0.024	952	0.064	1195	
600V Class	5.5	SV055iP5A-6	15	2.45	12	9.32	11
	7.5	SV075iP5A-6	20	1.80	16	6.27	15
	11	SV110iP5A-6	30	1.23	23	4.60	22
	15	SV150iP5A-6	40	0.900	32	3.82	30
	18.5	SV185iP5A-6	50	0.730	39	2.80	37
	22	SV220iP5A-6	60	0.614	47	2.27	44
	30	SV300iP5A-6	80	0.450	63	1.91	60
	37	SV370iP5A-6	100	0.365	78	1.40	75
	45	SV450iP5A-6	125	0.300	95	1.13	91
	55	SV550iP5A-6	150	0.245	116	0.933	111
75	SV750iP5A-6	175	0.180	159	0.763	151	
90	SV900iP5A-6	250	0.150	190	0.560	181	

iP5A

MEMO



MEMO



Safety Instructions

- For your safety, please read user's manual thoroughly before operating.
- Contact the nearest authorized service facility for examination, repair, or adjustment.
- Please contact qualified service technician when you need maintenance. Do not disassemble or repair by yourself!
- Any maintenance and inspection shall be performed by the personnel having expertise concerned.



www.lsis.com

■ Head Quarter

LS-ro 127(Hogye-dong) Dongan-gu, Anyang-si, Gyeonggi-Do, 14119, Korea
Tel: 82-2-2034-4620 mswoo@lsis.com
Tel: 82-2-2034-4907 hjchoid@lsis.com

■ Overseas Subsidiaries

- **LSIS(Dalian) Co., Ltd. (Dalian, China)**
Tel: 86-411-8730-7510 Fax: 86-411-8730-7560 E-Mail: dskim@lsis.com
- **LSIS(Wuxi) Co., Ltd. (Wuxi, China)**
Tel: 86-510-8534-6666-8005 Fax: 86-510-8534-4078 E-Mail: sojin@lsis.com
- **LS VINA Industrial Systems Co., Ltd. (Hanoi, Vietnam)**
Tel: 84-4-6275-8055 Fax: 84-4-3882-0220 E-Mail: hjchoid@lsis.com
- **LSIS Middle East FZE (Dubai, U.A.E.)**
Tel: 971-4-886-5360 Fax: 971-4-886-5361 E-Mail: shunlee@lsis.com
- **LSIS Europe B.V. (Amsterdam, Netherlands)**
Tel: 31-20-654-1420 Fax: 31-20-654-1429 E-Mail: europartner@lsis.com
- **LSIS Japan Co., Ltd. (Tokyo, Japan)**
Tel: 81-3-6268-8241 Fax: 81-3-6268-8240 E-Mail: jschuna@lsis.com
- **LSIS USA Inc. (Chicago, U.S.A.)**
Tel: 1-800-891-2941 Fax: 1-847-383-6543 E-Mail: sales.us@lsis.com

■ Overseas Branches

- **LSIS Shanghai Office (China)**
Tel: 86-21-5237-9977(609) Fax: 86-21-5237-7189 E-Mail: ygeo@lsis.com
- **LSIS Beijing Office (China)**
Tel: 86-10-5761-3127 Fax: 86-10-5761-3128 E-Mail: htroh@lsis.com
- **LSIS Guangzhou Office (China)**
Tel: 86-20-8326-6784 Fax: 86-20-8326-6287 E-Mail: sojhtroh@lsis.com
- **LSIS Qingdao Office (China)**
Tel: 86-532-8501-6058 Fax: 86-532-8501-6057 E-Mail: htroh@lsis.com
- **LSIS Chengdu Office (China)**
Tel: 86-28-8670-3200 Fax: 86-28-8670-3203 E-Mail: yangcf@lsis.com
- **LSIS ShenYang Office (China)**
Tel: 86-24-2321-9050 Fax: 86-24-8386-7210 E-Mail: yangcf@lsis.com
- **LSIS Jinan Office (China)**
Tel: 86-531-8699-7826 Fax: 86-531-8697-7628 E-Mail: yangcf@lsis.com
- **LSIS Co., Ltd. Tokyo Office (Japan)**
Tel: 81-3-6268-8241 Fax: 81-3-6268-8240 E-Mail: jschuna@lsis.com
- **LSIS Co., Ltd. Rep. Office (Vietnam)**
Tel: 84-8-3823-7890 E-Mail: sjbaik@lsis.com
- **LSIS Moscow Office (Russia)**
Tel: 7-499 682 6130 E-Mail: info@lsis-ru.com
- **LSIS Jakarta Office (Indonesia)**
Tel: 62-21-293-7614 E-Mail: dioh@lsis.com