



XDL/XML Series
XGT Servo System

High
Performance

Intelligent
control

Reliability

Convenience

Easy to use

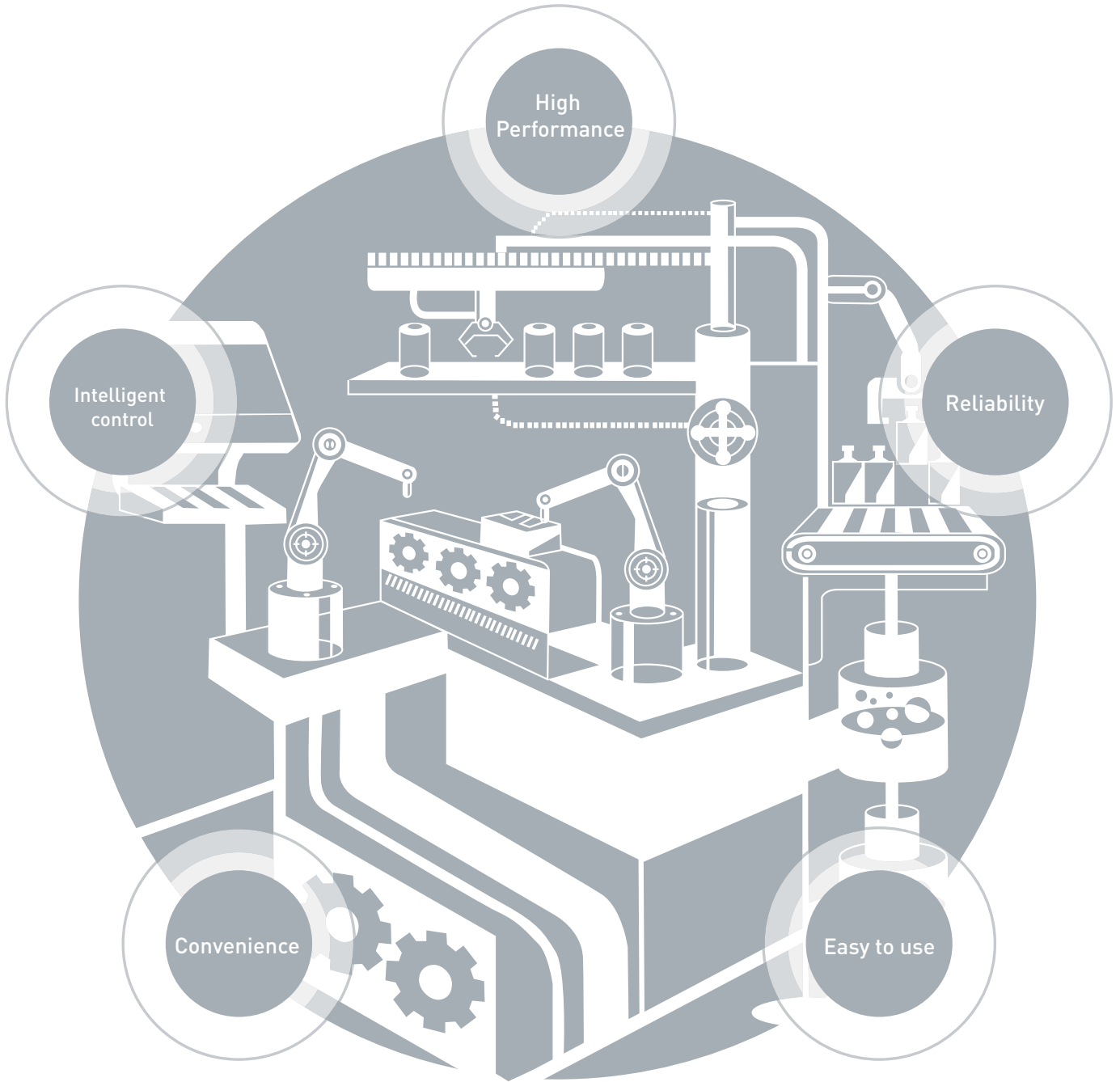

XGT Servo System **XDL/XML Series**



Features
4 ~ 13

Features

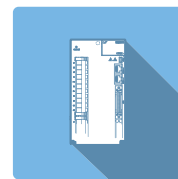

Servo Drive
14 ~ 57

Servo Drive



Servo Motor
58 ~ 99

Servo Motor

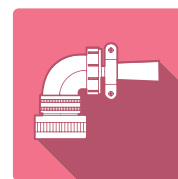

**Options and
Accessories**
100 ~ 118

Options and Accessories



Application
122 ~ 135

Application

User-oriented XDL/XML Series
LSIS XGT Servo systems complete
your optimal solution.



XDL /

Your motion systems visualize the perfect solution through the LS comprehensive product ranges for the optimal drives and applications. Its high-performance vector, precision and speed control are user-friendly and cost effective.



XML Series

It's Slim

Compact size with high capacity

Capacity	400W <i>(44% Down Size)</i>			1kW <i>(46% Down Size)</i>			3.5kW <i>(62% Down Size)</i>			
	Series	XDL	VS	Competitor	XDL	VS	Competitor	XDL	VS	Competitor
L [mm]	38	80	40	58	88	60	88	137	90	
W [mm]	169	187	168	169	210	168	169	256	168	
H [mm]	173	132	170	198	195	195	198	225	195	

38 mm

The Minimized Width to 38mm!!! (400W)



Reliability

Main capacitor quality improved

- Long-life type capacitor applied (2.5 times improvement)

Convenient DC reactor installable

- Power connection to DC-link
- Easier wiring and smaller size compared to 3-phase AC reactor
- Connection for DC input (PI, N)

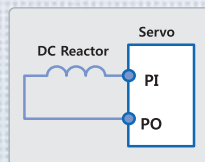

Stable turn-off function based on the detection of the control power turn-off

Upgraded protection function (II)

- Triple protection functions for power module : IPM fault, CL detecting, over current detecting with S/W
- Main power mis-wiring detecting function : Selecting 3 phase or single phase, and alarm or warning is available
- Protecting overheating with thermal sensor in the drive and motor
- Alarm code grouping and exclusive output contacts (AL00, AL01, AL02)
- Warning function (digital output, warning output) : Mis-wiring of power, low voltage for encoder battery, over speed command, over torque command, over load, mis-matched motor and drive

52%

Compared with VS Drive
Max 52% Slim



1kW



3.5kW

5%

Compared with competitor's Drive
Max 5% Slim

Upgraded protection function (III)

- Detecting function for accumulated over load of regenerative resistor
 - : Protect algorithm is provided with embedded resistor characteristic
 - : Protection by capacity (P0-11) and resistance (P0-10)
 - : Providing de-rating factor for radiant heat
- Available continuous overload capacity setting as followed operating condition
 - : Protect with separated overload table at stall & operation
 - : Set overload check level (P0-12)
 - : Setting warning signal output level is available (P0-13)

CE, RoHS certificated

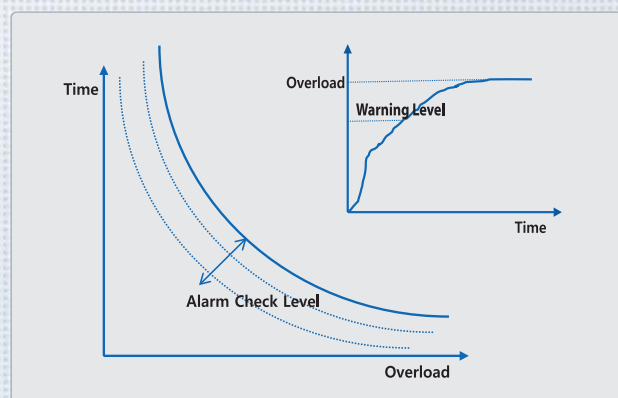

Easy to USE

Reliable partner with global standard performance and easy control by user-centric environment



Easy gain tuning with automatic inertia estimating function

- Quick & Accurate Inertia Estimating
- On-Line Tuning: L7NH, L7P
- Off-Line Tuning: L7N, L7S
- Parameter for Estimation (Speed & Distance)

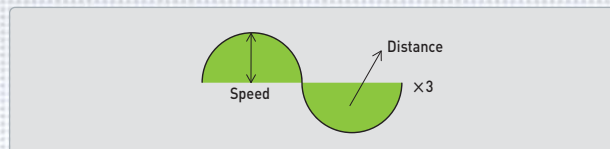

Encoder with bi-directional high speed serial communication

- Automatic Identification (Motor ID / Encoder pulse)
- BiSS protocol
- Easy wiring (15 encoder wires → 7 encoder wires) and anti-external noise



Sufficient input/output contacts and various functions

- L7S: Digital input contacts: 10, output contacts: 8 / Analog input contacts: 2 and output contacts: 2
- L7N: Digital input contacts: 6, output contacts: 4 / Analog input contacts: 2 and output contacts: 2
- L7NH: Digital input contacts: 8, output contacts: 4 / Analog input contacts: 1 and output contacts: 2
- L7P: Digital input contacts: 16, output contacts: 8 / Analog input contacts: 2 and output contacts: 2
- PEGASUS: Digital input contacts: 4, output contacts: 2 / Analog input contacts: 1 and output contacts: 1
- Flexible assignment of input/output signals by parameters and contact setting based on the input/output contact type (N.O / N.C contacts)

Using the rotary switch to configure the drive node address [L7NH, L7P, and PEGASUS]

- Using the rotary switch to configure the drive node address conveniently
- L7NH: 0-99, L7P: 0-31, PEGASUS: 0-15

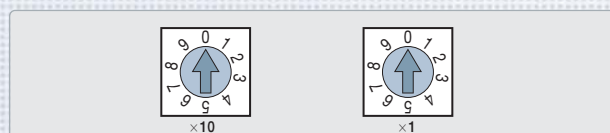

Plug-in type power connector

- Expanded to 100 W - 3.5 kW for improved wiring convenience



Various homing functions [L7NH, L7P, and PEGASUS]

- The drive provides the homing function.
- You can specify the speed, acceleration, offset, and homing method.

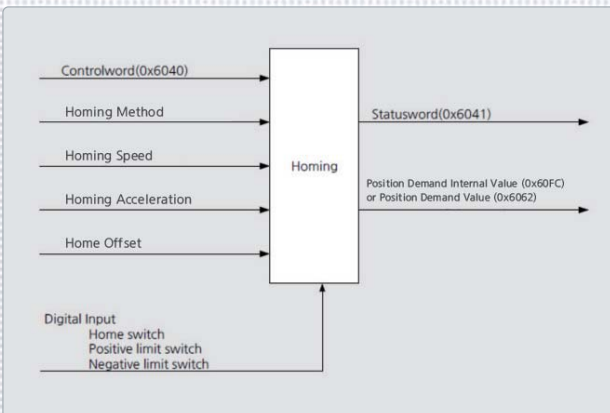

Easy firmware upgrade [L7NH, L7P, and PEGASUS]

- Supporting the USB OTG function to allow firmware download with a USB memory
- Useful where space is limited or environmentally unfavorable



Built-in regenerative braking resistance in the drive

- Drive installed inside to improve user convenience (100 W - 3.5 kW)
- Providing the connection for external installation
- Enhanced protection algorithm



Features

XGT Servo series with high speed, incredible performance,
smart and convenience. It's time to check value of XDL/XML series

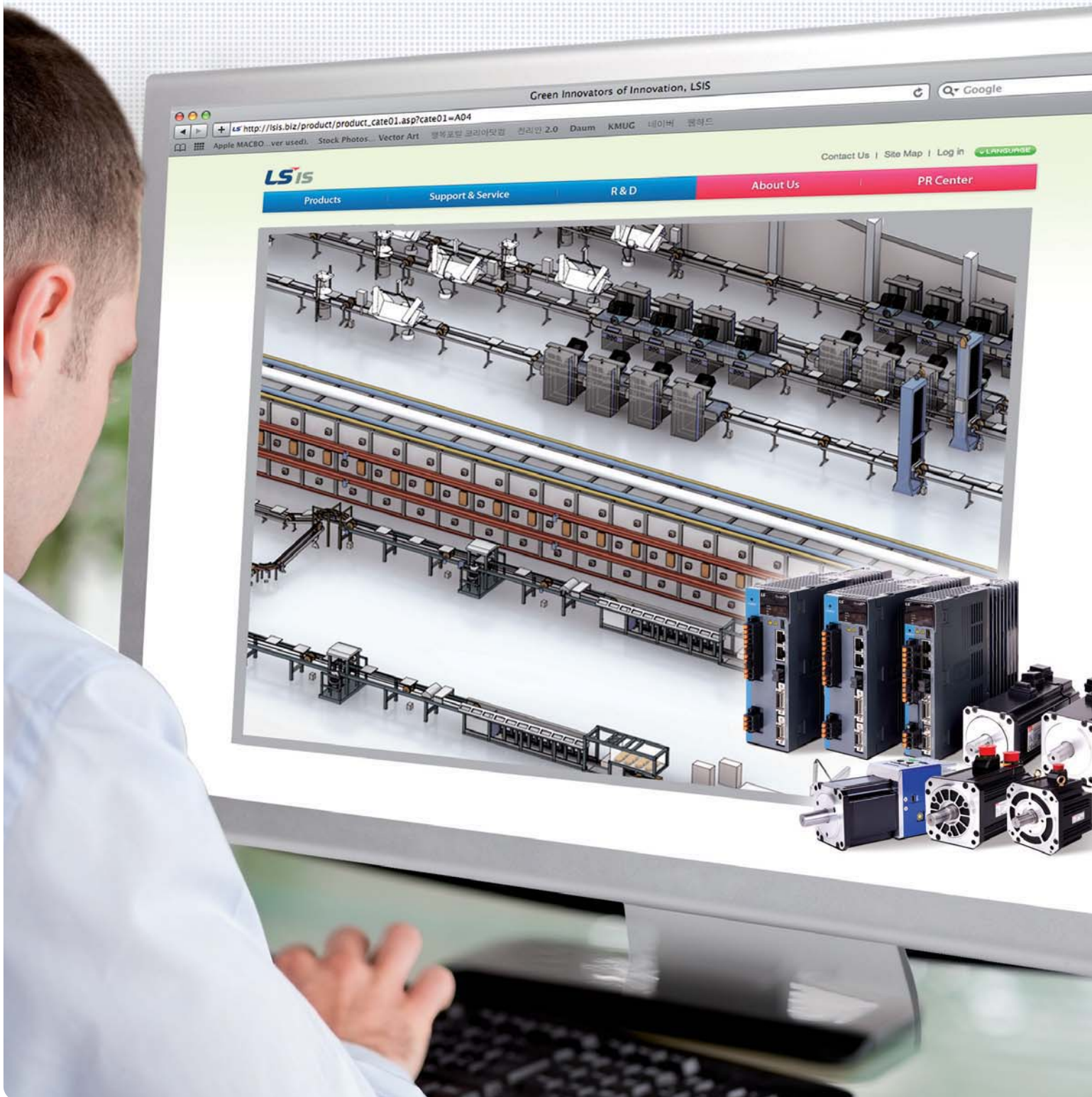

High Performance

Serial encoder of high resolution (16 bit - 21 bit)

- Stability improved during precision position control and low-speed operation

Stable low-speed properties based on precise speed measurement

- Stable speed measurement at low speed

Calculation speed improved [L7NH, L7P, and PEGASUS]

- FPU (Floating Point Unit) for reliable precision calculation
- 16 kHz switching frequency for precision current control
- 32 bit operation for increased synchronous command processing rate (MIPS)

Dedicated PC program

- L7S, and L7N: LIVE-I.C.E / L7NH, L7P, and PEGASUS: Drive CM
- PC program for shortened equipment tuning time and debugging
- Monitoring for speed, torque, current feedback, position values and positional error values and alarm occurrence time

Intelligent Control

Notch filter for resonance suppression

- 4-step notch filter
- 2-step vibration suppression filter at the load position
- FFT function for real-time frequency analysis

Various gain switching modes for improved control performance

- P/PI auto-switching function to reduce overshooting during acceleration/deceleration
- Various Gain1 ↔ Gain2 switching modes

Various dynamic brake control modes

- Configuring the operation mode at stop and after stop

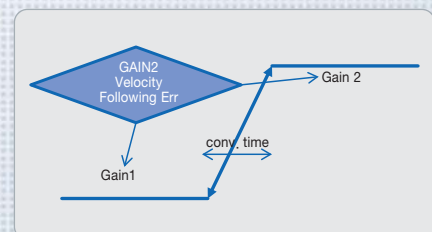
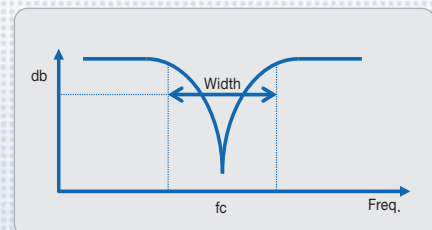

Convenience

Providing various functions- backup, network diagnosis, monitoring and built-in functions focused on improving efficiency



High Performance

- High speed, Real-time capability and Synchronization mechanism

Open Network

- Over 1600 worldwide members

Cost Effective

- Standard Ethernet Cabling + Connectors, Less implementation efforts for master and slave

Easy to Use

- Versatile topology and Diagnostics

XDL Drive with Built-in EtherCAT Interface

- 100BASE-TX(100Mbps) Ethernet based real-time communication
- Support CiA402(IEC61800-7) drive profile
- Interoperability
- Max. 100m between nodes
- Precise synchronization mechanism (1us)
- Freely settable process data length and mapping
- Four status indication LEDs (L/A0, L/A1, RUN, ERR)
- Standard RJ45 connector and cabling(CAT5)
- Support various homing modes
- Support Full-Closed control (Being developed)

Various operation modes

- L7N: Using the EtherCAT communication to support Cyclic (P/S/T) and Profile (P/S/T) modes
- L7NH and PEGASUS: Using the EtherCAT communication to support Cyclic & Profile (P/S/T) modes, EOE, COE, and FOE

Safe torque off function

- Torque-off forced by hardware signals without involvement of the drive CPU and FPGA (ASIC); international standards adopted (IEC61508)

High speed position capture function

- Touch probe function(PROBE1, PROBE2)

Adjustment function linked with XGT series from LSIS

- Inertia detection, position/speed gain manual adjustment, gain switching setup, etc.

Have conformity of EtherCAT device

- In-house test using CTT(Conformance Test Tool)

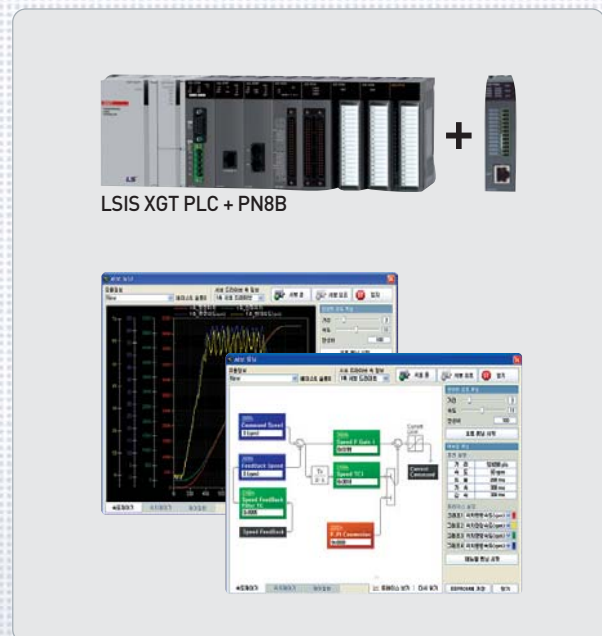
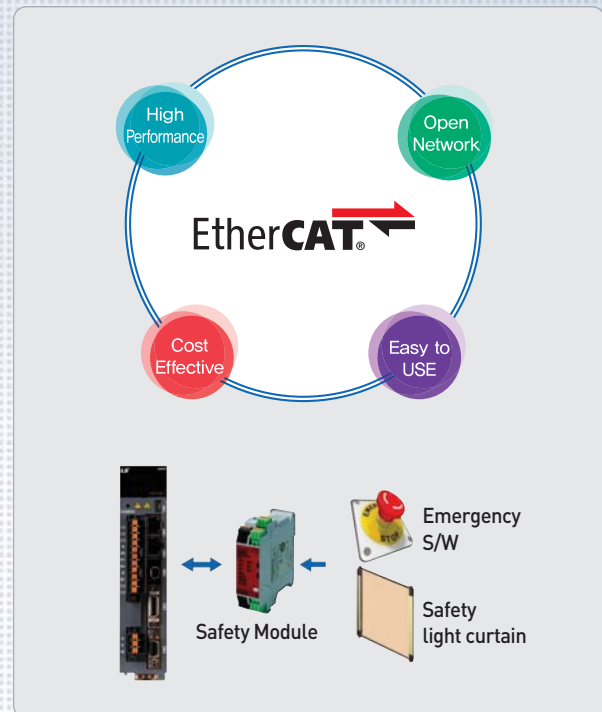

Provide gain tuning tools and commissioning packages

- Automatic inertia tuning and PI gains
- Gain conversion setting
- Manual fine gain tuning tool
- Object save and initialization function
- Alarm history function(recently issued 20 alarm codes)

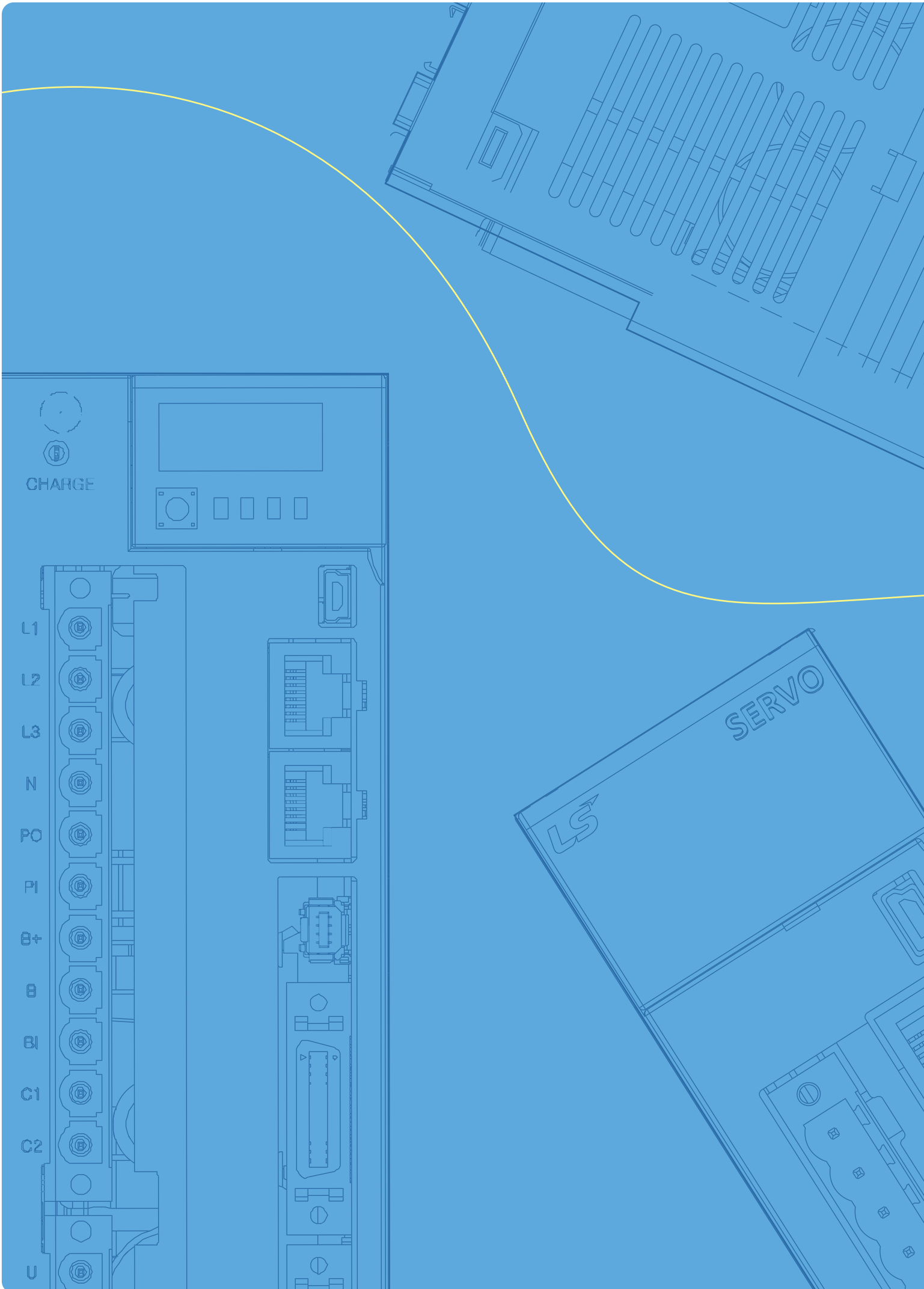

CHARGE

L1

L2

L3

N

PO

PI

B+

B

BI

C1

C2

U

SERVO

LS

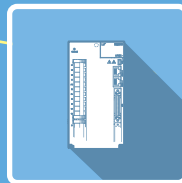

Servo Drive

Contents

L7S Series

Pulse, Analog Command Type ----- 16

L7N Series

EtherCAT Communication Type ----- 28

L7NH Series

All-in-One EtherCAT Communication Type ----- 34

L7P Series

Indexer Function Type ----- 46

XIP(PEGASUS) Series

Integrated Servo System Type ----- 52

XDL-L7S Series



Servo Drive Designation

Model Name	Communication	Input Power Supply	Capacity	Encoder Type	Option
XDL Series	S : Standard I/O Type	A : 200VAC B : 400VAC	001 : 100W 002 : 200W 004 : 400W 008 : 750W 010 : 1.0kW 020 : 2.0kW 035 : 3.5kW 050 : 5.0kW 075 : 7.5kW 150 : 15.0kW	A : Quadrature (Pulse Type) B : Serial (Communication Type)	Exclusive Option Code

* Range

- 200V : 0.1kW~5.0kW
- 400V : 1.0kW~15kW

Pulse, Analog Command Type **XDL-L7S**

Easy to USE

- Easy Gain Tuning with Automatic Inertia Estimating Function
- Easy Setting Built-in Panel Operator
- Many I/O Contacts and Various Functions
[Digital Input: 10 contacts, Digital Output:8 contacts / Analog input, output : 2 contacts]

Reliability for Protection Function

- CE, RoHS Certificated
- Drive Protection Function and Warn unction

High Response for Precision Control

- High Resolutions Serial type Encoder(19Bit, BiSS)
- Improved Speed Response(≒1Khz) Frequency

- 1 Operation keys (Mode, Up, Down, Set)
- 2 Charge Lamp
- 3 Main Power Connector (L1, L2, L3)
- 4 DC Reactor Connector(PO, PI)
 - Short-Circuit when not used
- 5 Regenerative resistance connector (B+, B, BI)
 - Short-Circuit B, BI terminals when standard type
 - Use B+, B terminals when using external resistor
- 6 Control Power Connector (C1, C2)
- 7 Front Cover
- 8 Motor Power Cable Connector (U, V, W)
- 9 Heat Sink
- 10 Display
- 11 CN5 : USB Connector
- 12 CN4 : RS-422 Communication Connector
- 13 CN3 : RS-422 Communication Connector
- 14 CN1 : Control Signal Connector
- 15 CN2 : Encoder Signal Connector
- 16 Ground

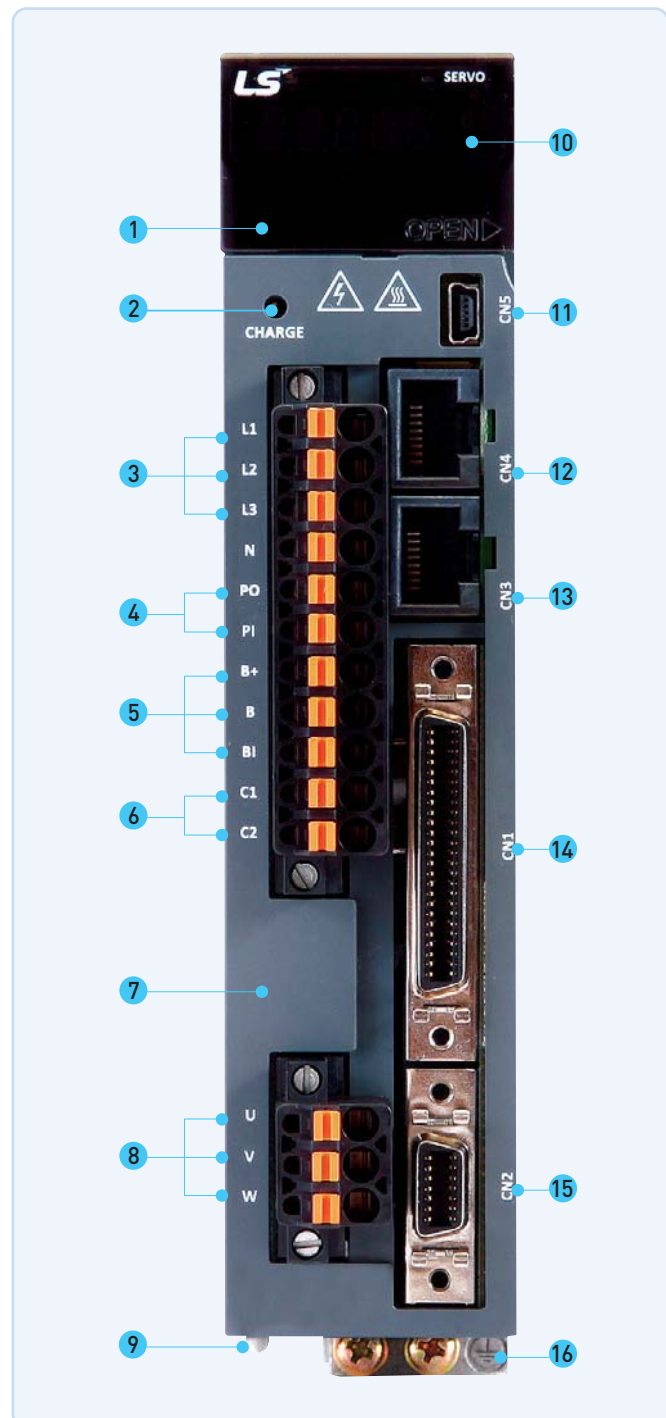

XDL-L7SA Incremental Type

Rated Speed (rpm)	Maximum Speed (rpm)	Flange Size	Applicable Motor	Applicable Drive	Standard Encoder Type	Encoder Cable	Power Cable													
					Quadrature Type	INC	For power	Power + Brake	Brake											
3,000	5,000	□40	SAR3A	L7SA001A	* 2,048P/R	XLCS-E□□□AS	XLCS-P□□□GS		XLCS-P□□□KB											
		□40	SAR5A	L7SA001A																
		□40	SA01A	L7SA001A																
		□40	SA015A	L7SA002A																
		□60	SB01A	L7SA002A																
		□60	SB02A	L7SA002A																
		□60	SB04A	L7SA004A																
		□80	SC04A	L7SA004A																
		□80	SC06A	L7SA008A																
		□80	SC08A	L7SA008A																
		□80	SC10A	L7SA010A																
		□130	SE09A	L7SA008A																
		□130	SE15A	L7SA020A																
		□130	SE22A	L7SA020A																
		□130	SE30A	L7SA050A																
		2,000	3,000	□80						SC03D	L7SA004A	* 3,000P/R	XLCS-E□□□AS	XLCS-P□□□GS		XLCS-P□□□KB				
□80	SC05D			L7SA008A																
□80	SC06D			L7SA008A																
□80	SC07D			L7SA008A																
□130	SE06D			L7SA008A																
□130	SE11D			L7SA010A																
□130	SE16D			L7SA020A																
□130	SE22D			L7SA020A																
□180	SF22D			L7SA020A																
□180	LF35D			L7SA035A																
□180	SF55D			L7SA050A																
1,500	3,000			□220	SG22D	L7SA020A	* 3,000P/R	XLCS-E□□□BS	XLCS-P□□□HS	XLCS-P□□□NB	XLCS-P□□□SB									
				□220	LG35D	L7SA035A														
				□220	SG55D	L7SA050A														
				□130	SE05G	L7SA008A														
				□130	SE09G	L7SA010A														
		□130	SE13G	L7SA020A																
		□130	SE17G	L7SA020A																
		□180	SF20G	L7SA035A																
	2,700	3,000	□180	LF30G	L7SA035A	* 3,000P/R						XLCS-E□□□BS	XLCS-P□□□IS	XLCS-P□□□PB	XLCS-P□□□SB					
			□180	SF44G	L7SA050A															
			□220	SG20G	L7SA020A															
			□220	LG30G	L7SA035A															
			□220	SG44G	L7SA050A															
			□130	SE03M	L7SA004A															
			□130	SE06M	L7SA008A															
			□130	SE09M	L7SA010A															
1,000	2,000	□130	SE12M	L7SA020A	* 3,000P/R		XLCS-E□□□BS	XLCS-P□□□IS	XLCS-P□□□PB	XLCS-P□□□SB										
		□180	SF12M	L7SA020A																
		□180	SF20M	L7SA035A																
		□180	LF30M	L7SA035A																
		□180	SF44M	L7SA050A																
		□220	SG12M	L7SA020A																
	1,700	2,000	□220	SG20M							L7SA035A					* 3,000P/R	XLCS-E□□□BS	XLCS-P□□□IS	XLCS-P□□□PB	XLCS-P□□□SB
			□220	SG30M							L7SA035A									
			□220	SG44M		L7SA050A														
			□60	HB01A		L7SA002A														
			□60	HB02A		L7SA002A														
			□60	HB04A		L7SA004A														
	3,000	3,500	□130	HE09A		L7SA008A					* 1,048P/R	XLCS-E□□□AS	XLCS-P□□□GS							
			□130	HE15A		L7SA020A														
			□130	HE30A		L7SA050A														
			□130	HE09A		L7SA008A														
□130			HE15A	L7SA020A																
□130			HE30A	L7SA050A																
3,000	3,500	□130	HE09A	L7SA008A	* 2,048P/R	XLCS-E□□□BS	XLCS-P□□□HS													
		□130	HE15A	L7SA020A																
		□130	HE30A	L7SA050A																
		□130	HE09A	L7SA008A																
		□130	HE15A	L7SA020A																
		□130	HE30A	L7SA050A																

XDL-L7SA Serial Type

Rated Speed (rpm)	Maximum Speed (rpm)	Flange Size	Applicable Motor	Applicable Drive	Standard Encoder Type	Encoder Cable		Power Cable		
					Serial Type	Serial	Abs	For power	Power + Brake	Brake
3,000	5,000	□40	FALR5A	L7SA001B	* 18Bit Serial / M-Turn Abs	XLCS-E□□□ES	XLCS-E□□□ES1	XLCS-P□□□LS		XLCS-P□□□QS
		□40	FAL01A	L7SA001B						
		□40	FAL015A	L7SA002B						
		□60	FBL01A	L7SA001B						
		□60	FBL02A	L7SA002B						
		□60	FBL04A	L7SA004B						
		□80	FCL04A	L7SA004B						
		□80	FCL06A	L7SA008B						
		□80	FCL08A	L7SA008B						
		□80	FCL10A	L7SA010B						
		□60	FB01A	L7SA001B						
		□60	FB02A	L7SA002B						
		□60	FB04A	L7SA004B						
		□80	FC04A	L7SA004B						
		□80	FC06A	L7SA008B						
		□80	FC08A	L7SA008B						
		□80	FC10A	L7SA010B						
		□130	FE09A	L7SA010B						
		□130	FE15A	L7SA020B						
		□130	FE22A	L7SA020B						
□130	FE30A	L7SA035B								
□180	FF30A	L7SA035B								
□180	FF50A	L7SA050B								
2,000	3,000	□80	FCL03D	L7SA004B	* 19Bit Serial / M-Turn Abs	XLCS-E□□□ES	XLCS-E□□□ES1	XLCS-P□□□LS		XLCS-P□□□QS
		□80	FCL05D	L7SA008B						
		□80	FCL06D	L7SA008B						
		□80	FCL07D	L7SA008B						
		□80	FC03D	L7SA004B						
		□80	FC05D	L7SA008B						
		□80	FC06D	L7SA008B						
		□80	FC07D	L7SA008B						
		□130	FE06D	L7SA008B						
		□130	FE11D	L7SA010B						
		□130	FE16D	L7SA020B						
		□130	FE22D	L7SA020B						
		□180	FF22D	L7SA020B						
		□180	FF35D	L7SA035B						
		□180	FF55D	L7SA050B						
		3,000	□220	FG22D				L7SA020B		
2,700	□220	FG35D	L7SA035B							
3,000	□220	FG55D	L7SA050B							
1,500	3,000	□130	FE05G	L7SA008B	XLCS-E□□□DS	XLCS-E□□□DS1	XLCS-P□□□HS	XLCS-P□□□NB		
		□130	FE09G	L7SA010B						
		□130	FE13G	L7SA020B						
		□130	FE17G	L7SA020B						
	□180	FF20G	L7SA020B							
	2,700	□180	FF30G	L7SA035B						
	3,000	□180	FF44G	L7SA050B						
	3,000	□220	FG20G	L7SA020B						
2,700	□220	FG30G	L7SA035B							
3,000	□220	FG44G	L7SA050B							
1,000	2,000	□130	FE03M	L7SA004B	XLCS-E□□□DS	XLCS-E□□□DS1	XLCS-P□□□HS	XLCS-P□□□NB		
		□130	FE06M	L7SA008B						
		□130	FE09M	L7SA010B						
		□130	FE12M	L7SA020B						
		□180	FF12M	L7SA020B						
	□180	FF20M	L7SA020B							
	1,700	□180	FF30M	L7SA035B						
	2,000	□180	FF44M	L7SA050B						
		□220	FG12M	L7SA020B						
		□220	FG20M	L7SA020B						
1,700		□220	FG30M	L7SA035B						
2,000		□220	FG44M	L7SA050B						

Servo Drive

XDL-L7SB Serial Type

Rated Speed (rpm)	Maximum Speed (rpm)	Flange Size	Applicable Motor	Applicable Drive	Standard Encoder Type	Encoder Cable		Power Cable			
					Serial Type	Serial	Abs	For power	Power + Brake	Brake	
3,000	5,000	□ 130	FEP09A	L7SB010B	* 19Bit Serial/ M-Turn Abs	XLCS- E□□□DS	XLCS- E□□□DS1	XLCS- P□□□HS	XLCS- P□□□NB		
		□ 130	FEP15A	L7SB020B							
		□ 130	FEP22A	L7SB035B							
		□ 130	FEP30A	L7SB035B							
		□ 180	FFP30A	L7SB035B							
		□ 180	FFP50A	L7SB050B							
2,000	3,000	□ 130	FEP06D	L7SB010B							
		□ 130	FEP11D	L7SB010B							
		□ 130	FEP16D	L7SB020B							
		□ 130	FEP22D	L7SB020B							
		□ 180	FFP22D	L7SB020B							
		□ 180	FFP35D	L7SB035B							
	2,500	3,000	□ 180	FFP55D							L7SB050B
			□ 180	FFP75D							L7SB075B
			□ 220	FGP22D							L7SB020B
	1,500	3,000	□ 220	FGP35D							L7SB035B
			□ 220	FGP55D							L7SB050B
			□ 220	FGP75D							L7SB075B
□ 220			FGP110D	L7SB150B							
2,000		3,000	□ 130	FEP05G							L7SB010B
			□ 130	FEP09G							L7SB010B
	□ 130		FEP13G	L7SB020B							
	□ 130		FEP17G	L7SB020B							
	2,700	3,000	□ 180	FFP20G							L7SB020B
			□ 180	FFP30G	L7SB035B						
			□ 180	FFP44G	L7SB050B						
			□ 180	FFP60G	L7SB075B						
			□ 180	FFP75G	L7SB075B						
			□ 220	FGP20G	L7SB020B						
2,000	3,000	□ 220	FGP30G	L7SB035B							
		□ 220	FGP44G	L7SB050B							
		□ 220	FGP60G	L7SB075B							
		□ 220	FGP85G	L7SB150B							
		□ 220	FGP110G	L7SB150B							
		□ 220	FGP150G	L7SB150B							
1,000	2,000	□ 130	FEP03M	L7SB010B							
		□ 130	FEP06M	L7SB010B							
		□ 130	FEP09M	L7SB010B							
		□ 130	FEP12M	L7SB020B							
		□ 180	FFP12M	L7SB020B							
		□ 180	FFP20M	L7SB020B							
	1,700	2,000	□ 180	FFP30M	L7SB035B						
			□ 180	FFP44M	L7SB050B						
			□ 220	FGP12M	L7SB020B						
			□ 220	FGP20M	L7SB020B						
			□ 220	FGP30M	L7SB050B						
			□ 220	FGP44M	L7SB050B						
1,000	2,000	□ 220	FGP60M	L7SB075B							
		□ 220	FGP12M	L7SB020B							
		□ 220	FGP20M	L7SB020B							
		□ 220	FGP30M	L7SB050B							
		□ 220	FGP44M	L7SB050B							
		□ 220	FGP60M	L7SB075B							

XDL-L7SA Drive

Item		Type Name	XDL-L7SA001 □	XDL-L7SA002 □	XDL-L7SA004 □	XDL-L7SA008 □	XDL-L7SA010 □	XDL-L7SA020 □	XDL-L7SA035 □	XDL-L7SA050 □	
Input Power	Main Power Supply	3 Phase AC200 ~ 230[V](-15 ~ +10[%]), 50 ~ 60[Hz]									
	Control Power Supply	Single Phase AC200 ~ 230[V](-15 ~ +10[%]), 50 ~ 60[Hz]									
Rated Current[A]		1.4	1.7	3.0	5.2	6.75	13.5	16.7	32		
Peak Current[A]		4.2	5.1	9.0	15.6	20.25	40.5	50.1	96		
Encoder Type		Quad. Type Incremental Line Driver Max 6000 [P/R] Serial Type 19Bit									
Control Performance	Speed Control	Speed Control Range	Maximum 1: 5000								
		Frequency Response	Maximum 1 [kHz] or above (When using 19bit Serial Encoder)								
		Speed Command	DC -10 [V]~+10 [V] (Reverse rotation in case of negative voltage)								
		Accel/Decel Time	Straight or S-curve acceleration/deceleration (0-10,000 [ms], possible to be set by one [ms] unit)								
		Speed Variation Ratio	±0.01 [%] or lower [when load changes between 0 and 100%] ±0.1[%] or lower [temperature 25 ±10°C]								
	Position Control	Input Frequency	1[Mpps], Line Driver / 200[kpps], Open Collector								
		Input Pulse Type	Symbol + Pulse Series, CW+CCW, A/B Phase								
		Electric Gear Ratio	Four digital gear ratios can be set, selected and tuned.								
	Torque Control	Torque Command	DC-10~+10 [V] (Reverse direction torque in case of negative voltage)								
		Speed Limit	DC 0~10 [V], internal speed command within ±1[%]								
Repetition accuracy		Within ±1[%]									
Input/Output Signal	Analog Input	Input Range	DC -10 ~ 10[V]								
		Resolution	12[bit]								
	Analog Output	Output Range	DC -10 ~ 10[V]								
		Resolution	12[bit]								
	Digital Input	Total 10 Input Channels(assignment available) SVON, SPD1, SPD2, SPD3, ALMRST, DIR, CCWLIM, CWLIM, EMG, STOP, EGEAR1, EGEAR2, PCON, GAIN2, P_CLR, T_LMT, MODE, ABS_RQ, ZCLAMP Above 19 functions can be used selectively for assignment Signal can be set as positive logic or negative logic									
	Digital Output	Total 5 Channels(assignment available), 3 Channels(set as alarm code) ALARM, READY, ZSPD, BRAKE, INPOS, TLMT, VLMT, INSPD, WARN Above 9 outputs can be used selectively for assignment Signal can be set as positive logic or negative logic									
Communication	RS-422	Accessible to PC software and the RS422 server									
	USB	Status monitoring, JOG operation, parameter upload/download are available with PC Software									
Encoder		Serial BiSS encoder and quadrature encoder supported									
Encoder Output Type		Random pre-scale output through FPGA (maximum 6.4 Mpps)									
Built-in functions	Dynamic Braking	Standard built-in (activated when the servo alarm goes off or when the servo is off)									
	Regenerative Braking	Both default built-in and external installation possible									
	Display	Seven segments (5 DIGIT)									
	Setting Function	Loader [SET, MODE, UP, and [DOWN] keys]									
	Additional Function	Auto gain tuning, phase Z detection, manual JOG operation, program JOG operation, automatic analog input calibration									
	Protective Function	Overcurrent, overload, overvoltage, insufficient voltage, main power input problem, control power input problem, overspeed, motor cable, overheat(power module overheat, abnormal drive operation's temp), encoder problem, over-regenerative, sensor problem, communication problem									
Environment	Temperature	0 ~ 50[°C]									
	Humidity	Below 90[%]RH(avoid dew-condensation)									
	Environment	Indoor, Avoid corrosive, inflammable gas or liquid, and electrically conductive dust.									

XDL-L7SB Drive

Item		Type Name	XDL-L7SB010 □	XDL-L7SB020 □	XDL-L7SB035 □	XDL-L7SB050 □	XDL-L7SB075 □	XDL-L7SB150 □
Input Power	Main Power Supply		3 Phase AC380 ~ 480[V](-15 ~ +10[%]), 50 ~ 60[Hz]					
	Control Power Supply		Single Phase AC380 ~ 480[V](-15 ~ +10[%]), 50 ~ 60[Hz]					
Rated Current[A]			3.7	8	10.1	17.5	22.8	39
Peak Current[A]			11.1	24	30.3	52.5	57	97.5
Encoder Type			Quad. Type Incremental Line Driver Max 6000 [P/R] Serial Type 19Bit					
Control Performance	Speed Control	Speed Control Range	Maximum 1: 5000					
		Frequency Response	Maximum 1 [kHz] or above (when the 19-bit serial encoder is applied)					
		Speed Command	DC -10 [V]~+10 [V] (Reverse rotation in case of negative voltage)					
		Accel/Decel Time	Straight or S-curve acceleration/deceleration (0-10,000 [ms], possible to be set by one [ms] unit)					
		Speed Variation Ratio	±0.01 [%] or lower [when load changes between 0 and 100%], ±0.1[%] or lower [temperature 25 ±10°C]					
	Position Control	Input Frequency	1[Mpps], Line Driver / 200[kpps], Open Collector					
		Input Pulse Type	Symbol + pulse series, CW+CCW, A/B phase					
		Electric Gear Ratio	Four digital gear ratios can be set, selected and tuned.					
	Torque Control	Torque Command	DC -10~+10 [V] (Reverse direction torque in case of negative voltage)					
		Speed Limit	DC 0~10 [V], internal speed command within ±1[%]					
		Repetition accuracy	Within ±1[%]					
	Input/Output Signal	Analog Input	Input Range	DC 0 ~ 10[V]				
Resolution			12[bit]					
Analog Output		Output Range	DC 0 ~ 10[V]					
		Resolution	12[bit]					
Digital Input		A total of 10 input channels (allocable) SVON, SPD1, SPD2, SPD3, ALMRST, DIR, CCWLIM, CWLIM, EMG, STOP, EGEAR1, EGEAR2, PCON, GAIN2, P_CLR, T_LMT, MODE, ABS_RQ, ZCLAMP You can selectively allocate a total of 19 functions. You can set the positive/negative logic of the selected signal.						
Digital Output		A total of 5 channels (allocable), 3 channels (fixed with alarm codes) ALARM, READY, ZSPD, BRAKE, INPOS, TLMT, VLMT, INSPD, WARN You can selectively allocate a total of nine kinds of output. You can set the positive/negative logic of the selected signal.						
Communication	RS-422	Accessible to PC software and the RS422 server						
	USB	Status monitoring through PC software, JOG operation, and parameter uploading/downloading are possible.						
Encoder			Serial BiSS encoder and quadrature encoder supported					
Encoder Output Type			Random pre-scale output through FPGA (maximum 6.4 Mpps)					
Built-in functions	Dynamic Braking	Standard built-in (activated when the servo alarm goes off or when the servo is off)						
	Regenerative Braking	Both default built-in and external installation possible						
	Display	Seven segments (5 DIGIT)						
	Setting Function	Loader (SET, MODE, UP, and [DOWN] keys)						
	Additional Function	Auto gain tuning, phase Z detection, manual JOG operation, program JOG operation, automatic analog input calibration						
	Protective Function	Overcurrent, overload, overvoltage, voltage lack, main power input error, control power input error, overspeed, motor cable, heating error (power module heating, drive temperature error), encoder error, excessive regeneration, sensor error, communication error						
Environment	Temperature	0 ~ 50[°C]						
	Humidity	90[%] RH or lower (no condensation)						
	Environment	Indoors, a place free from corrosive gas or combustible gas, or a place without liquid or conductive dust.						

External Dimensions

XDL-L7SA001 □ ~ XDL-L7SA004 □ [Weight 1.2kg]

*Unit [mm]

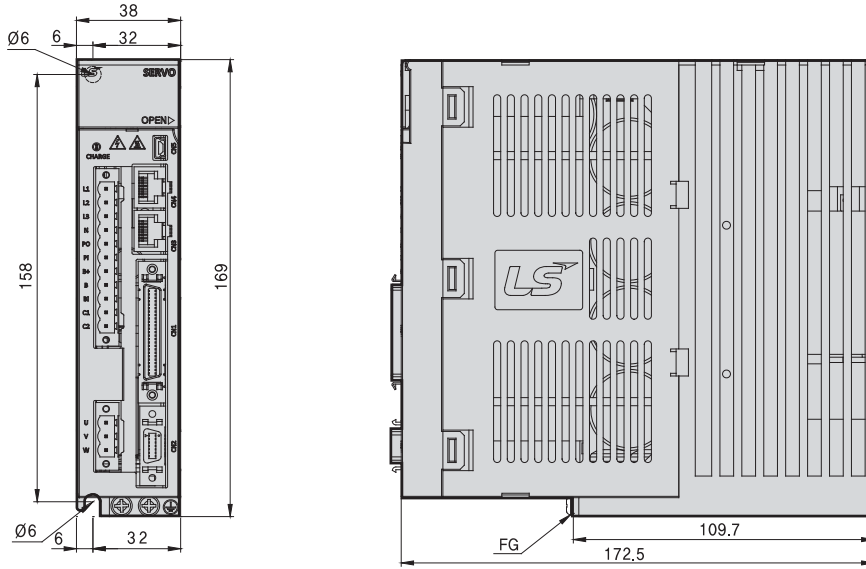

XDL-L7SA008 □ ~ XDL-L7SA010 □ [Weight : 1.5kg(Fan-Cooling included)]

*Unit [mm]

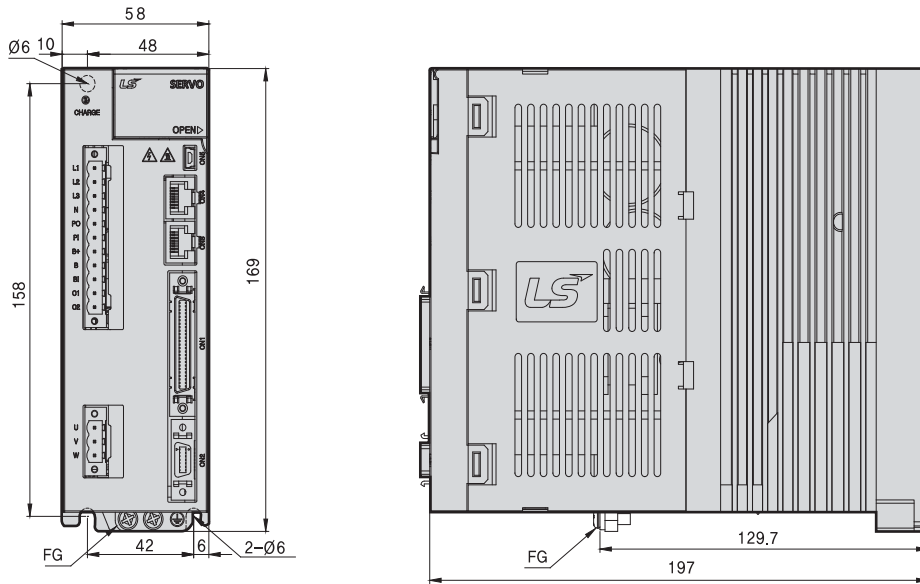

XDL-L7SA020 ~ XDL-L7SA035 [Weight : 2.5kg(Fan-Cooling included)]

*Unit [mm]

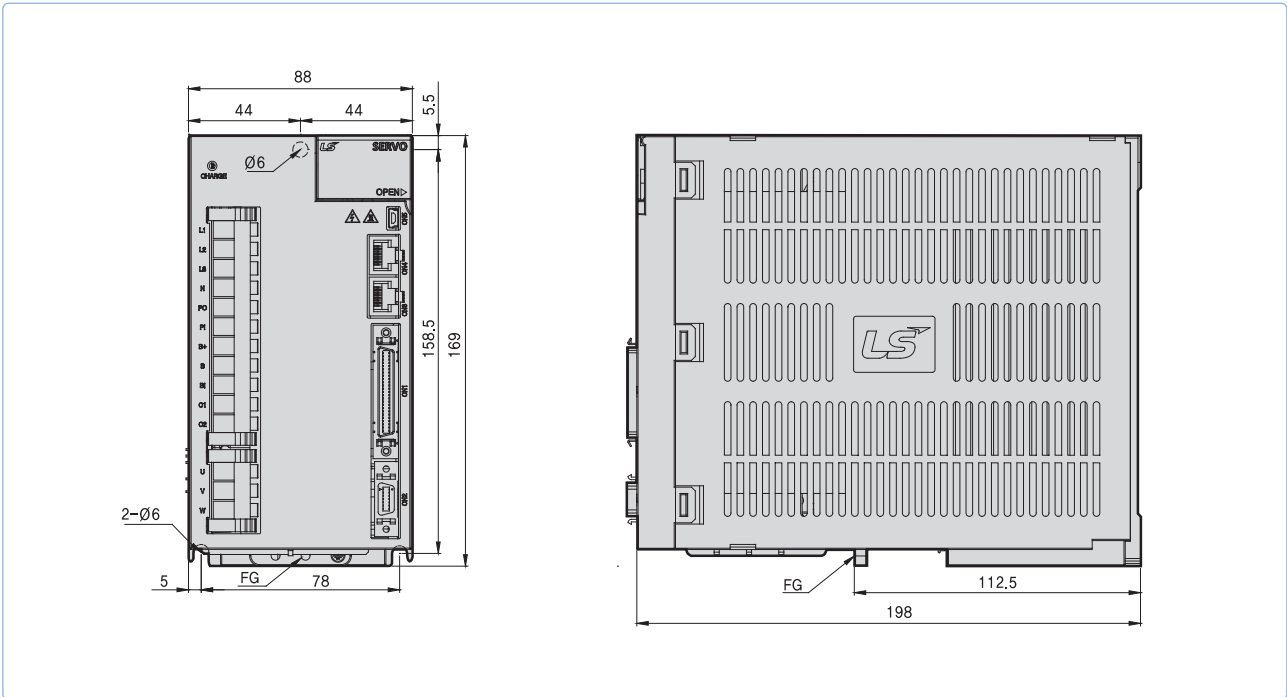

XDL-L7SA050 [Weight : 5.5kg(Fan-Cooling included)]

*Unit [mm]

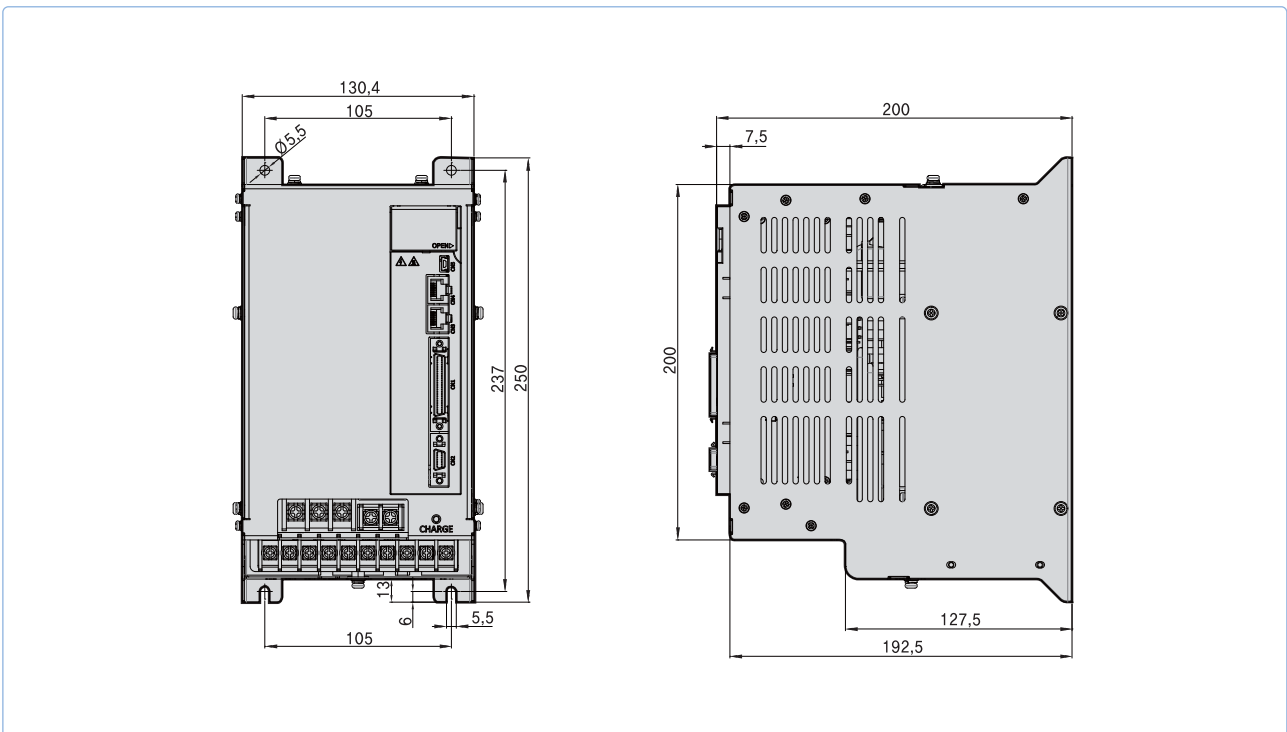

XDL-L7SB010 [Weight : 1.5kg(Fan-Cooling included)]

*Unit [mm]

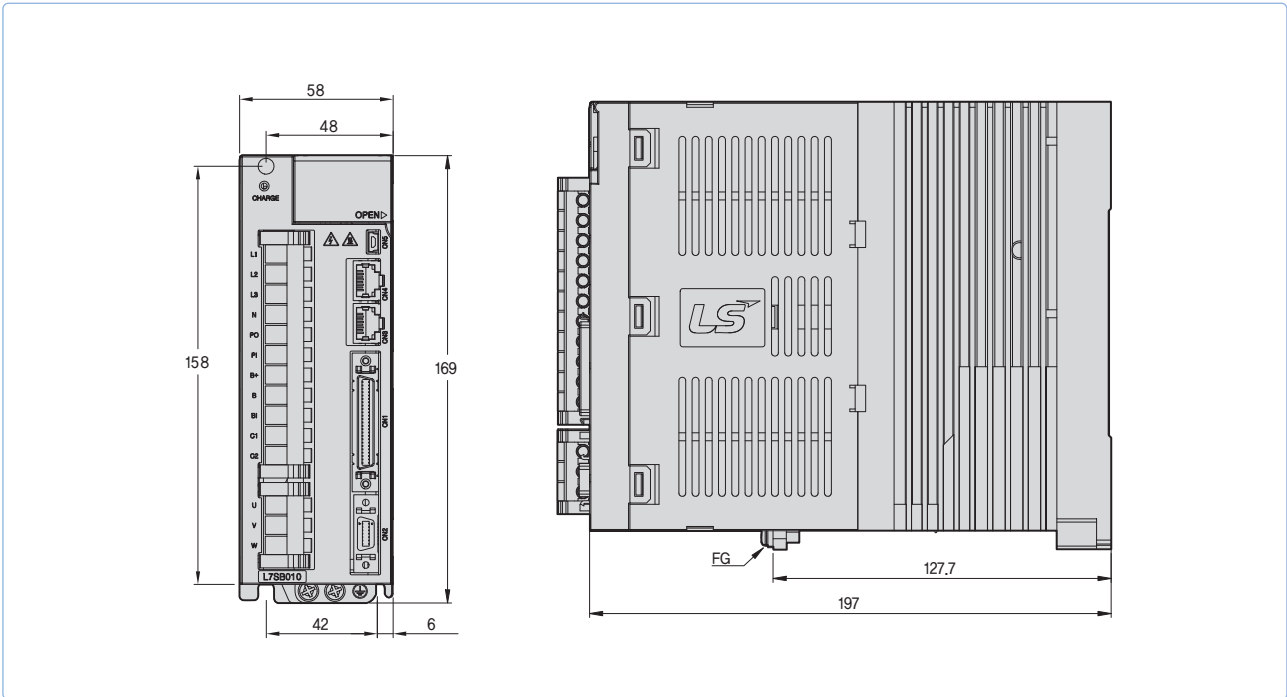

XDL-L7SB020 / **XDL-L7SB035** [Weight : 2.5kg(Fan-Cooling included)]

*Unit [mm]

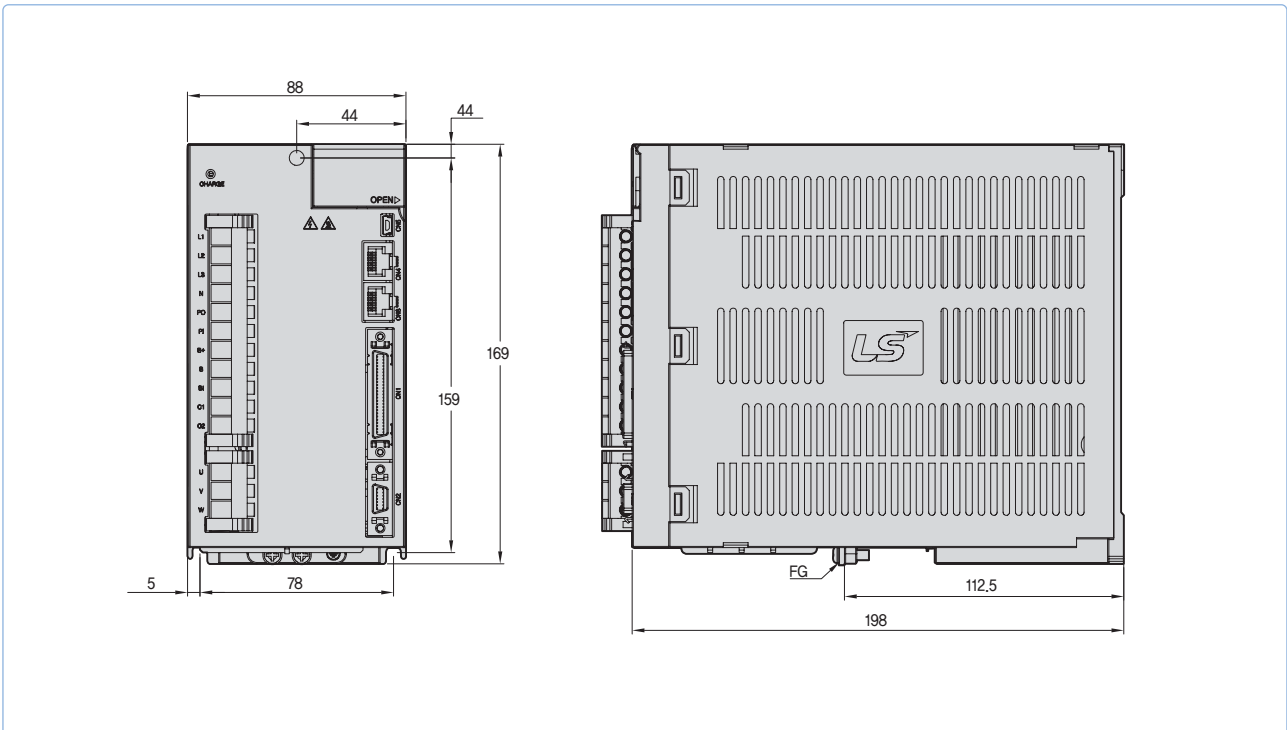

XDL-L7SB050 [Weight : 5.5kg(Fan-Cooling included)]

*Unit [mm]

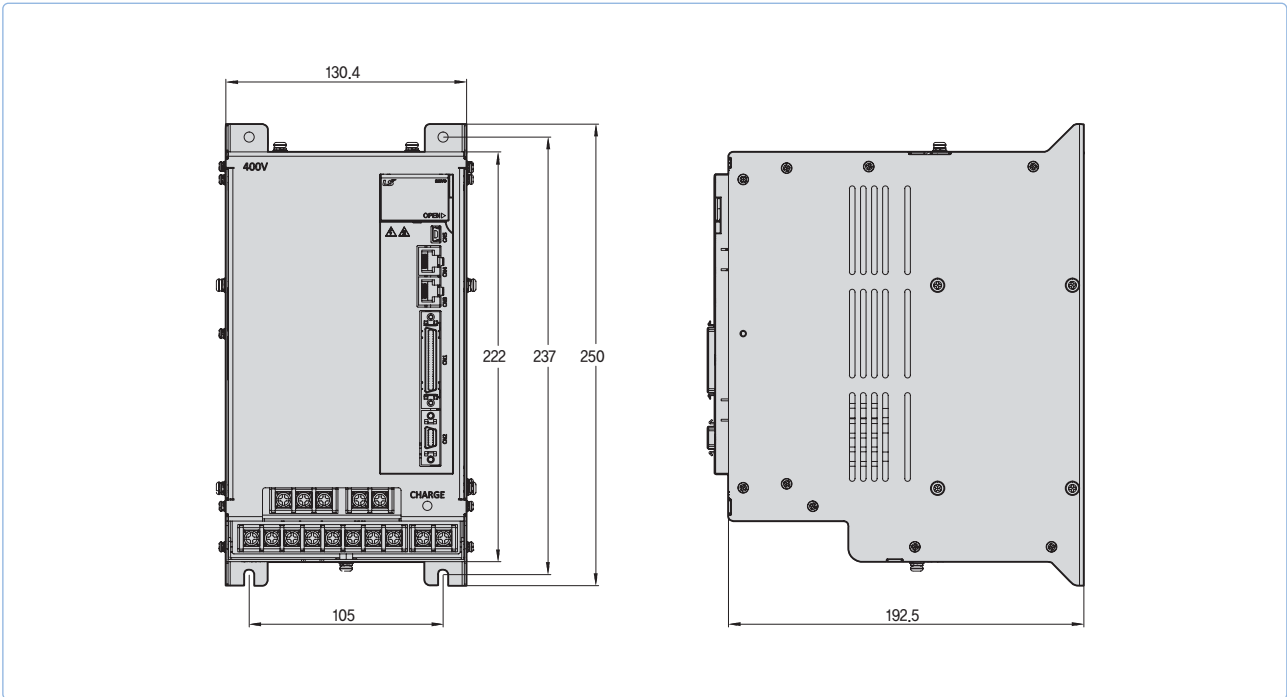

XDL-L7SA075 [Weight : 8.5kg(Fan-Cooling included)]

*Unit [mm]

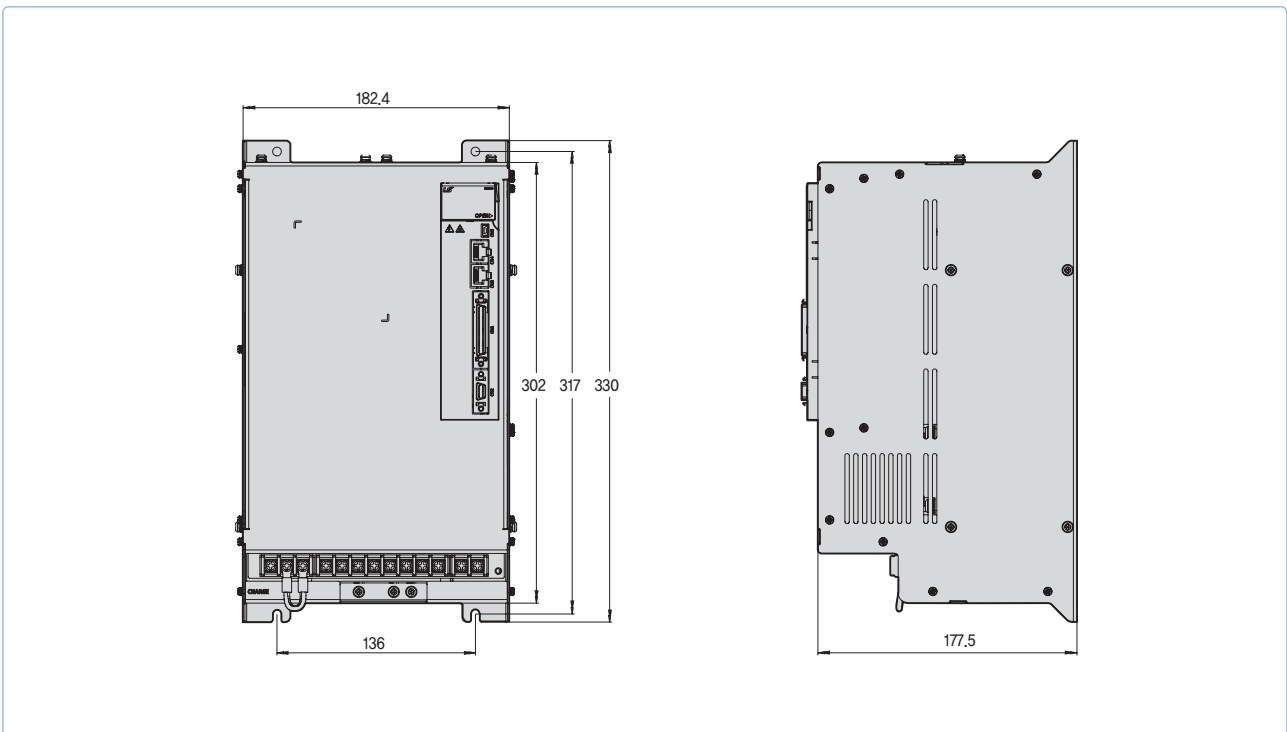

XDL-L7SB150 [Weight : 15.5kg(Fan-Cooling included)]

*Unit [mm]

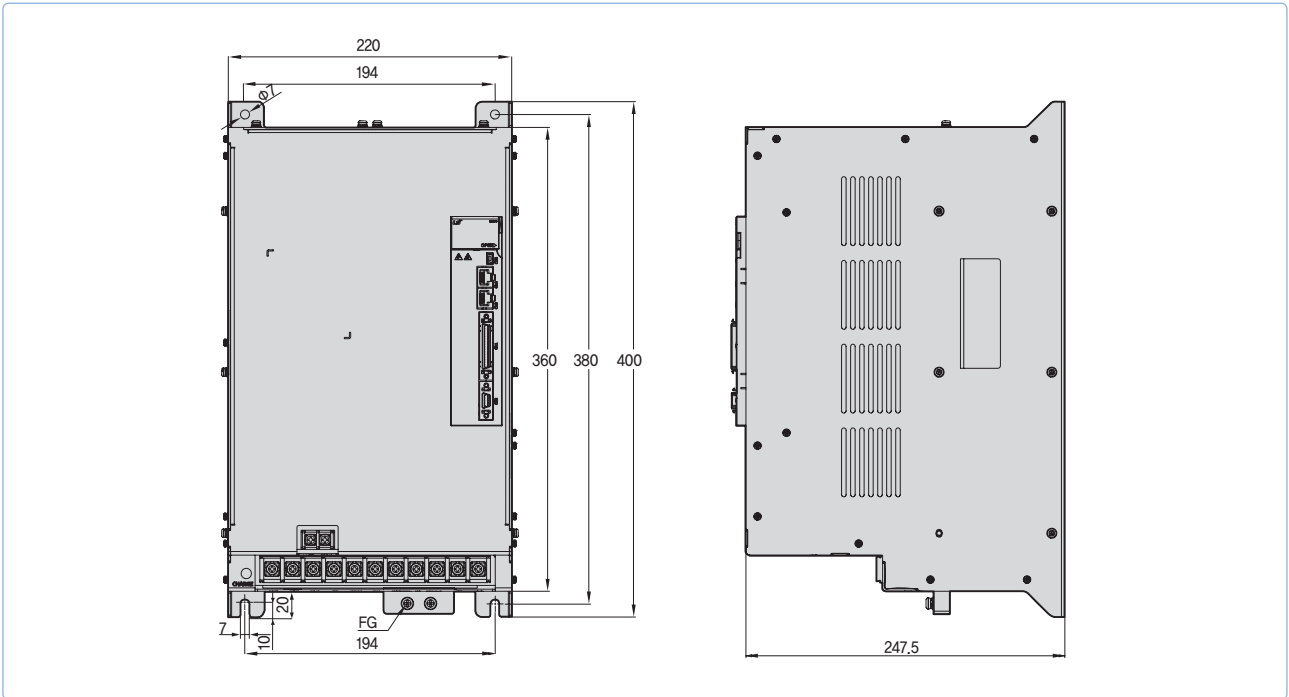

XDL-L7N Series



Servo Drive Designation

XDL	-	L7	N	A	004	B	AA
Model Name		Communication	Input Power Supply	Capacity	Encoder Type	Option	
XDL Series		Network Type	A : 200VAC	001 : 100W 002 : 200W 004 : 400W 008 : 750W 010 : 1.0kW 020 : 2.0kW 035 : 3.5kW 050 : 5.0kW	B : Serial (Communication Type)	Exclusive Option Code	

EtherCAT Communication Type **XDL-L7N**

Real-time control by EtherCAT

- High speed, Real-time capability and Synchronization mechanism
- 100BASE-TX(100Mbps) EtherNET based real-time communication

Support Various Operation Mode

- Cyclic(P/S/T) Mode and Profile (P/S/T)Mode, Homing Mode

High Response for Precision Control

- High Resolutions Serial type Encoder(19Bit, BiSS)
- Improved Speed Response(=1Khz) Frequency

- 1 Operation keys (Mode, Up, Down, Set)
- 2 Charge lamp
- 3 Main power connector (L1, L2, L3)
- 4 DC reactor connector(PO, PI)
 - Short circuit when not used
- 5 Regenerative Resistor Connector (B+, B, BI)
 - Short-Circuit B, BI terminals when standard type
 - Use B+, B terminals when using external resistor
- 6 Control Power Connector (C1, C2)
- 7 Front cover
- 8 Servo Motor Connecting Terminals (U, V, W)
- 9 Heat Sink
- 10 Display
- 11 Status LED
- 12 CN5:USB connector
- 13 CN4:EtherCAT Communication Port (IN)
- 14 CN3:EtherCAT Communication Port (OUT)
- 15 CN6 : STO Connector
- 16 CN1 : Control Signal Connector
- 17 CN2 : Encoder Signal Connector
- 18 Ground

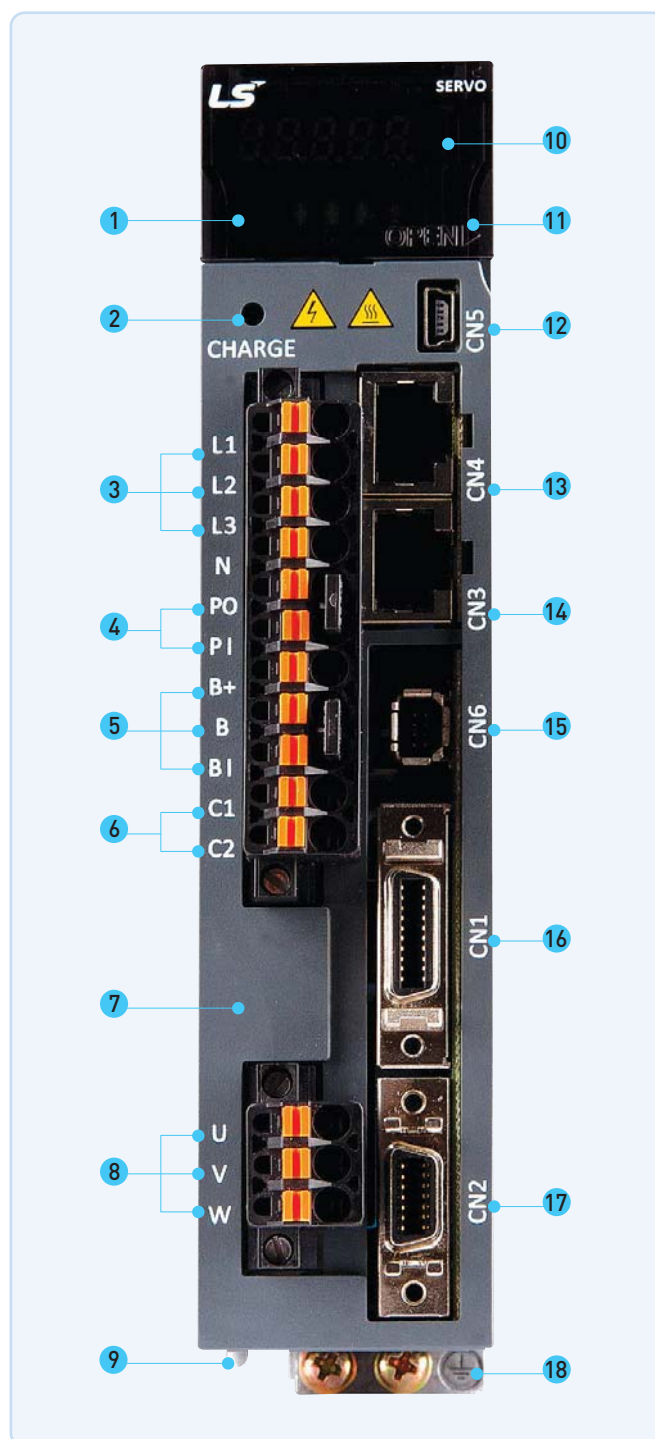

XDL-L7N Serial Type

Rated Speed (rpm)	Maximum Speed (rpm)	Flange Size	Applicable Motor	Applicable Drive	Standard Encoder Type	Encoder Cable		Power Cable		
					Serial Type	Serial	Abs	For power	Power + Brake	Brake
3,000	5,000	□40	FALR5A	L7NA001B	* 18Bit Serial/ M-Turn Abs	XLCS- E□□□ES	XLCS- E□□□ES1	XLCS- P□□□LS		XLCS- P□□□QS
		□40	FAL01A	L7NA001B						
		□40	FAL015A	L7NA002B						
		□60	FBL01A	L7NA001B						
		□60	FBL02A	L7NA002B						
		□60	FBL04A	L7NA004B						
		□80	FCL04A	L7NA004B						
		□80	FCL06A	L7NA008B						
		□80	FCL08A	L7NA008B						
		□80	FCL10A	L7NA010B						
		□60	FB01A	L7NA001B						
		□60	FB02A	L7NA002B						
		□60	FB04A	L7NA004B						
		□80	FC04A	L7NA004B						
		□80	FC06A	L7NA008B						
		□80	FC08A	L7NA008B						
		□80	FC10A	L7NA010B						
		□130	FE09A	L7NA010B						
		□130	FE15A	L7NA020B						
		□130	FE22A	L7NA020B						
□130	FE30A	L7NA035B								
□180	FF30A	L7NA035B								
□180	FF50A	L7NA050B								
2,000	3,000	□80	FCL03D	L7NA004B	* 19Bit Serial/ M-Turn Abs	XLCS- E□□□ES	XLCS- E□□□ES1	XLCS- P□□□LS		XLCS- P□□□QS
		□80	FCL05D	L7NA008B						
		□80	FCL06D	L7NA008B						
		□80	FCL07D	L7NA008B						
		□80	FC03D	L7NA004B						
		□80	FC05D	L7NA008B						
		□80	FC06D	L7NA008B						
		□80	FC07D	L7NA008B						
		□130	FE06D	L7NA008B						
		□130	FE11D	L7NA010B						
		□130	FE16D	L7NA020B						
		□130	FE22D	L7NA020B						
		□180	FF22D	L7NA020B						
		□180	FF35D	L7NA035B						
		□180	FF55D	L7NA050B						
		3,000	□220	FG22D				L7NA020B		
2,700	□220	FG35D	L7NA035B							
3,000	□220	FG55D	L7NA050B							
1,500	3,000	□130	FE05G	L7NA008B	XLCS- E□□□DS	XLCS- E□□□DS1	XLCS- P□□□HS	XLCS- P□□□NB		
		□130	FE09G	L7NA010B						
		□130	FE13G	L7NA020B						
		□130	FE17G	L7NA020B						
	□180	FF20G	L7NA020B							
	2,700	□180	FF30G	L7NA035B						
	3,000	□180	FF44G	L7NA050B						
	3,000	□220	FG20G	L7NA020B						
	2,700	□220	FG30G	L7NA035B						
	3,000	□220	FG44G	L7NA050B						
1,000	2,000	□130	FE03M	L7NA004B	XLCS- E□□□DS	XLCS- E□□□DS1	XLCS- P□□□HS	XLCS- P□□□NB		
		□130	FE06M	L7NA008B						
		□130	FE09M	L7NA010B						
		□130	FE12M	L7NA020B						
		□180	FF12M	L7NA020B						
		□180	FF20M	L7NA020B						
	1,700	□180	FF30M	L7NA035B						
	2,000	□180	FF44M	L7NA050B						
		□220	FG12M	L7NA020B						
		□220	FG20M	L7NA020B						
1,700		□220	FG30M	L7NA035B						
2,000	□220	FG44M	L7NA050B							

XDL-L7NA Drive

Item		Type Name	XDL-L7NA001B	XDL-L7NA002B	XDL-L7NA004B	XDL-L7NA008B	XDL-L7NA010B	XDL-L7NA020B	XDL-L7NA035B	XDL-L7NA050B
Input Power	Main Power Supply	3 Phase AC200 ~ 230[V](-15 ~ +10[%]), 50 ~ 60[Hz]								
	Control Power Supply	Single Phase AC200 ~ 230[V](-15 ~ +10[%]), 50 ~ 60[Hz]								
Rated Current[A]		1.4	1.7	3.0	5.2	6.75	13.5	16.7	32	
Peak Current[A]		4.2	5.1	9.0	15.6	20.25	40.5	50.1	96	
Encoder Type		Quad. Type Incremental Line Driver Max 6000 [P/R] Serial Type 19Bit								
Control Performance	Speed Control Range	Maximum 1: 5000								
	Frequency Response	Maximum 1 kHz or more (when the 19-bit serial encoder is applied)								
	Speed Variation Ratio	±0.01[%] or lower(When the load changes between 0 and 100%), ±0.1[%] or less(Temperature of 25°C[±10])								
	Torque Control Repetition Accuracy	Within ±1%								
Supported Drive Modes (CiA402)		Profile Position Mode Profile Velocity Mode Profile Torque Mode Interpolated Position Mode Cyclic Synchronous Position Mode Cyclic Synchronous Velocity Mode Cyclic Synchronous Torque Mode Homing Mode								
Digital Input/Output	Digital Input	Total 6 input channels (allocable) PCON, GAIN2, ALMRST, HOME, P-OT, N-OT Above 6 functions can be used selectively for assignment. Signal can be set as positive logic or negative logic.								
	Touch Probe Input	There are 2 input channels. Provides rising and falling edge detection functions for each channel.								
	Digital Output	Total 4 channels (allocable) ALARM, READY, ZSPD, BRAKE, INPOS, INSPD, WARN Above 7 outputs can be used selectively for assignment. Signal can be set as positive logic or negative logic.								
Additional Communication	USB	Program download is available with USB Communication.								
Built-in Functions	Dynamic Braking	Built-in type(operates when Servo alarm or Servo off)								
	Regenerative Braking	Built-in type, and also external connection is available								
	Display	7 segments(5DIGIT)								
	Setting Function	Loder{SET}, (MODE)								
	Additional Function	Auto gain tuning function								
Operation Environment	Protective Function	Overcurrent, overload, overvoltage, insufficient voltage, main power input problem, control power input problem, overspeed, motor cable, overheat(power module overheat, abnormal drive operation ^o s temp), encoder problem, over-regenerative, sensor problem, communication problem								
	Temperature	0 ~ 50[°C]								
	Humidity	Below 90[%]RH(avoid dew-condensation)								
Environment		Indoor, Avoid corrosive, inflammable gas or liquid, and electrically conductive dust.								

XDL-L7NA001B ~ XDL-L7NA004B [Weight : 1.2kg]

*Unit [mm]

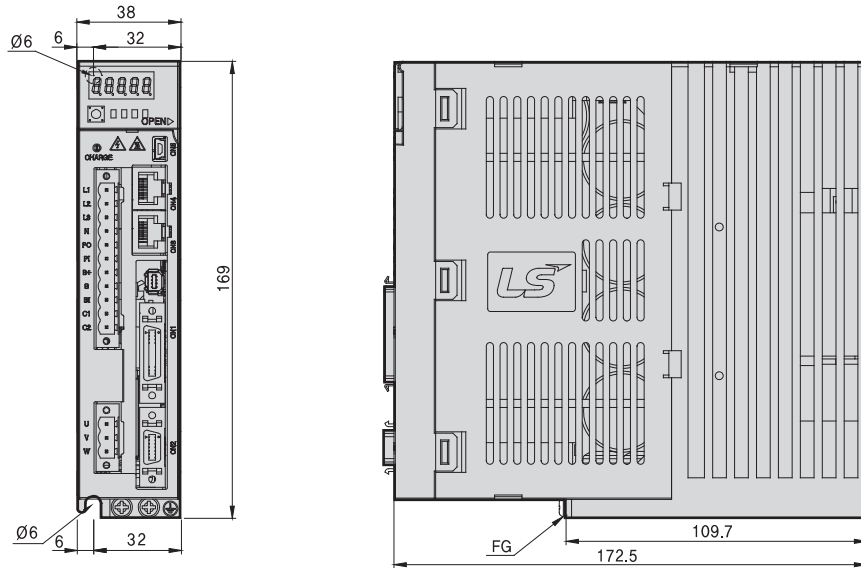

XDL-L7NA008B / XDL-L7NA010B [Weight : 1.5kg (Fan-Cooling included)]

*Unit [mm]

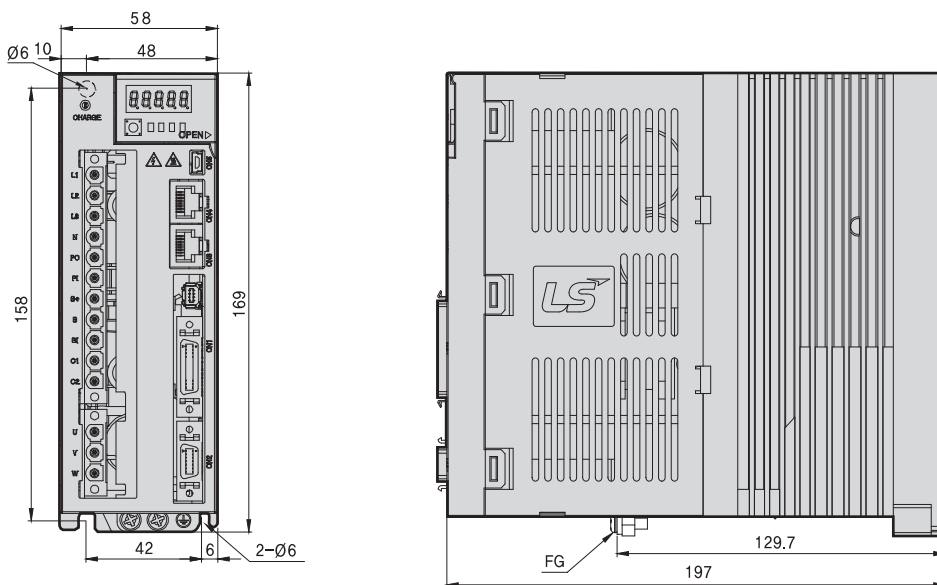

XDL-L7NA020B / XDL-L7NA035B[Weight : 2.5kg(Fan-Cooling included)]

*Unit [mm]

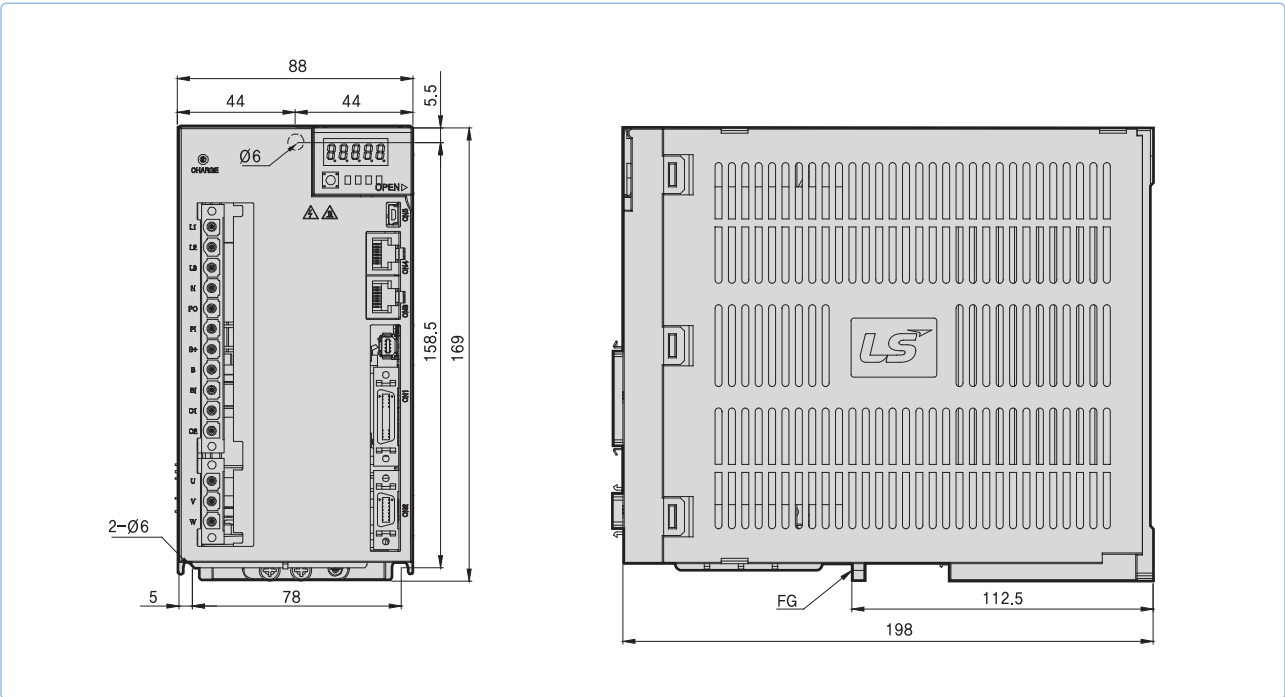

XDL-L7NA050B[Weight : 5.5kg(Fan-Cooling included)]

*Unit [mm]

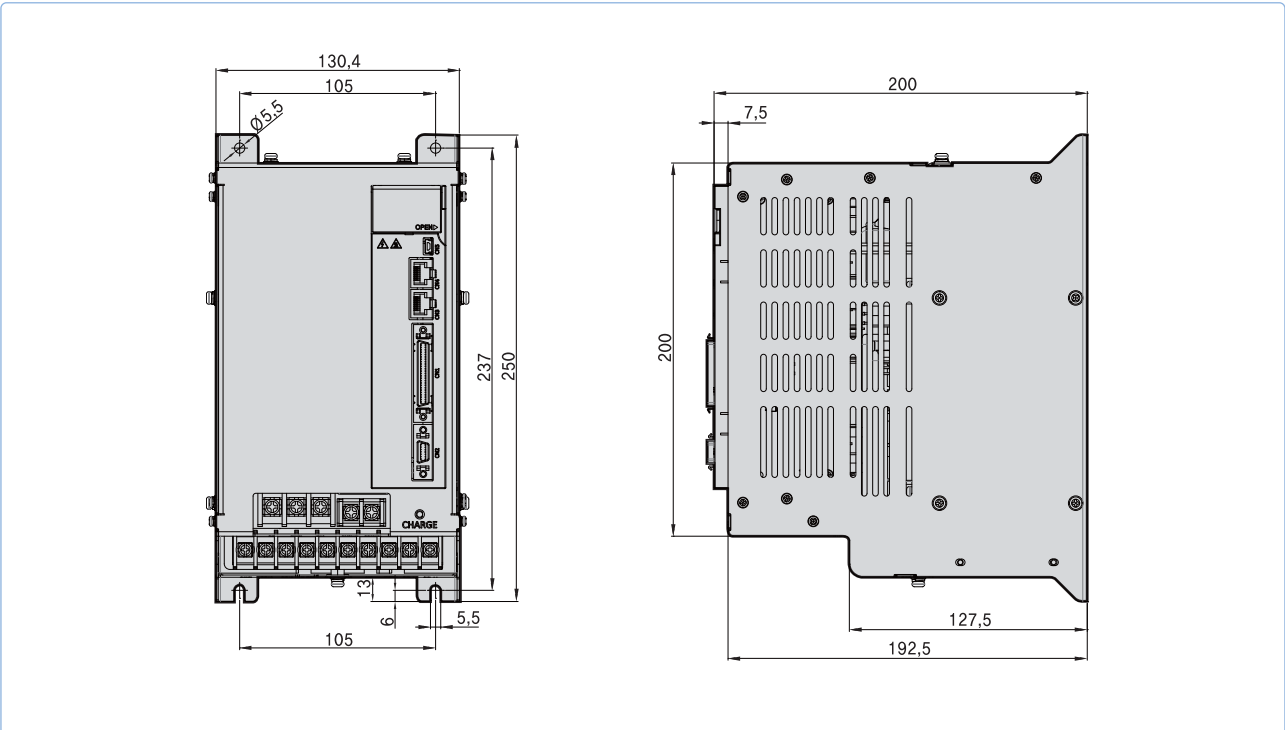

XDL-L7NH Series



Servo Drive Designation

XDL - L7	NH	A	004	B	AA
Model Name	Communication	Input Power Supply	Capacity	Encoder Type	Option
XDL Series	Network / All-in-One Type	A:200VAC B:400VAC	001:100W 002:200W 004:400W 008:750W 010:1.0kW 020:2.0kW 035:3.5kW 050:5.0kW 075:7.5kW 110:11kW 150:15kW	U:Universal	Exclusive Option Code

* Range

- 200V : 0.1kW~3.5kW
- 400V : 1.0kW~15kW

All-in-One EtherCAT Communication Type **XDL-L7NH**

Real-time control through EtherCAT

- High speed, Real-time capability and Synchronization mechanism
- Improved EtherCAT communication speed (min. 250us, DC support)
- Supporting CoE, EoE and FoE
- Improved Speed Response(=1.6Khz) Frequency

Support various motor and Encoder drive

- Supporting Rotary, DD and Motor drive (supporting 3rd party motor)
- Quadrature, BiSS-C, Tamagawa serial abs, EnDat 2.2, Resolver

Improved Control Performance

- Improved Control bandwidth
- Providing 4-step Notch-Filter
- Vibration control by Real-time FET
- Real-time gain tuning function

- 1 Display
- 2 State LED
- 3 Charge Lamp
- 4 Main Power Connector (L1, L2, L3)
- 5 DC Reactor Connector (PO, PI)
- 6 Regenerative Resistance Connector (B+, B, BI)
 - Short-Circuit B, BI terminals when standard type
 - Use B+, B terminals when using external resistor
- 7 Control Power Connector (C1, C2)
- 8 Servo Motor Connecting Terminal (U,V,W)
- 9 Connector for Analog Monitor
- 10 Node Address Setting Switch
- 11 USB Connector
- 12 EtherCAT Communication Port (IN)
- 13 EtherCAT Communication Port (OUT)
- 14 Safety Connector (STO)
- 15 Input / Output signal /Connector
- 16 Encoder Connector (ENCODER)
- 17 Ground Terminal

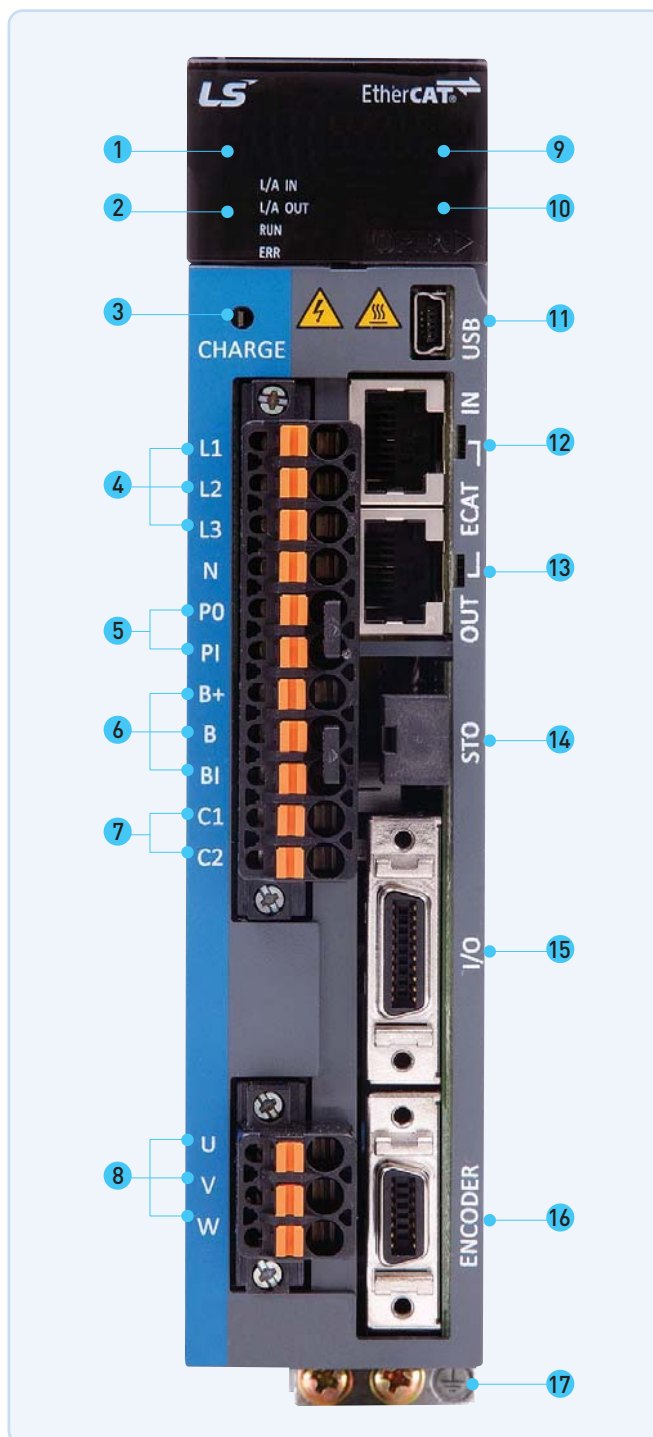

XDL-L7NHA Incremental Type

Rated Speed (rpm)	Maximum Speed (rpm)	Flange Size	Applicable Motor	Applicable Drive	Standard Encoder Type	Encoder Cable	Power Cable									
					Quadrature Type	INC	For power	Power + Brake	Brake							
3,000	5,000	□40	SAR3A	L7NHA001U	* 2,048P/R	XLCS-E□□□AS	XLCS-P□□□GS	XLCS-P□□□KB								
		□40	SAR5A	L7NHA001U												
		□40	SA01A	L7NHA001U												
		□40	SA015A	L7NHA002U												
		□60	SB01A	L7NHA002U												
		□60	SB02A	L7NHA002U												
		□60	SB04A	L7NHA004U												
		□80	SC04A	L7NHA004U												
		□80	SC06A	L7NHA008U												
		□80	SC08A	L7NHA008U												
		□80	SC10A	L7NHA010U												
		□130	SE09A	L7NHA008U												
		□130	SE15A	L7NHA020U												
		□130	SE22A	L7NHA020U												
2,000	3,000	□80	SC03D	L7NHA004U	* 3,000P/R	XLCS-E□□□AS	XLCS-P□□□GS	XLCS-P□□□NB	XLCS-P□□□SB							
		□80	SC05D	L7NHA008U												
		□80	SC06D	L7NHA008U												
		□80	SC07D	L7NHA008U												
		□130	SE06D	L7NHA008U												
		□130	SE11D	L7NHA010U												
		□130	SE16D	L7NHA020U												
		□130	SE22D	L7NHA020U												
		□180	SF22D	L7NHA020U												
		□180	LF35D	L7NHA035U												
		□220	SG22D	L7NHA020U												
		□220	LG35D	L7NHA035U												
		1,500	3,000	□130						SE05G	L7NHA008U	* 3,000P/R	XLCS-E□□□BS	XLCS-P□□□HS	XLCS-P□□□NB	XLCS-P□□□SB
				□130						SE09G	L7NHA010U					
□130	SE13G			L7NHA020U												
□130	SE17G			L7NHA020U												
2,700	3,000		□180	SF20G	L7NHA035U	* 3,000P/R	XLCS-P□□□IS	XLCS-P□□□PB	XLCS-P□□□SB							
			□220	SG20G	L7NHA020U											
			□220	LG30G	L7NHA035U											
1,000	2,000	□130	SE03M	L7NHA004U	* 3,000P/R	XLCS-E□□□BS	XLCS-P□□□HS	XLCS-P□□□NB	XLCS-P□□□SB							
		□130	SE06M	L7NHA008U												
		□130	SE09M	L7NHA010U												
		□130	SE12M	L7NHA020U												
		□180	SF12M	L7NHA020U												
		□180	SF20M	L7NHA035U												
	1,700	2,000	□180	LF30M						L7NHA035U	* 3,000P/R	XLCS-P□□□IS	XLCS-P□□□PB	XLCS-P□□□SB		
			□220	SG12M						L7NHA020U						
			□220	SG20M						L7NHA035U						
			□220	LG30M						L7NHA035U						
3,000	3,500	□60	HB01A	L7NHA002U	* 1,048P/R	XLCS-E□□□AS	XLCS-P□□□GS	XLCS-P□□□SB								
		□60	HB02A	L7NHA002U												
		□60	HB04A	L7NHA004U												
		□130	HE09A	L7NHA008U												
		□130	HE15A	L7NHA020U												
3,000	3,500	□60	HB01A	L7NHA002U	* 1,048P/R	XLCS-E□□□BS	XLCS-P□□□HS	XLCS-P□□□SB								
		□60	HB02A	L7NHA002U												
		□60	HB04A	L7NHA004U												
		□130	HE09A	L7NHA008U												
		□130	HE15A	L7NHA020U												

XDL-L7NHA Serial Type

Rated Speed (rpm)	Maximum Speed (rpm)	Flange Size	Applicable Motor	Applicable Drive	Standard Encoder Type	Encoder Cable		Power Cable					
					Serial Type	Serial	Abs	For power	Power + Brake	Brake			
3,000	5,000	□40	FALR5A	L7NHA001U	* 18Bit Serial / M-Turn Abs	XLCS-E□□□ES	XLCS-E□□□ES1	XLCS-P□□□LS	XLCS-P□□□QS				
		□40	FAL01A	L7NHA001U									
		□40	FAL015A	L7NHA002U									
		□60	FBL01A	L7NHA001U									
		□60	FBL02A	L7NHA002U									
		□60	FBL04A	L7NHA004U									
		□80	FCL04A	L7NHA004U									
		□80	FCL06A	L7NHA008U									
		□80	FCL08A	L7NHA008U									
		□80	FCL10A	L7NHA010U									
		□60	FB01A	L7NHA001U				XLCS-P□□□FS					
		□60	FB02A	L7NHA002U									
		□60	FB04A	L7NHA004U									
		□80	FC04A	L7NHA004U									
		□80	FC06A	L7NHA008U									
		□80	FC08A	L7NHA008U									
		□80	FC10A	L7NHA010U									
		□130	FE09A	L7NHA010U						XLCS-E□□□DS	XLCS-E□□□DS1	XLCS-P□□□HS	XLCS-P□□□NB
		□130	FE15A	L7NHA020U									
		□130	FE22A	L7NHA020U									
□130	FE30A	L7NHA035U											
□180	FF30A	L7NHA035U											
2,000	3,000	□80	FCL03D	L7NHA004U	* 19Bit Serial / M-Turn Abs	XLCS-E□□□ES	XLCS-E□□□ES1	XLCS-P□□□LS	XLCS-P□□□QS				
		□80	FCL05D	L7NHA008U									
		□80	FCL06D	L7NHA008U									
		□80	FCL07D	L7NHA008U									
		□80	FC03D	L7NHA004U									
		□80	FC05D	L7NHA008U									
		□80	FC06D	L7NHA008U									
		□80	FC07D	L7NHA008U									
		□130	FE06D	L7NHA008U				XLCS-P□□□FS					
		□130	FE11D	L7NHA010U									
		□130	FE16D	L7NHA020U									
		□130	FE22D	L7NHA020U									
		□180	FF22D	L7NHA020U									
		□180	FF35D	L7NHA035U									
		□220	FG22D	L7NHA020U									
		□220	FG35D	L7NHA035U									
1,500	3,000	□130	FE05G	L7NHA008U	XLCS-E□□□DS	XLCS-E□□□DS1	XLCS-P□□□HS	XLCS-P□□□NB					
		□130	FE09G	L7NHA010U									
		□130	FE13G	L7NHA020U									
		□130	FE17G	L7NHA020U									
	□180	FF20G	L7NHA020U	XLCS-P□□□IS			XLCS-P□□□PB						
	□180	FF30G	L7NHA035U										
	□220	FG20G	L7NHA020U										
□220	FG30G	L7NHA035U	XLCS-P□□□IS	XLCS-P□□□PB	XLCS-P□□□SB								
□220	FG30M	L7NHA035U											
1,000	2,000	□130	FE03M	L7NHA004U	XLCS-E□□□DS	XLCS-E□□□DS1	XLCS-P□□□HS	XLCS-P□□□NB					
		□130	FE06M	L7NHA008U									
		□130	FE09M	L7NHA010U									
		□130	FE12M	L7NHA020U									
		□180	FF12M	L7NHA020U									
		□180	FF20M	L7NHA020U									
	□180	FF30M	L7NHA035U	XLCS-P□□□IS			XLCS-P□□□PB	XLCS-P□□□SB					
	□220	FG12M	L7NHA020U										
	□220	FG20M	L7NHA020U										
	□220	FG30M	L7NHA035U										



XDL-L7NHB Incremental Type

Rated Speed (rpm)	Maximum Speed (rpm)	Flange Size	Applicable Motor	Applicable Drive	Standard Encoder Type	Encoder Cable	Power Cable		
					Quadrature Type	INC	For power	Power + Brake	Brake
3,000	5,000	□ 130	SEP09A	L7NHB010U	* 3,000P/R	XLCS-E□□□BS	XLCS-P□□□HS	XLCS-P□□□NB	
		□ 130	SEP15A	L7NHB010U					
		□ 130	SEP22A	L7NHB020U					
		□ 130	SEP30A	L7NHB035U					
		□ 180	SFP30A	L7NHB035U					
		□ 180	SFP50A	L7NHB050U					
2,000	3,000	□ 130	SEP06D	L7NHB010U					
		□ 130	SEP11D	L7NHB010U					
		□ 130	SEP16D	L7NHB020U					
		□ 130	SEP22D	L7NHB020U					
		□ 180	SFP22D	L7NHB020U					
		□ 180	SFP35D	L7NHB035U					
		□ 180	SFP55D	L7NHB050U					
		□ 180	SFP75D	L7NHB075U					
		□ 220	SGP22D	L7NHB020U					
		□ 220	SGP35D	L7NHB035U					
	□ 220	SGP55D	L7NHB050U						
	2,500		□ 220	SGP75D			L7NHB075U		
			□ 220	SGP110D			L7NHB150U		
			□ 220	SGP22D			L7NHB020U		
□ 220			SGP35D	L7NHB035U					
1,500	3,000	□ 130	SEP05G	L7NHB010U					
		□ 130	SEP09G	L7NHB010U					
		□ 130	SEP13G	L7NHB020U					
		□ 130	SEP17G	L7NHB020U					
		□ 180	SFP20G	L7NHB020U					
		□ 180	SFP30G	L7NHB050U					
		□ 180	SFP44G	L7NHB050U					
		□ 180	SFP60G	L7NHB075U					
	2,500		□ 180	SFP75G	L7NHB075U				
			□ 220	SGP20G	L7NHB020U				
			□ 220	SGP30G	L7NHB050U				
			□ 220	SGP44G	L7NHB050U				
			□ 220	SGP60G	L7NHB075U				
			□ 220	SGP85G	L7NHB150U				
2,000		□ 220	SGP110G	L7NHB150U					
		□ 220	SGP150G	L7NHB150U					
		□ 220	SGP20G	L7NHB020U					
		□ 220	SGP30G	L7NHB050U					
1,000	2,000	□ 130	SEP03M	L7NHB010U					
		□ 130	SEP06M	L7NHB010U					
		□ 130	SEP09M	L7NHB010U					
		□ 130	SEP12M	L7NHB020U					
		□ 180	SFP12M	L7NHB020U					
		□ 180	SFP20M	L7NHB020U					
	1,700		□ 180	SFP30M	L7NHB035U				
			□ 180	SFP44M	L7NHB050U				
	2,000		□ 220	SGP12M	L7NHB020U				
			□ 220	SGP20M	L7NHB020U				
			□ 220	SGP30M	L7NHB050U				
			□ 220	SGP44M	L7NHB050U				
			□ 220	SGP60M	L7NHB075U				
			□ 220	SGP75M	L7NHB075U				

XDL-L7NHB Serial Type

Rated Speed (rpm)	Maximum Speed (rpm)	Flange Size	Applicable Motor	Applicable Drive	Standard Encoder Type	Encoder Cable		Power Cable		
					Serial Type	Serial	Abs	For power	Power + Brake	Brake
3,000	5,000	□130	FEP09A	L7NHB010U	* 19Bit Serial/ M-Turn Abs	XLCS- E□□□DS	XLCS- E□□□DS1	XLCS- P□□□HS	XLCS- P□□□NB	
		□130	FEP15A	L7NHB020U						
		□130	FEP22A	L7NHB035U						
		□130	FEP30A	L7NHB035U						
		□180	FFP30A	L7NHB035U						
		□180	FFP50A	L7NHB050U						
2,000	3,000	□130	FEP06D	L7NHB010U						
		□130	FEP11D	L7NHB010U						
		□130	FEP16D	L7NHB020U						
		□130	FEP22D	L7NHB020U						
		□180	FFP22D	L7NHB020U						
		□180	FFP35D	L7NHB035U						
	2,500	3,000	□180	FFP55D				L7NHB050U		
			□180	FFP75D				L7NHB075U		
			□220	FGP22D				L7NHB020U		
			□220	FGP35D				L7NHB035U		
			□220	FGP55D				L7NHB050U		
			□220	FGP75D				L7NHB075U		
1,500	3,000	□130	FEP05G	L7NHB010U						
		□130	FEP09G	L7NHB010U						
		□130	FEP13G	L7NHB020U						
		□130	FEP17G	L7NHB020U						
		□180	FFP20G	L7NHB020U						
		□180	FFP30G	L7NHB050U						
	2,700	3,000	□180	FFP44G				L7NHB050U		
			□180	FFP60G				L7NHB075U		
			□180	FFP75G				L7NHB075U		
			□220	FGP20G				L7NHB020U		
			□220	FGP30G				L7NHB035U		
			□220	FGP44G				L7NHB050U		
2,500	2,000	□220	FGP60G	L7NHB075U						
		□220	FGP85G	L7NHB150U						
		□220	FGP110G	L7NHB150U						
		□220	FGP150G	L7NHB150U						
		2,000	2,000	□130				FEP03M	L7NHB010U	
				□130				FEP06M	L7NHB010U	
□130	FEP09M			L7NHB010U						
□130	FEP12M			L7NHB020U						
□180	FFP12M			L7NHB020U						
□180	FFP20M			L7NHB020U						
1,000	1,700	□180	FFP30M	L7NHB035U						
		□180	FFP44M	L7NHB050U						
		□220	FGP12M	L7NHB020U						
		□220	FGP20M	L7NHB020U						
		□220	FGP30M	L7NHB050U						
		□220	FGP44M	L7NHB050U						
2,000	2,000	□220	FGP60M	L7NHB075U						
		□220	FGP12M	L7NHB020U						
		□220	FGP20M	L7NHB020U						
		□220	FGP30M	L7NHB050U						
		□220	FGP44M	L7NHB050U						
		□220	FGP60M	L7NHB075U						

Servo Drive

XDL-L7NHA Drive

Item		Type Name	XDL-L7NHA001U	XDL-L7NHA002U	XDL-L7NHA004U	XDL-L7NHA008U	XDL-L7NHA010U	XDL-L7NHA020U	XDL-L7NHA035U
Input Power	Main Power Supply	3 Phase AC200 ~ 230[V](-15 ~ +10[%]), 50 ~ 60[Hz]							
	Control Power Supply	Single Phase AC200 ~ 230[V](-15 ~ +10[%]), 50 ~ 60[Hz]							
Rated Current[A]		1.4	1.7	3.0	5.2	6.75	13.5	16.7	
Peak Current[A]		4.2	5.1	9.0	15.6	20.25	40.5	50.1	
Encoder Type		Quadrature(Incremental) BiSS-B, BiSS-C(Absolute, Incremental) Tamagawa Serial(Absolute, Incremental) EnDat 2.2							
Control Performance	Speed Control Range	Maximum 1: 5000							
	Frequency Response	Maximum 1[kHz] or above(When the 19-bit Serial Encoder is applied)							
	Speed Variation Ratio	±0.01[%] or lower(When the load changes between 0 and 100%) ±0.1[%] or less(Temperature of 25°C[±10])							
	Torque Control Repetition Accuracy	Within ±1%							
EtherCAT Communication Specifications	Communication Standard	FoE (Firmware download) EoE (Parameter setting by UDP, Tuning, Secondary function, Parameter copy) CoE (IEC 61158 Type12, IEC 61800-7 CIA 402 Drive profile)							
	Physical Layer	100BASE-TX(IEEE802.3)							
	Connector	RJ45 x 2							
	Communication distance	Within connection between nodes 100[m]							
	DC(Distributed Clock)	By DC mode synchronism. minimum DC cycle: 250[us]							
	LED Display	LinkAct IN, LinkAct OUT, RUN, ERR							
	Cia402 Drive Profile	Profile Position Mode Profile Velocity Mode Profile Torque Mode Cyclic Synchronous Position Mode Cyclic Synchronous Velocity Mode Cyclic Synchronous Torque Mode Homing Mode							
Digital Input/Output	Digital Input	Input Voltage range : DC 12[V] ~ DC 24[V] Total 8 input channels (allocable) Above 12 functions can be used selectively for assignment. (*POT, *NOT, *HOME, *STOP, *PCON, *GAIN2, *P_CL, *N_CL, PROBE1, PROBE2, EMG, A_RST) *Basic allocation signal							
	Digital Output	Service rating: DC 24[V] ± 10%, 120[mA] Total 4 input channels (allocable) Above 11 functions can be used selectively for assignment. (*BRAKE±, *ALARM±, *READY±, *ZSPD±, INPOS±, TLMT±, VLMT±, INSPD±, WARN±, TGON±, INPOS±) *Basic allocation signal							
Analog Monitor		There are 2 input channels. Above 15 functions can be used selectively for assignment.							
Safety Function		2 Input Channels (STO1, STO2), 1 Output Channels (EDM±)							
USB Communication	Function	Firmware download, Parameter setting, Tuning, Secondary function, Parameter copy							
	Communication Standard	USB 2.0 Full Speed (applies standard)							
	Connect	PC or USB storing medium							
Internal Function	Dynamic Braking	Standard built-in brake (activated when the servo alarm goes off or when the servo is off).							
	Regenerative Braking	Both the default built-in brake and an externally installed brake are possible.							
	Display Function	7 segments(5DIGIT)							
	Self-setting Function	The [MODE] key changes the content displayed in 7 segments							
	Additional Function	Auto gain tuning function							
Protection Function		Overcurrent, overload, overvoltage, insufficient voltage, main power input problem, control power input problem, overspeed, motor cable, overheat(power module overheat, abnormal drive operation's temp), encoder problem, over-regenerative, sensor problem, communication problem							
Environment	Temperature	0 ~ +50[°C] / -20~ +70[°C]							
	Humidity	Below 90[%]RH(avoid dew-condensation)							
	Environment	Indoor, Avoid corrosive, inflammable gas or liquid, and electrically conductive dust.							

XDL-L7NHB Drive

Item		Type Name	XDL-L7NHB010U	XDL-L7NHB020U	XDL-L7NHB035U	XDL-L7NHB050U	XDL-L7NHB075U	XDL-L7NHB150U
Input Power	Main Power Supply	3 Phase AC380 ~480[V](-15 ~ +10[%]), 50 ~ 60[Hz]						
	Control Power Supply	Single Phase AC380 ~ 480[V](-15 ~ +10[%]), 50 ~ 60[Hz]						
Rated Current[A]			3.7	8	10.1	17.5	22.8	39
Peak Current[A]			11.1	24	30.3	47.25	57	97.5
Encoder Type			Quadrature(Incremental) BiSS-B, BiSS-C(Absolute, Incremental) Tamagawa Serial(Absolute, Incremental) EnDat 2.2					
Control Performance	Speed Control Range		Maximum 1: 5000					
	Frequency Response		Maximum 1[kHz] or above(When the 19-bit Serial Encoder is applied)					
	Speed Variation Ratio		$\pm 0.01[\%]$ or lower(When the load changes between 0 and 100%) $\pm 0.1[\%]$ or less(Temperature of 25°C[± 10])					
	Torque Control Repetition Accuracy		Within $\pm 1\%$					
EtherCAT Communication Specifications	Communication Standard		FoE (Firmware download) EoE (Parameter setting by UDP, Tuning, Secondary function, Parameter copy) CoE (IEC 61158 Type12, IEC 61800-7 CIA 402 Drive profile)					
	Physical Layer		100BASE-TX(IEEE802.3)					
	Connector		RJ45 x 2					
	Communication distance		Within connection between nodes 100[m]					
	DC(Distributed Clock)		By DC mode synchronism. minimum DC cycle: 250[us]					
	LED Display		LinkAct IN, LinkAct OUT, RUN, ERR					
	Cia402 Drive Profile		Profile Position Mode Profile Velocity Mode Profile Torque Mode Cyclic Synchronous Position Mode Cyclic Synchronous Velocity Mode Cyclic Synchronous Torque Mode Homing Mode					
Digital Input/Output	Digital Input		Input Voltage range : DC 12[V] ~ DC 24[V] Total 8 input channels (allocable) Above 12 functions can be used selectively for assignment. (*POT, *NOT, *HOME, *STOP, *PCON, *GAIN2, *P_CL, *N_CL, PROBE1, PROBE2, EMG, A_RST) *Basic allocation signal					
	Digital Output		Service rating: DC 24[V] $\pm 10\%$, 120[mA] Total 4 input channels (allocable) Above 11 functions can be used selectively for assignment. (*BRAKE \pm , *ALARM \pm , *READY \pm , *ZSPD \pm , INPOS \pm , TLMT \pm , VLMT \pm , INSPD \pm , WARN \pm , TGON \pm , INPOS \pm) *Basic allocation signal					
Analog Monitor			There are 2 input channels. Above 15 functions can be used selectively for assignment.					
Safety Function			2 Input Channels (STO1, STO2), 1 Output Channels (EDM \pm)					
USB Communication	Function		Firmware download, Parameter setting, Tuning, Secondary function, Parameter copy					
	Communication Standard		USB 2.0 Full Speed (applies standard)					
	Connect		PC or USB storing medium					
Internal Function	Dynamic Braking		Standard built-in brake (activated when the servo alarm goes off or when the servo is off).					
	Regenerative Braking		Both the default built-in brake and an externally installed brake are possible.					
	Display Function		7 segments(5DIGIT)					
	Self-setting Function		The [MODE] key changes the content displayed in 7 segments					
	Additional Function		Auto gain tuning function					
Protection Function			Overcurrent, overload, overvoltage, insufficient voltage, main power input problem, control power input problem, overspeed, motor cable, overheat(power module overheat, abnormal drive operation's temp), encoder problem, over-regenerative, sensor problem, communication problem					
Environment	Temperature		0 ~ +50[°C] / -20~ +70[°C]					
	Humidity		Below 90[%]RH(avoid dew-condensation)					
	Environment		Indoor, Avoid corrosive, inflammable gas or liquid, and electrically conductive dust.					

XDL-L7NHA001U ~ XDL-L7NHA004U [Weight : 1.0kg]

*Unit [mm]

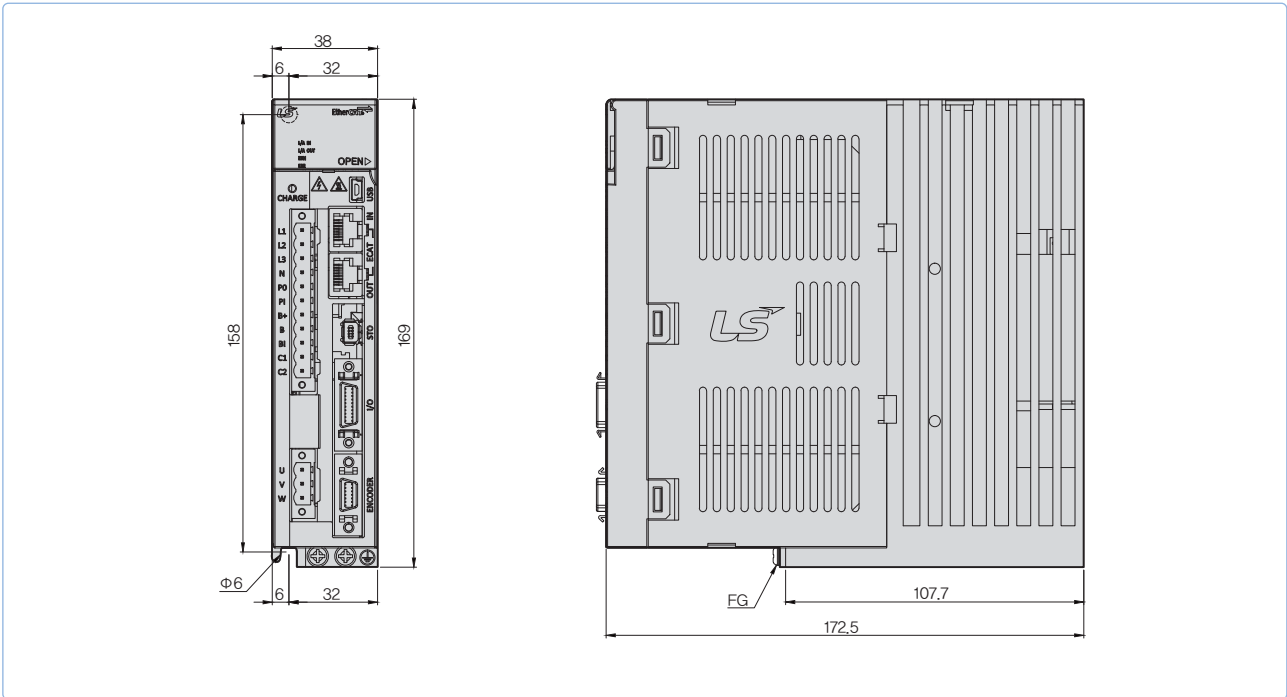

XDL-L7NHA008U / XDL-L7NHA010U [Weight : 1.5kg (Fan-Cooling included)]

*Unit [mm]

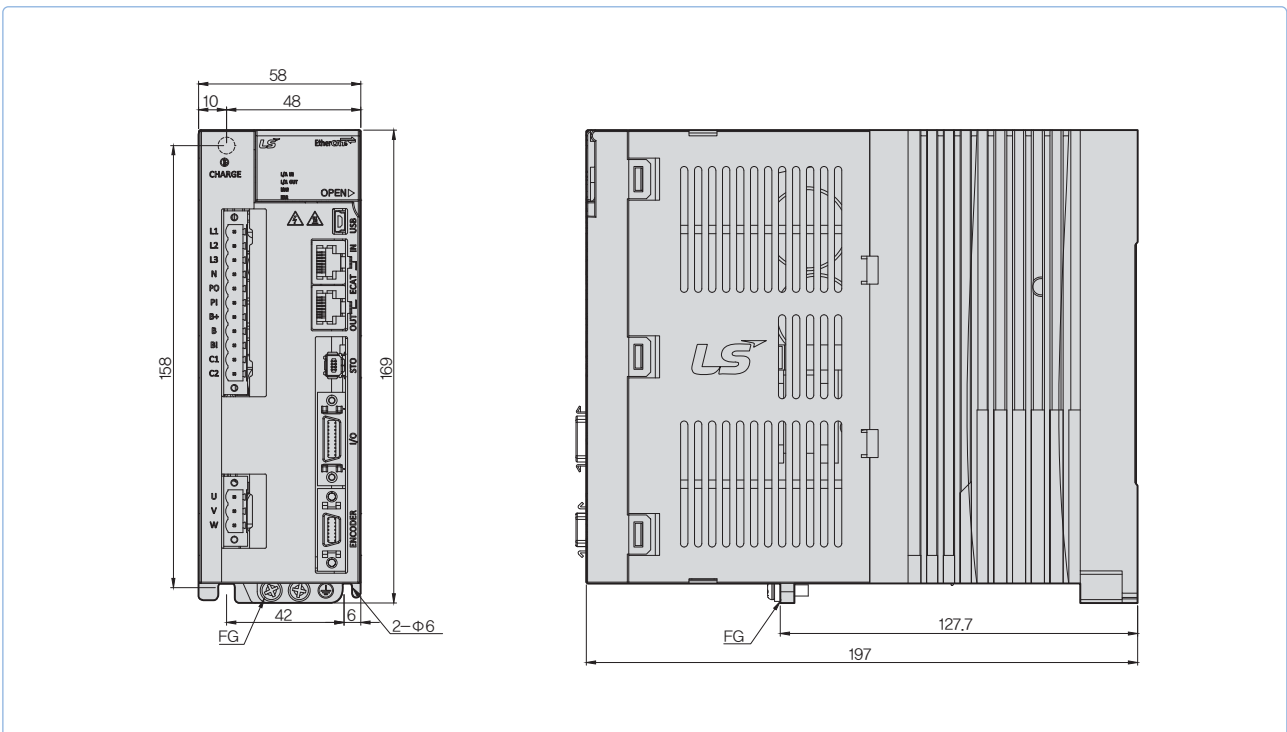

XDL-L7NHA020U / XDL-L7NHA035U[Weight : 2.5kg(Fan-Cooling included)]

*Unit [mm]

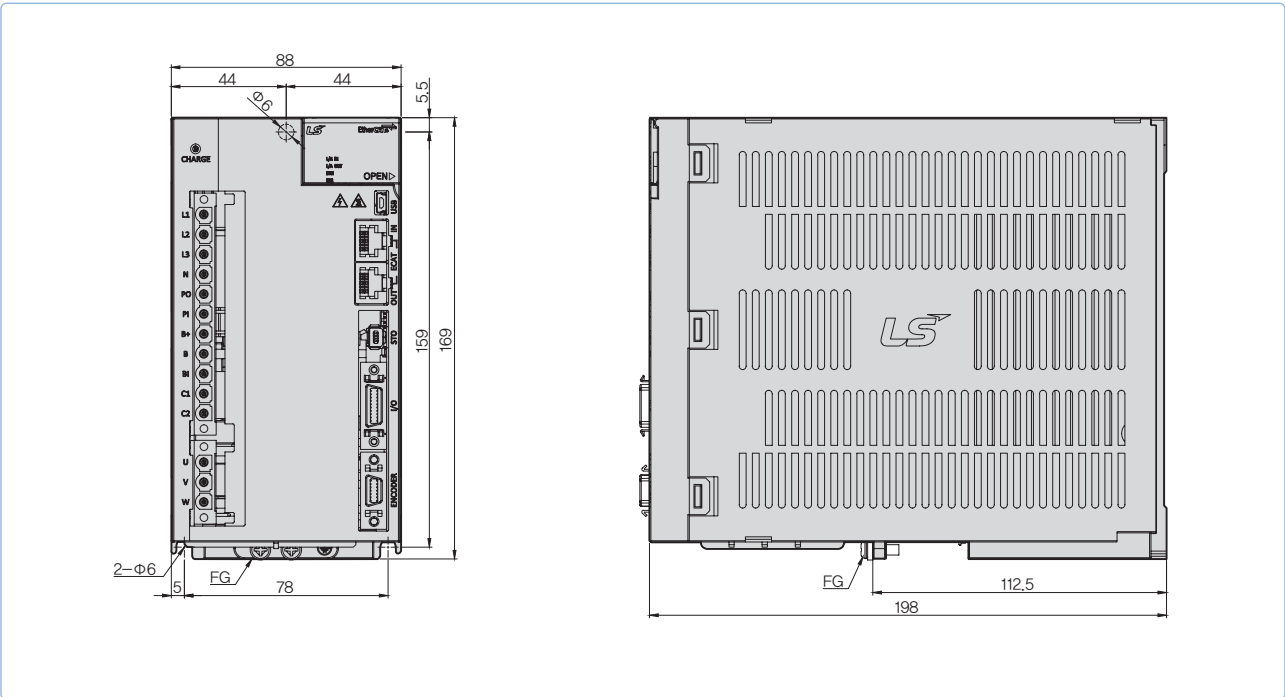

XDL-L7NHB010U[Weight : 1.5kg(Fan-Cooling included)]

*Unit [mm]

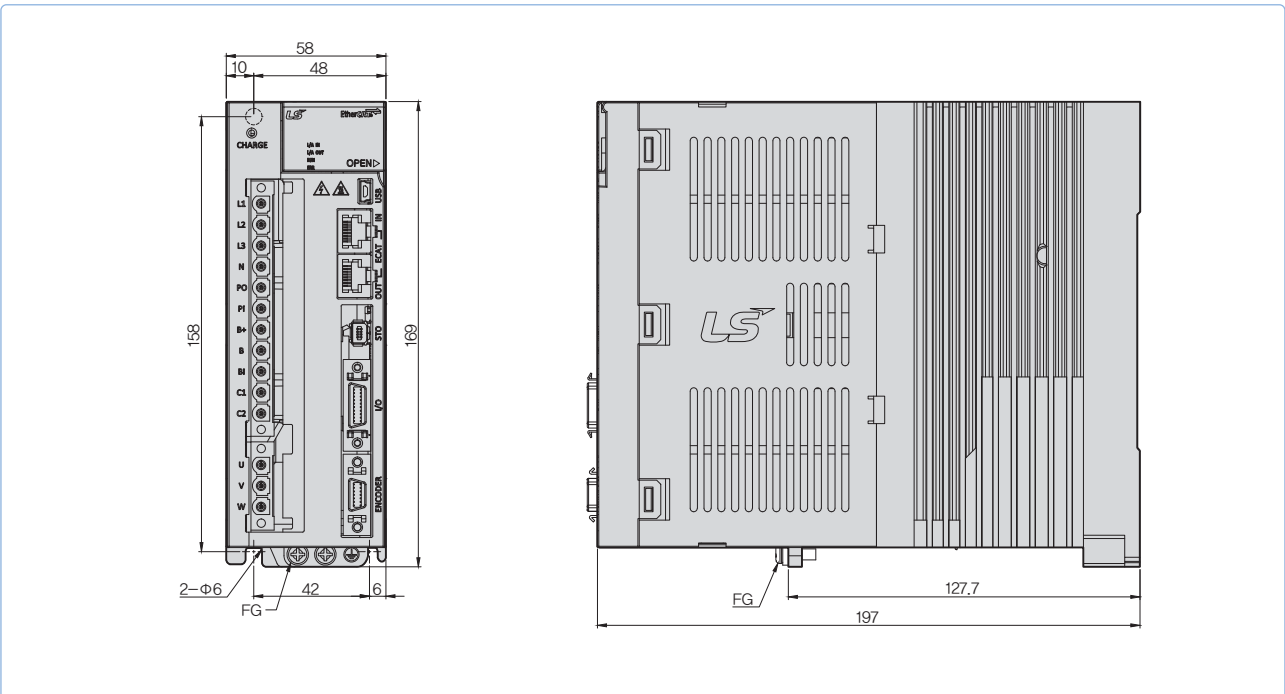

XDL-L7NHB020U / XDL-L7NHB035U [Weight : 2.5kg (Fan-Cooling included)]

*Unit [mm]

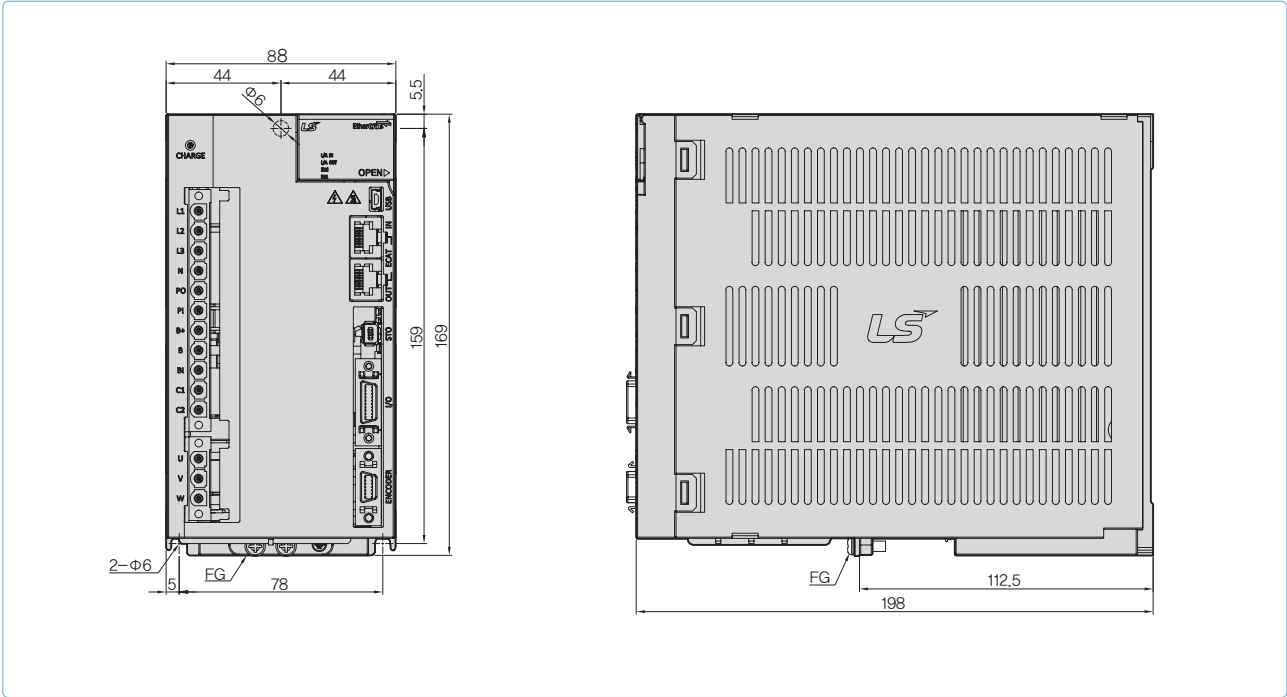

XDL-L7NB050U [Weight : 5.5kg (Fan-Cooling included)]

*Unit [mm]

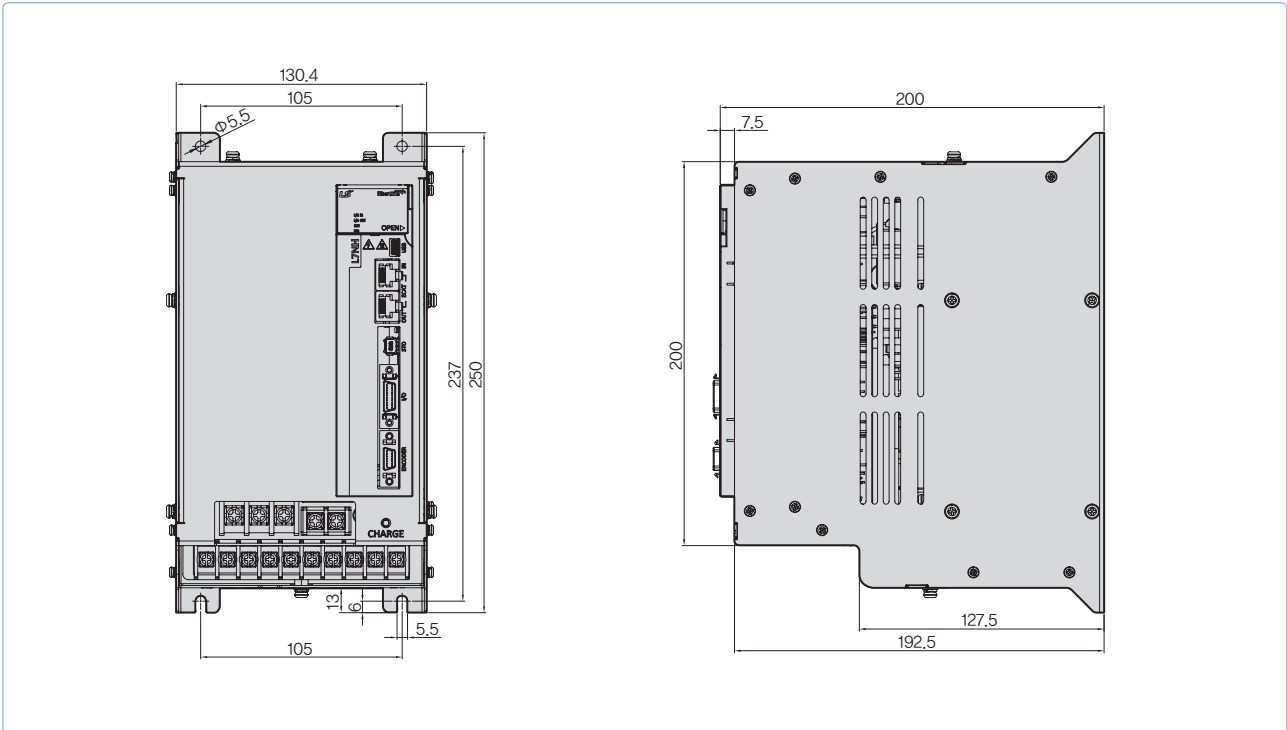

XDL-L7NHB075U[Weight : 8.5kg(Fan-Cooling included)]

*Unit [mm]

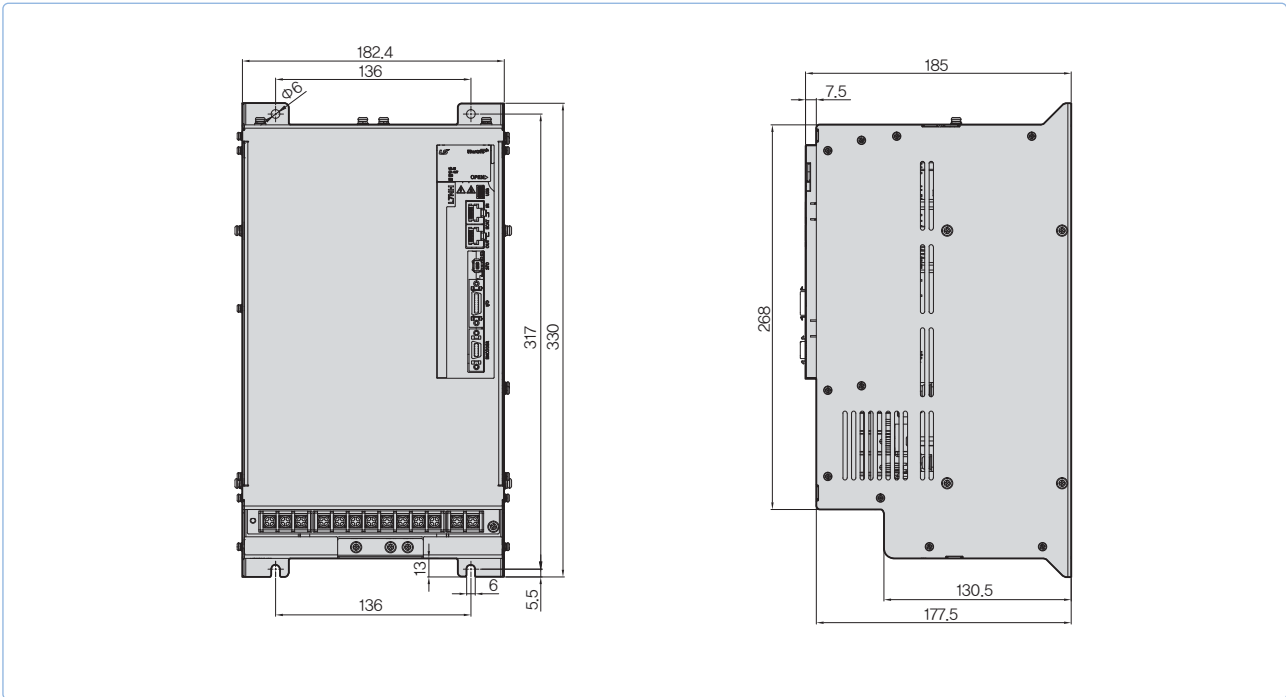

XDL-L7NHB150U[Weight : 15.5kg(Fan-Cooling included)]

*Unit [mm]

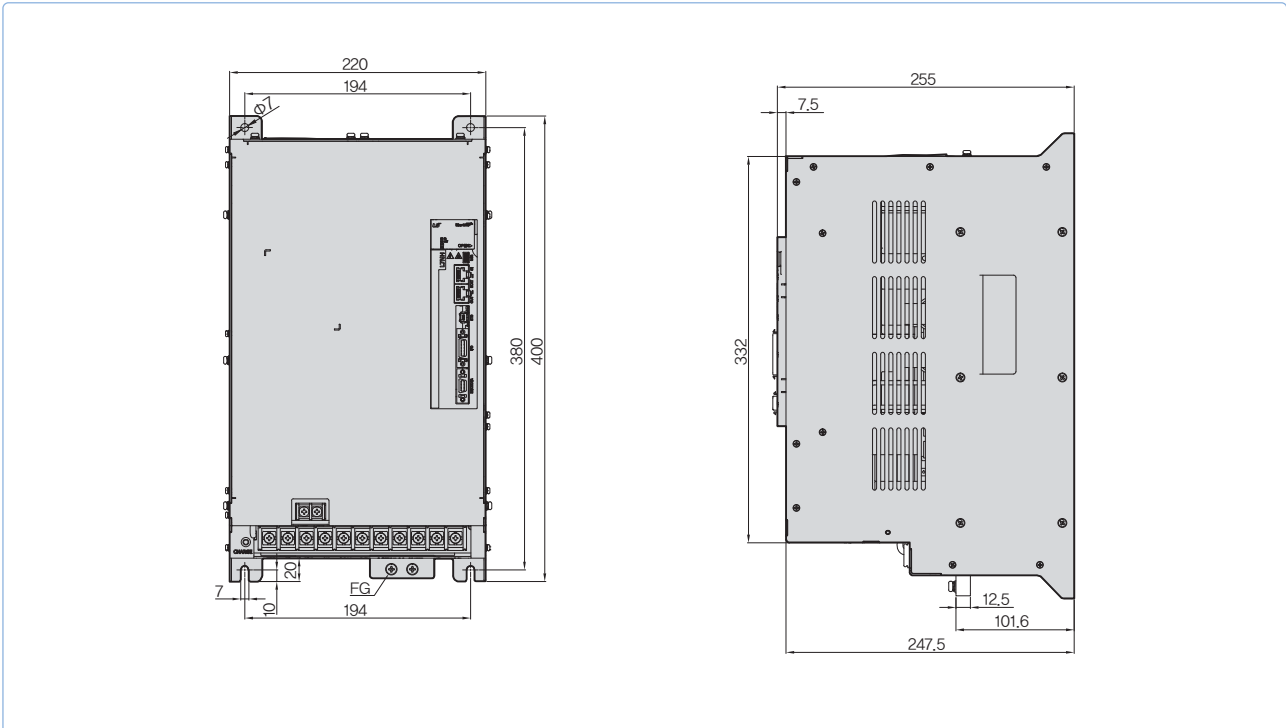

XDL-L7P Series



Servo Drive Designation

XDL	-	L7	P	A	004	B	AA
Model Name		Communication		Input Power Supply	Capacity	Encoder Type	Option
XDL Series		Stand I/O & Index Type		A:200VAC	001:100W 002:200W 004:400W 008:750W 010:1.0kW 020:2.0kW 035:3.5kW	U:Universal	Exclusive Option Code

Indexer Function Type **XDL-L7P**

Providing Program Function built-in single axis position determination module

- Supporting position control mode by pulse input
- Position control mode
- Possible to use without upper controller
- Modbus RTU Protocol (RS-422)

Support various motor and Encoder drive

- Supporting Rotary, DD and Motor drive (supporting 3rd party motor)
- Quadrature, BiSS-C, Tamagawa serial abs, EnDat 2.2, Resolver

Improved Control Performance

- Improved Control bandwidth
- Providing 4-step Notch-Filter
- Vibration control by Real-time FET
- Real-time gain tuning function

- 1 Display
- 2 Status LED
- 3 Charge Lamp
- 4 Main Power Connector (L1, L2, L3)
- 5 DC Reactor Connector(P0, PI) Short-Circuit When Not used
- 6 Regenerative Resistor Connector (B+, B, BI)
 - Short-Circuit B, BI terminals when standard type
 - Use B+, B terminals when using external resistor
- 7 Control Power connector (C1, C2)
- 8 Motor power connector(U, V, W)
- 9 Connector for analogue monitor
- 10 Switch for nod address setting
- 11 USB connector (USB)
- 12 RS-422 communication connector (CN3, CN4)
- 13 Control signal connector (I/O)
- 14 Encoder Connector (ENCODER)
- 15 Ground

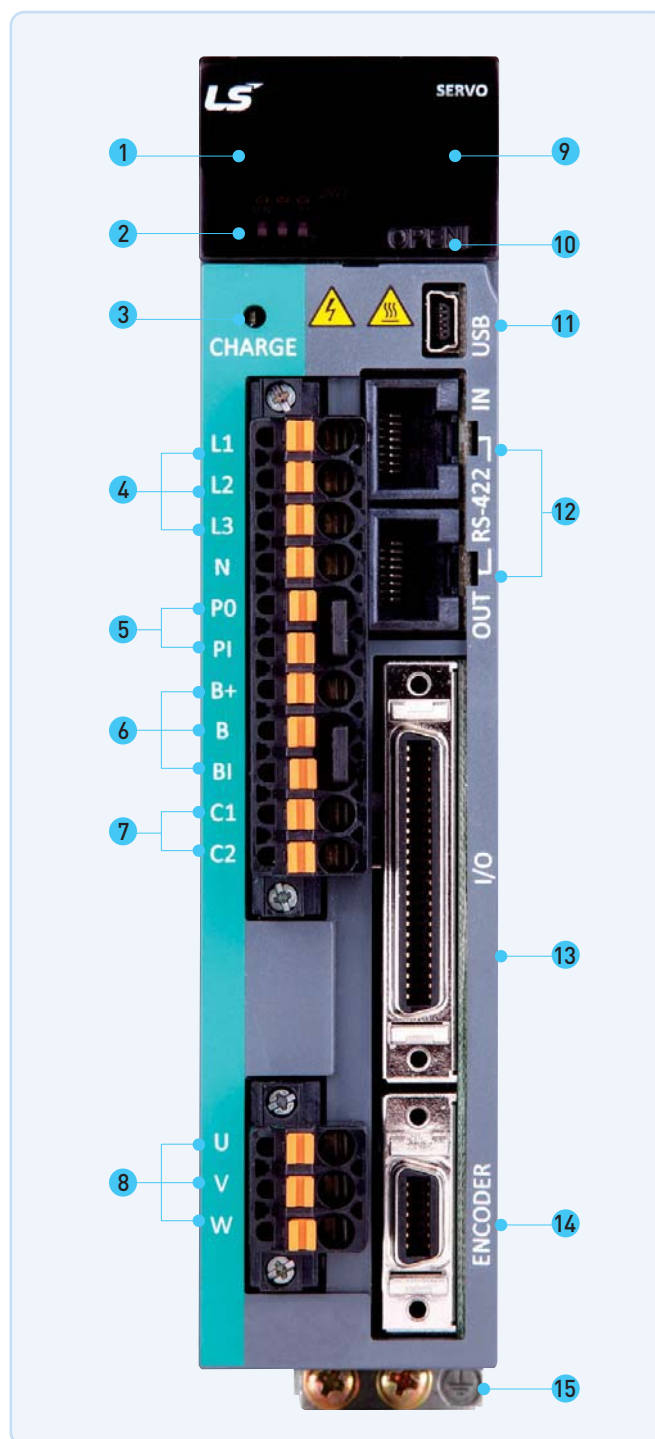

XDL-L7P Incremental Type

Rated Speed (rpm)	Maximum Speed (rpm)	Flange Size	Applicable Motor	Applicable Drive	Standard Encoder Type	Encoder Cable	Power Cable									
					Quadrature Type	INC	For power	Power + Brake	Brake							
3,000	5,000	□40	SAR3A	L7PA001U	* 2,048P/R	XLCS-E□□□AS	XLCS-P□□□GS		XLCS-P□□□KB							
		□40	SAR5A	L7PA001U												
		□40	SA01A	L7PA001U												
		□40	SA015A	L7PA002U												
		□60	SB01A	L7PA002U												
		□60	SB02A	L7PA002U												
		□60	SB04A	L7PA004U												
		□80	SC04A	L7PA004U												
		□80	SC06A	L7PA008U												
		□80	SC08A	L7PA008U												
		□80	SC10A	L7PA010U												
		□130	SE09A	L7PA008U												
		□130	SE15A	L7PA020U												
		□130	SE22A	L7PA020U												
2,000	3,000	□80	SC03D	L7PA004U	* 3,000P/R	XLCS-E□□□AS	XLCS-P□□□GS	XLCS-P□□□NB	XLCS-P□□□KB							
		□80	SC05D	L7PA008U												
		□80	SC06D	L7PA008U												
		□80	SC07D	L7PA008U												
		□130	SE06D	L7PA008U												
		□130	SE11D	L7PA010U												
		□130	SE16D	L7PA020U												
		□130	SE22D	L7PA020U												
		□180	SF22D	L7PA020U												
		□180	LF35D	L7PA035U												
		□220	SG22D	L7PA020U												
		□220	LG35D	L7PA035U												
		1,500	3,000	□130						SE05G	L7PA008U	* 3,000P/R	XLCS-E□□□BS	XLCS-P□□□HS	XLCS-P□□□NB	XLCS-P□□□PB
				□130						SE09G	L7PA010U					
□130	SE13G			L7PA020U												
□130	SE17G			L7PA020U												
2,700	3,000		□180	SF20G	L7PA035U	* 3,000P/R	XLCS-P□□□IS	XLCS-P□□□IS	XLCS-P□□□PB	XLCS-P□□□SB						
			□220	SG20G	L7PA020U											
			□220	LG30G	L7PA035U											
1,000	2,000	□130	SE03M	L7PA004U	* 3,000P/R	XLCS-E□□□BS	XLCS-P□□□HS	XLCS-P□□□NB	XLCS-P□□□PB							
		□130	SE06M	L7PA008U												
		□130	SE09M	L7PA010U												
		□130	SE12M	L7PA020U												
		□180	SF12M	L7PA020U												
		□180	SF20M	L7PA035U												
	1,700	2,000	□180	LF30M						L7PA035U	* 3,000P/R	XLCS-P□□□IS	XLCS-P□□□IS	XLCS-P□□□PB	XLCS-P□□□SB	
			□220	SG12M						L7PA020U						
			□220	SG20M						L7PA035U						
			□220	LG30M						L7PA035U						
3,000	3,500	□60	HB01A	L7PA002U	* 1,048P/R	XLCS-E□□□AS	XLCS-P□□□GS									
		□60	HB02A	L7PA002U												
		□60	HB04A	L7PA004U												
		□130	HE09A	L7PA008U												
		□130	HE15A	L7PA020U												
3,000	3,500	□60	HB01A	L7PA002U	* 2,048P/R	XLCS-E□□□BS	XLCS-P□□□HS									
		□60	HB02A	L7PA002U												
		□60	HB04A	L7PA004U												
		□130	HE09A	L7PA008U												
		□130	HE15A	L7PA020U												

XDL-L7P Serial Type

Rated Speed (rpm)	Maximum Speed (rpm)	Flange Size	Applicable Motor	Applicable Drive	Standard Encoder Type	Encoder Cable		Power Cable		
					Serial Type	Serial	Abs	For power	Power + Brake	Brake
3,000	5,000	□40	FALR5A	L7PA001U	* 18Bit Serial / M-Turn Abs	XLCS-E□□□ES	XLCS-E□□□ES1	XLCS-P□□□LS	XLCS-P□□□QS	
		□40	FAL01A	L7PA001U						
		□40	FAL015A	L7PA002U						
		□60	FBL01A	L7PA001U						
		□60	FBL02A	L7PA002U						
		□60	FBL04A	L7PA004U						
		□80	FCL04A	L7PA004U						
		□80	FCL06A	L7PA008U						
		□80	FCL08A	L7PA008U						
		□80	FCL10A	L7PA010U						
		□60	FB01A	L7PA001U				XLCS-P□□□FS	XLCS-P□□□QS	
		□60	FB02A	L7PA002U						
		□60	FB04A	L7PA004U						
		□80	FC04A	L7PA004U						
		□80	FC06A	L7PA008U						
		□80	FC08A	L7PA008U						
		□80	FC10A	L7PA010U						
		□130	FE09A	L7PA010U						
		□130	FE15A	L7PA020U						
		□130	FE22A	L7PA020U						
□130	FE30A	L7PA035U	XLCS-P□□□HS	XLCS-P□□□NB						
□180	FF30A	L7PA035U								
□130	FE03D	L7PA004U								
□130	FE15A	L7PA020U								
2,000	3,000	□80	FCL05D	L7PA008U	* 19Bit Serial / M-Turn Abs	XLCS-E□□□ES	XLCS-E□□□ES1	XLCS-P□□□LS	XLCS-P□□□QS	
		□80	FCL06D	L7PA008U						
		□80	FCL07D	L7PA008U						
		□80	FC03D	L7PA004U						
		□80	FC05D	L7PA008U						
		□80	FC06D	L7PA008U						
		□80	FC07D	L7PA008U						
		□130	FE06D	L7PA008U						
		□130	FE11D	L7PA010U				XLCS-P□□□HS	XLCS-P□□□NB	
		□130	FE16D	L7PA020U						
		□130	FE22D	L7PA020U						
		□180	FF22D	L7PA020U						
		□180	FF35D	L7PA035U						
		□220	FG22D	L7PA020U						
		□220	FG35D	L7PA035U						
		□130	FE05G	L7PA008U						
□130	FE09G	L7PA010U								
□130	FE13G	L7PA020U								
□130	FE17G	L7PA020U								
1,500	3,000	□180	FF20G	L7PA020U	XLCS-E□□□DS	XLCS-E□□□DS1	XLCS-P□□□IS	XLCS-P□□□PB	XLCS-P□□□SB	
		□180	FF30G	L7PA035U						
	2,700	□220	FG20G	L7PA020U						
	2,700	□220	FG30G	L7PA035U						
1,000	2,000	□130	FE03M	L7PA004U			XLCS-P□□□HS	XLCS-P□□□NB		
		□130	FE06M	L7PA008U						
		□130	FE09M	L7PA010U						
		□130	FE12M	L7PA020U						
		□180	FF12M	L7PA020U						
		□180	FF20M	L7PA020U						
	1,700	□180	FF30M	L7PA035U			XLCS-P□□□IS	XLCS-P□□□PB	XLCS-P□□□SB	
	2,000	□220	FG12M	L7PA020U						
		□220	FG20M	L7PA020U						
	1,700	□220	FG30M	L7PA035U						

Servo Drive

XDL-L7PA Drive

Item		Type Name	XDL-L7PA001U	XDL-L7PA002U	XDL-L7PA004U	XDL-L7PA008U	XDL-L7PA010U	XDL-L7PA020U	XDL-L7PA035U
Input Power	Main Power Supply	3 Phase AC200 ~ 230[V](-15 ~ +10[%]), 50 ~ 60[Hz]							
	Control Power Supply	Single Phase AC200 ~ 230[V](-15 ~ +10[%]), 50 ~ 60[Hz]							
Rated Current[A]			1.4	1.7	3.0	5.2	6.75	13.5	16.7
Peak Current[A]			4.2	5.1	9.0	15.6	20.25	40.5	50.1
Encoder Type		Quadrature(Incremental) BiSS-B, BiSS-C(Absolute, Incremental) Tamagawa Serial(Absolute, Incremental) EnDat 2.2							
Control Performance	Speed Control Range	Maximum 1: 5000							
	Frequency Response	Maximum 1 [kHz] or above (When using 19bit Serial Encoder)							
	Speed Variation Ratio	±0.01 [%] or lower [when load changes between 0 and 100%] ±0.1[%] or lower [temperature 25 ±10°C]							
	Accel/Decel Time	Straight or S-curve acceleration/deceleration [0~10,000[ms], 0~1,000[ms] Unit configurable]							
	Input Frequency	1[Mpps], line drive / 200[kpps], Open Collector							
	Input Pulse Type	Symbol + Pulse Series, CW+CCW, A/B Phase							
RS422 Communication Specifications	Communication Specifications	ANSI/TIA/EIA-422 Standard Specifications							
	Communication Protocol	MODBUS-RTU							
	Connector	RJ45 x 2							
	Synchro Method	Asynchronous							
	Transmission Speed	9600 /19200/38400/57600 [bps] Can be configured at [0x3002]							
	Transmission Distance	Maximum 200 [m]							
	Power Consumption	100[mA]							
	Terminating Resistance	Dip S/W(On/Off), Built-In 120 Ω							
Input/Output Signal	Digital Input	Input voltage range: DC 12[V] ~ DC 24[V] Total 16 input channel (allocatable) 32 function inputs can be selectively allocated (*SV_ON, *POT, *NOT, *A-RST, *START, *STOP, *REGT, *EMG, *HOME, *HSTART, *ISEL0, *ISEL1, *ISEL2, *ISEL3, *ISEL4, *ISEL5, PCON, GAIN2, P_CL, N_CL, MODE, PAUSE, ABSRQ, JSTART, JDIR, PCLR, AOV, SPD1/LVFS1, SPD2/LVFS2, SPD3, PROBE1, PROBE2) * Basic allocation signal.							
	Digital Output	Use rating: DC 24[V] ±10%, 120[βA] Total 8 input channel (allocatable) 19 function inputs can be selectively allocated (*ALARM±, *READY±, *BRAKE±, *INPOS1±, *ORG±, *EOS±, *TGON±, *TLMT±, VLMT±, INSPD±, ZSPD±, WARN±, INPOS2±, IOU0±, IOU1±, IOU2±, IOU3±, IOU4±, IOU5±) * Standard Allocation signal							
Analog Input/output	Analog input	Total 2 channels analog speed override input(-10[V] ~ +10[V]) analog torque command input(-10[V] ~ +10[V])							
	Analog output	Total 2 channels 15 function inputs can be selectively allocated							
USB Communication	Protection	Firmware download, parameter setting, tuning, auxiliary function, parameter copy							
	Communication Specifications	Complies with USB 2.0 Full Speed Specifications							
	Connection Device	PC or USB storage media							
Built-in functions	Dynamic Braking	Standard built-in(activated by servo alarm or servo OFF)							
	Regenerative Braking	Built-in, external brake attachable							
	Display	7 Segment(5 DIGIT)							
	Setting Function	Drive node address can be set using rotary switch							
	Additional Function	Gain tuning, alarm history, JOG operation, origin search							
	Protective Function	Excessive current, overload, excessive current limit, overheating, excessive voltage, low voltage, excessive speed, encoder fail, position following fail, current sensing fail							
Environment	Temperature	0 ~ 50[°C] / -20 ~ 65°C							
	Humidity	Below 90[%]RH[avoid dew-condensation]							
	Environment	Indoor, Avoid corrosive, inflammable gas or liquid, and electrically conductive dust.							

External Dimensions

**XDL-L7PA001U ~
XDL-L7PA004U
[Weight : 1.0kg
(Fan-Cooling included)]**

*Unit [mm]

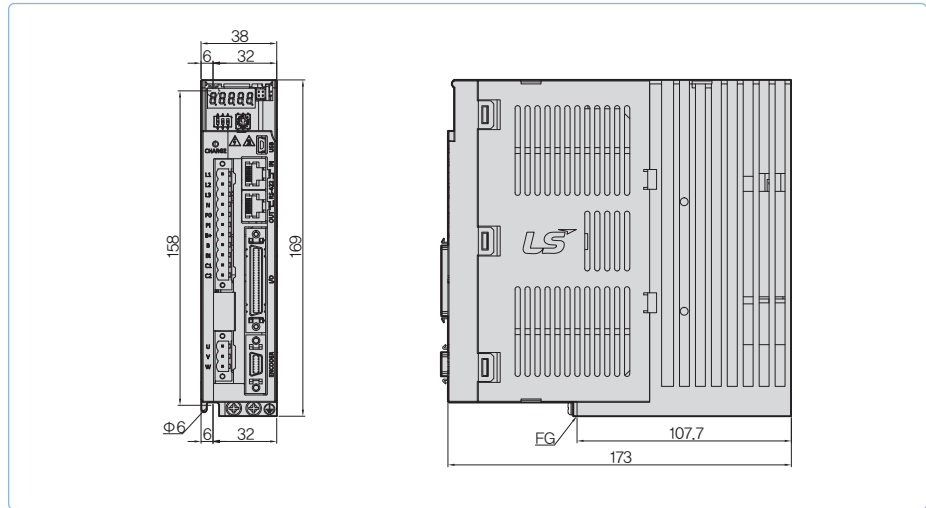

**XDL-L7PA008U /
XDL-L7PA010U
[Weight : 1.5kg
(Fan-Cooling included)]**

*Unit [mm]

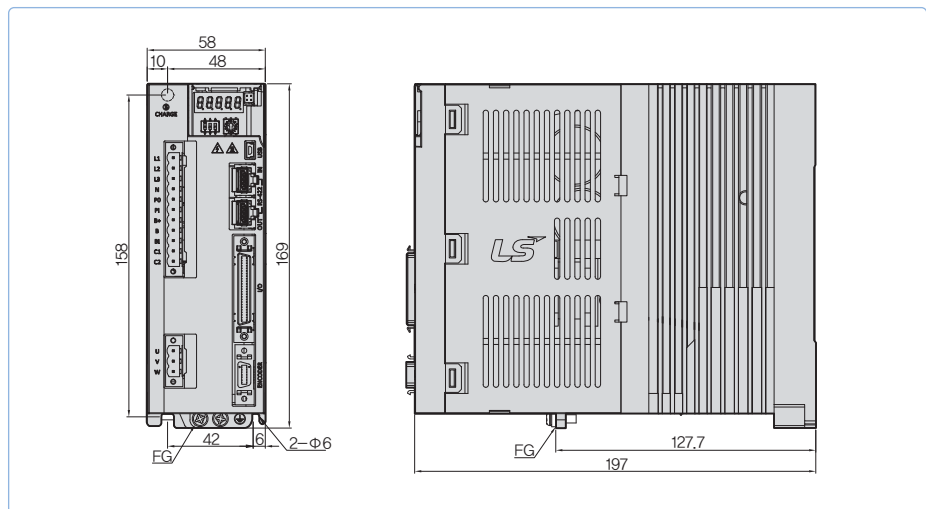

**XDL-L7PA020U /
XDL-L7PA035U
[Weight : 2.5kg
(Fan-Cooling included)]**

*Unit [mm]

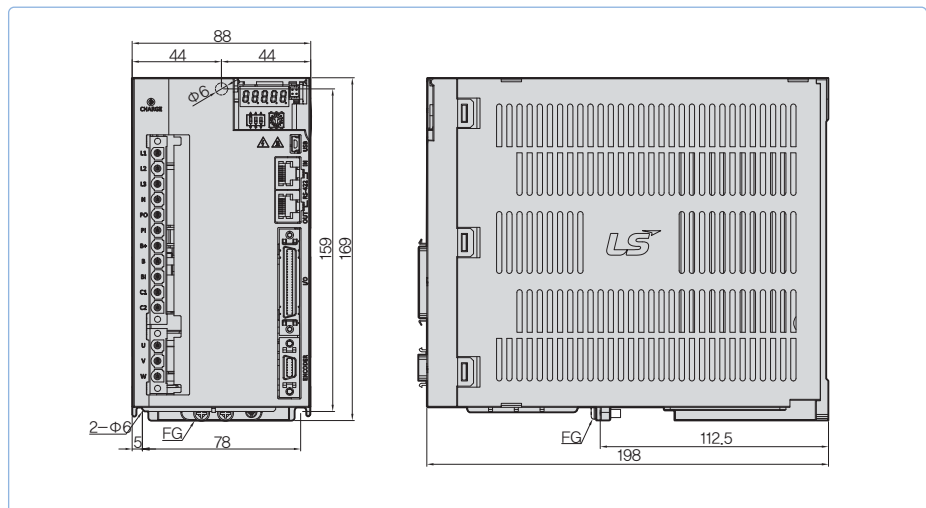

XIP(PEGASUS) Series



Servo Drive Designation

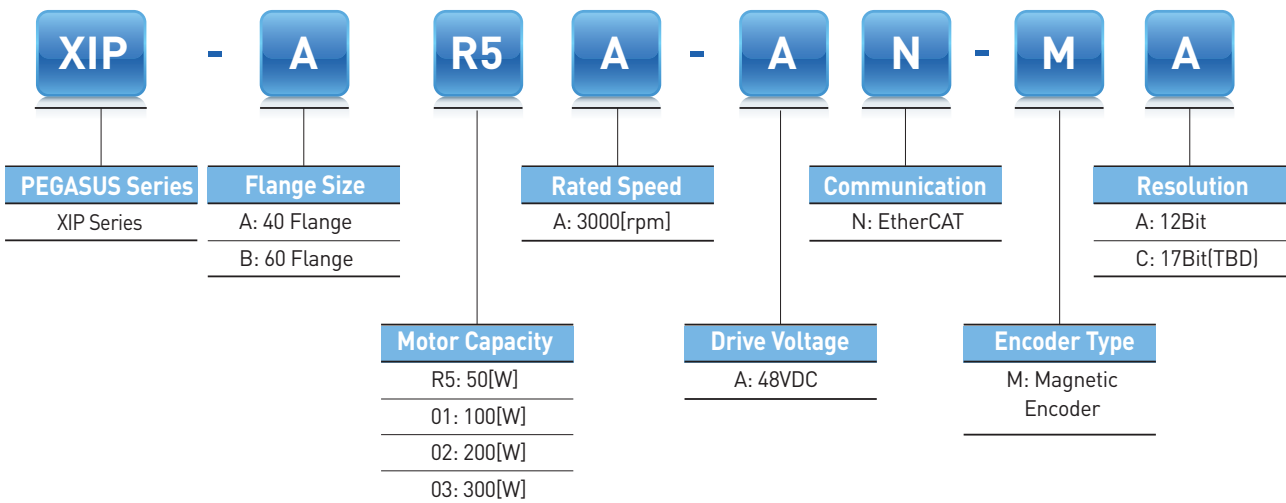

Integrated Servo System Type **XIP(PEGASUS)**

Enhanced efficiency integrated servo system

- Cost effective from installation by integrated system of motor, encoder cable and drive
- Maximization for useful space when installed at limited and small space
- High effectiveness for application of multi axis because there is no limitation for space of installation

Real-time control through EtherCAT

- High speed, Real-time capability and Synchronization mechanism
- Improved EtherCAT communication speed
- Supporting CoE, EoE and FoE

- ① Input / Output Signal Connector (CN1)
 - This Connector is for Sequence Input / Output Signals
- ② EtherCAT Communication Output Port (OUT)
- ③ Status LED
 - It Indicates the current state of EtherCAT Communication
- ④ Power Connector (CN3)
- ⑤ EtherCAT Communication Input Port (IN)
- ⑥ Safety Connector (CN2)
 - This Connector connects Safety Devices
- ⑦ USB Connector (CN5, Mini B type)
 - This Connector is to Communicate With a PC
- ⑧ Node Address Setting Switch
 - This Switch is to set the node address of the drive
 - You can set the node addresses from 0 to 15



Rated Values of Servo Drive

Rated	□40 50W	□40 100W	□60 100W	□60 200W	□60 300W
Continuous output current [Arms]	1.77	2.38	3.62	5	6.8
Maximum output current [Arms]	3.54	3.75	7.24	10	13.6
Input voltage	DC 48V ~ DC 60V				

Basic Specifications

Category		Details	
Use conditions	Control method	PWM controlled sine wave current driving method	
	Operating temperature/storage temperature	0~+40[°C] / -20~+60[°C]	
	Operating humidity/storage humidity	Below 80% RH / Below 90% RH (no freeze or condensation)	
	Vibration-/impact-resistance	TBD	
	Degree of protection/degree of pollution	TBD	
	Altitude	1000m or lower	
	Other	To be free from electrostatic noise, strong electrolysis, or radiation.	
Performance	Speed variation	Load variation	At 0 to 100% load: ± 3% (at rated speed)
		Voltage variation	Rated voltage ±10%: 0% (at rated speed)
		Temperature variation	25°C: ±0.1% or less (at rated speed)
Input/output signal	Input signal	Input voltage range: DC 12 V - DC 30 V The 4-channel input signal can be assigned to 12 functions: POT, NOT, HOME, STOP, PCON, GAIN2, PCL, NCL, PROBE1, PROBE2, EMG, and ARST.	
	Output signal	Rated voltage and current: DC 24 V ± 10%, 120 [mA] The 2-channel output signal can be assigned to 11 functions: BRAKE, ALARM, RDY, ZSPD, INPOS1, TLMT, VLMT, INSPD, WARN, TGON, and INPOS2.	
Analog Monitor		Number of channels: 1, Output voltage range: ±4V, Angular resolution: 12 bits, Stabilization time: 15 us	
USB communication	Connecting device	PC or USB storage medium	
	Communication standard	Conform to the USB 2.0 Full Speed Standard.	
	Function	Firmware download, parameter setting, adjustment, auxiliary functions, and parameter copy function.	
Dynamic brake (three-phase short-circuit)		Activates when servo alarm, servo OFF, or Emergency stop (POT, NOT and EMG) is input.	
Protection functions		Overcurrent, overload, current limit, overheat, overvoltage, undervoltage, overspeed, encoder error, position follow error, ect.	
Auxiliary functions		Gain adjustment, alarm history, JOG drive, programmed JOG drive, etc.	
Safety functions	Input	STO1 and STO2	
	Compatible standard	TBD	

EtherCAT Communication Specification

Category		Details
Communication standard	FoE	Firmware download
	EoE	Parameter setting, adjustment, auxiliary functions, and parameter copy through UDP.
	CoE	IEC 61158 Type12, IEC 61800-7 CiA 402 drive profile
Physical layer		100BASE-TX(IEEE802.3)
Connector		RJ45 x 2
Distance		Within 100 m between nodes
DC (Distributed Clock)		Sync by DC mode
LED Display		• L/A0(Link/Act IN) • L/A1(Link/Act OUT) • RUN • ERR
Cia402 drive Profile		Supports CSP, CSV, CST, PP, PV, PT, and HM Modes.

Encoder Specification

Category	Details
Encoder Type	Magnetic Encoder (12bit)

Motor Specification

Model	Unit	□40 50W	□40 100W	□60 100W	□60 200W	□60 300W
Rated Torque	[Kgf cm]	1.62	3.25	3.25	6.50	9.74
Max. Torque	[Kgf cm]	3.24	4.88	6.50	13.0	19.48
Rated Speed	[rpm]	3000	2400	3000	3000	3000
Max Speed	[rpm]	3000	3000	3000	3000	3000
Inertia	[Kg m ² x 10 ⁻⁴]	0.0240	0.0450	0.114	0.182	0.321

XIP-AR5A

*Unit [mm]

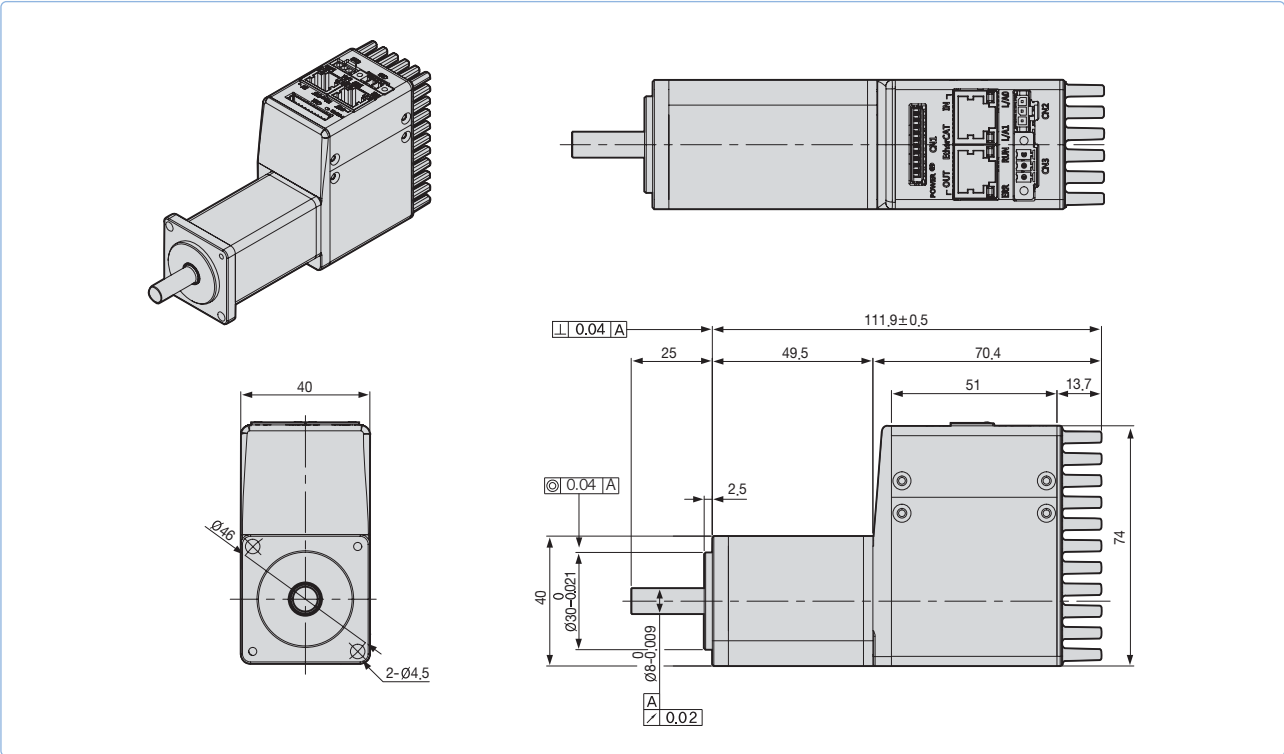

XIP-A01A

*Unit [mm]

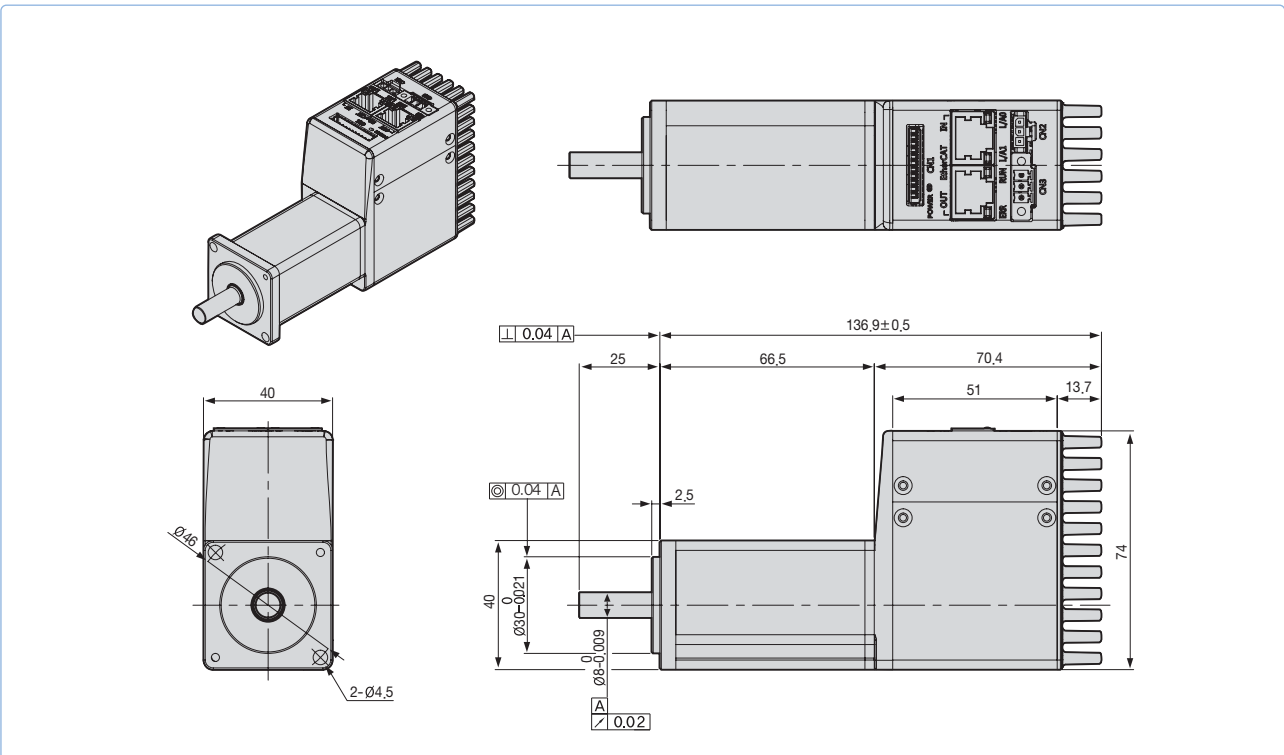

XIP-B01A

*Unit [mm]

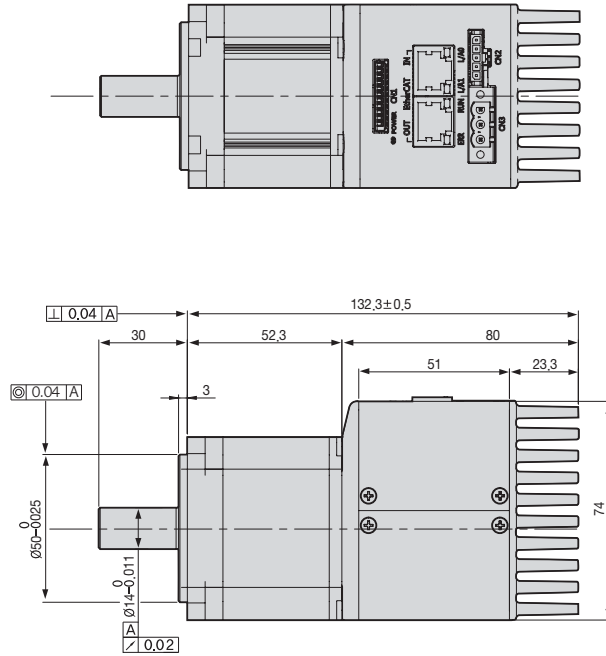
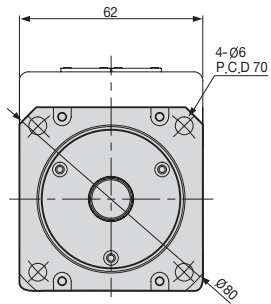
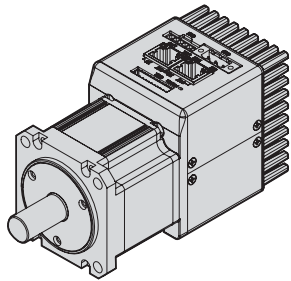

XIP-B02A

*Unit [mm]

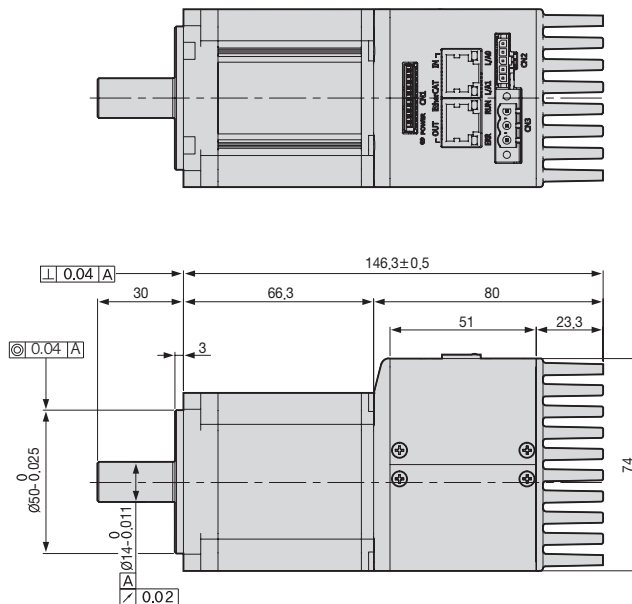
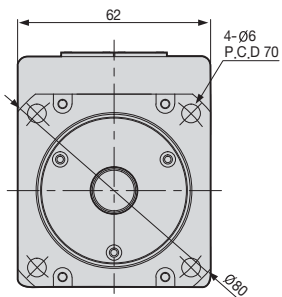
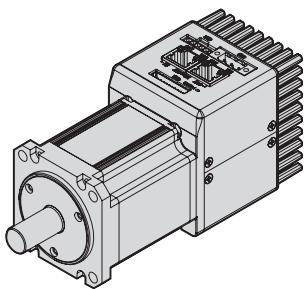

XIP-B03A

*Unit [mm]

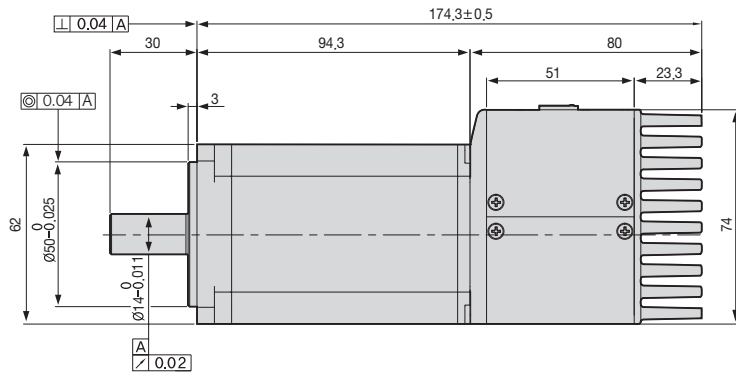
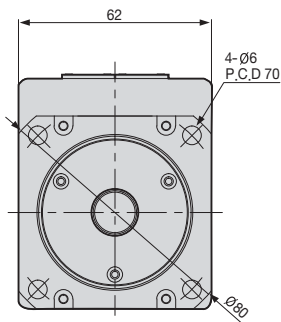
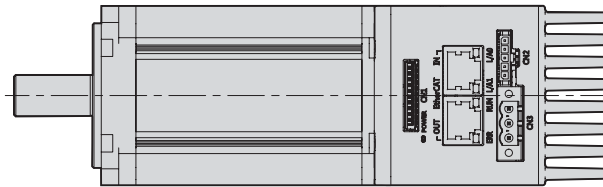
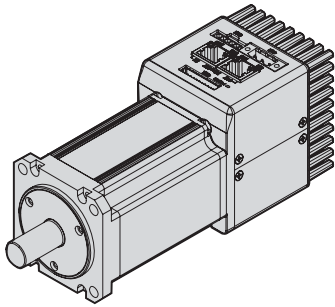

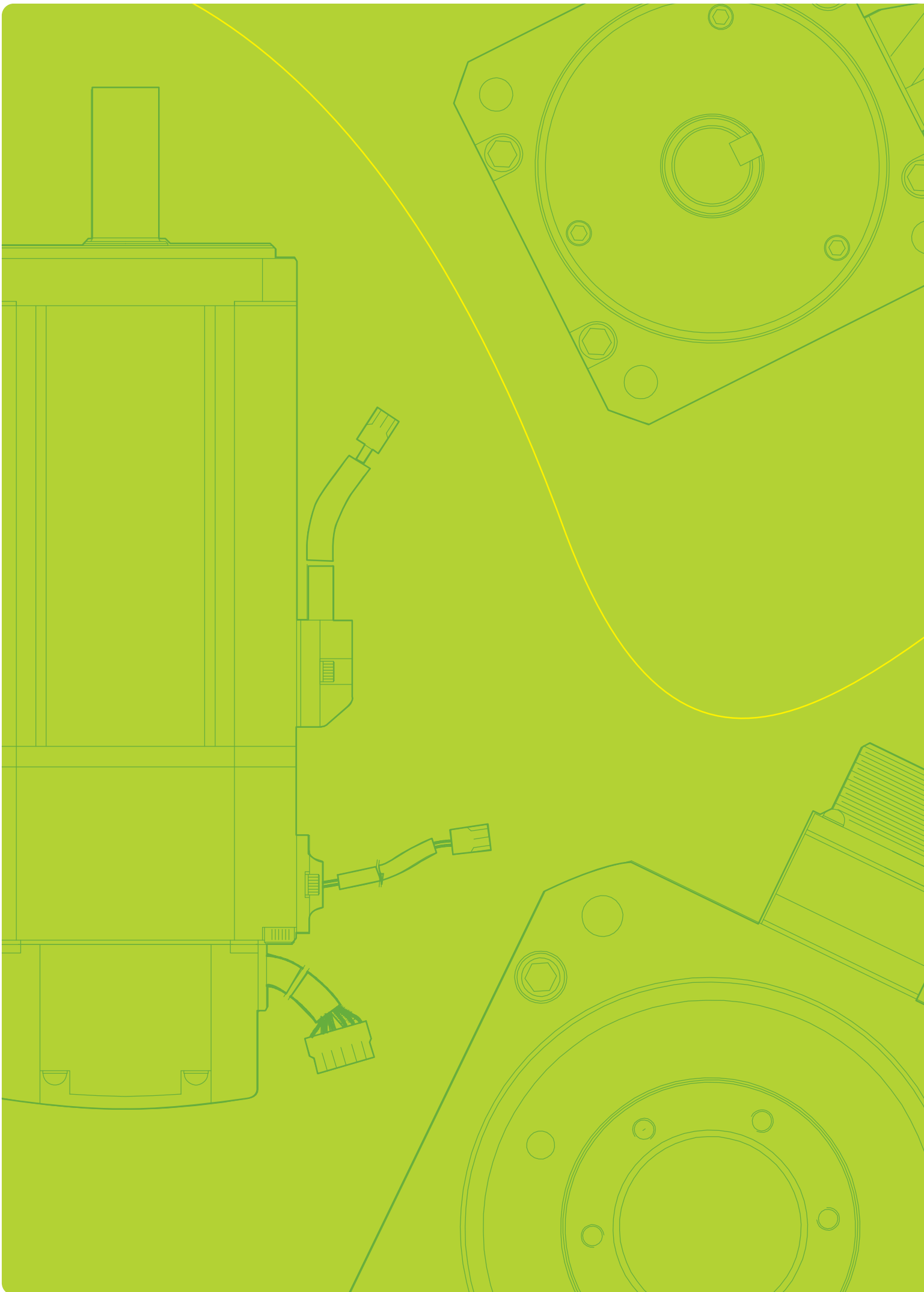

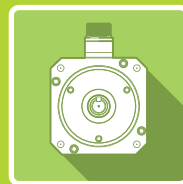

Servo Motor

Contents

S Series

Solid/Hollow Shaft Type Rotating Servo Motor ----- 60

F Series

Flat Type Rotating Servo Motor ----- 76

MDM Series

Direct-Drive Motor ----- 91

Servo Motor Designation

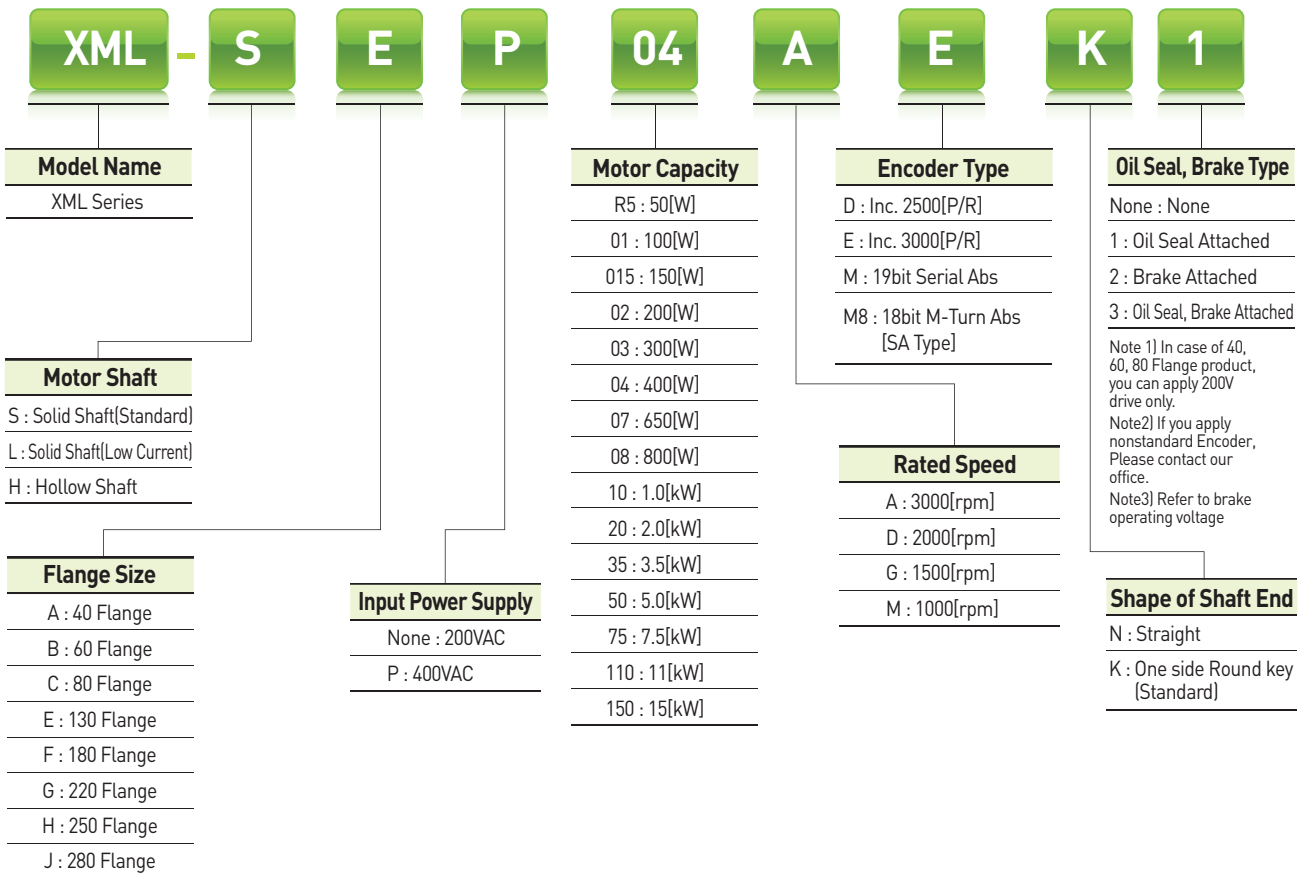

Motor Specifications [Rated 3000r/min]

Servo Motor (XML-□□□□)		SAR5A	SA01A	SA015A	SB01A	SB02A	SB04A	SC04A	SC06A	SC08A	SC10A
Applicable Drive (L7□A□□)		L7□A001			L7□A002		L7□A004		L7□A008		L7□A010
Flange Size(□)		□40			□60		□60		□80		
Rated Output	[kW]	0.05	0.1	0.15	0.1	0.2	0.4	0.4	0.6	0.8	1
	[N · m]	0.16	0.32	0.48	0.32	0.64	1.27	1.27	1.91	2.55	3.19
Rated Torque	[kgf · cm]	1.62	3.25	4.87	3.25	6.49	12.99	12.99	19.49	25.98	32.48
	[N · m]	0.48	0.96	1.43	0.96	1.91	3.82	3.82	5.73	7.64	9.56
Max. Instantaneous	[kgf · cm]	4.87	9.74	14.62	9.74	19.48	38.96	38.96	58.47	77.95	97.43
	[A]	1.2	1.38	1.73	1.65	1.63	2.89	2.82	3.58	4.83	5.37
Rated Current	[A]	3.6	4.14	5.19	4.95	4.89	8.67	8.46	10.74	14.49	16.11
Rated Speed	[r/min]	3000									
Max. Speed	[r/min]	5000									
Inertia	[kg · m ² × 10 ⁻⁴]	0.02	0.05	0.06	0.11	0.18	0.32	0.67	1.09	1.51	1.93
	[gf · cm · s ²]	0.02	0.05	0.07	0.12	0.19	0.33	0.69	1.11	1.54	1.97
Allowable Load Inertia Ratio		30 times of motor inertia			20 times of motor inertia		15 times of motor inertia				
Rated Power Rate	[kW/s]	10.55	23.78	35.34	8.89	22.26	50.49	24.05	33.39	43.02	52.57
Speed/Position Detector	Standard <small>Note1</small>	Quad.Type Incremental 2048[P/R]			Quad.Type Incremental 3000[P/R]						
	Option	Serial Type 18[Bit]			Serial Type 19[Bit]						
Specifications & Features	Structure	Fully closed · Self cooling IP55 <small>Note1</small>					Fully closed · Self cooling IP65 <small>Note1</small>				
	Rated Time	Continuous									
	Ambient Temp	Operating : 0 ~ 40[°C] Storage : -10 ~ 60[°C]									
	Ambient Humidity	20 ~ 80[%] (avoid dew-condensation)									
	Atmosphere	Avoid direct sunlight, no corrosive gas, inflammable gas, oil mist, or dust.									
	E/V	Elevation/vibration 49[m/s ²][5G]									
Weight	[kg]	0.38	0.5	0.7	0.82	1.08	1.58	1.88	2.52	3.15	3.80

Note1) Except for axis penetration, when you attach reducer to the motor, we don't guarantee IP for reducer. If you bend over specification designated in cable standard, it is difficult to guarantee IP marked. It can be satisfied protection grade when you use private cable only.

Speed-Torque Characteristics

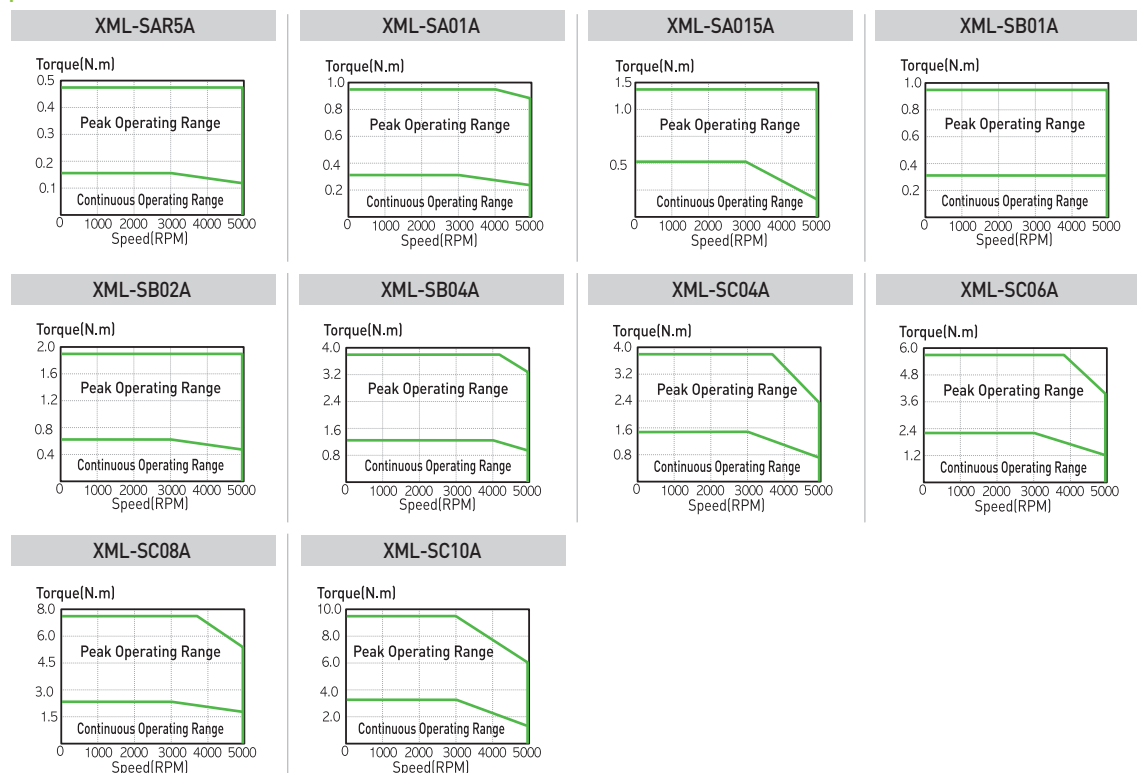

Motor Specifications [Rated 3000r/min]

Servo Motor (XML-□□□□)		SE09A	SE15A	SE22A	SE30A	SF30A	SF50A	HB01A	HB02A	HB04A	HE09A	HE15A	HE30A
Applicable Drive (L7□A□□)		L7□A008	L7□A020	L7□A050	L7□A035	L7□A050	L7□A002	L7□A004	L7□A008	L7□A020	L7□A050	L7□A008	L7□A050
Flange Size(□)		□130			□180		□60			□130			
Rated Output	[kW]	0.9	1.5	2.2	3	3	5	0.1	0.2	0.4	0.9	1.5	3
Rated Torque	[N · m]	2.86	4.77	7	9.55	9.55	15.91	0.32	0.64	1.27	2.86	4.77	9.55
	[kgf · cm]	29.23	48.72	71.45	97.43	97.43	162.38	3.25	6.49	12.99	29.23	48.72	97.43
Max. Instantaneous	[N · m]	8.59	14.32	21.01	28.64	28.64	47.74	0.96	1.91	3.82	8.59	14.32	28.64
	[kgf · cm]	87.69	146.15	214.35	292.29	292.29	487.15	9.74	19.48	38.96	87.69	146.15	292.29
Rated Current	[A]	4.95	8.23	11.98	17.16	16.7	27.4	1.65	1.63	2.89	4.95	8.23	17.16
Max.Current	[A]	14.85	24.69	35.94	51.48	50.1	82.2	4.95	4.89	8.67	14.85	24.69	51.48
Rated Speed	[r/min]	3000											
Max. Speed	[r/min]	5000						3500			3500		
Inertia	[kg · m ² X10 ⁻⁴]	6.66	12	17.34	22.68	30.74	52.13	0.27	0.33	0.46	19.56	22.27	31.81
	[gf · cm · s ²]	6.8	12.24	17.69	23.14	31.37	53.19	0.27	0.34	0.47	19.96	22.72	32.46
Allowable Load Inertia Ratio		10 times of motor inertia				5 times of motor inertia		20 times of motor inertia			10 times of motor inertia		
Rated Power Rate	[kW/s]	12.32	18.99	28.28	40.20	29.66	48.58	3.34	11.98	34.47	4.10	10.01	22.03
Speed/Position Detector	Standard Note1	Quad. Type Incremental 3000[P/R]						Quad.Type Incremental 1024[P/R]			Quad.Type Incremental 2048[P/R]		
	Option	Serial Type 19[Bit]						X					
Specifications & Features	Structure	Fully closed · Self cooling IP65 Note1						Fully closed · Self cooling IP55 Note1					
	Rated Time	Continuous											
	Ambient Temp	Operating : 0 ~ 40[°C] Storage : -10 ~ 60[°C]											
	Ambient Humidity	90[%]RH Below [avoid dew-condensation]											
	Atmosphere	Avoid direct sunlight, no corrosive gas, inflammable gas, oil mist, or dust.											
	E/V	Elevation/vibration 49[m/s ²][5G]											
Weight	[kg]	5.5	7.5	9.7	11.8	12.4	17.7	0.9	1.2	1.7	5.8	7.4	

Note1 Except for axis penetration, when you attach reducer to the motor, we don't guarantee IP for reducer. If you bend over specification designated in cable standard, it is difficult to guarantee IP marked. It can be satisfied protection grade when you use private cable only.

Speed-Torque Characteristics

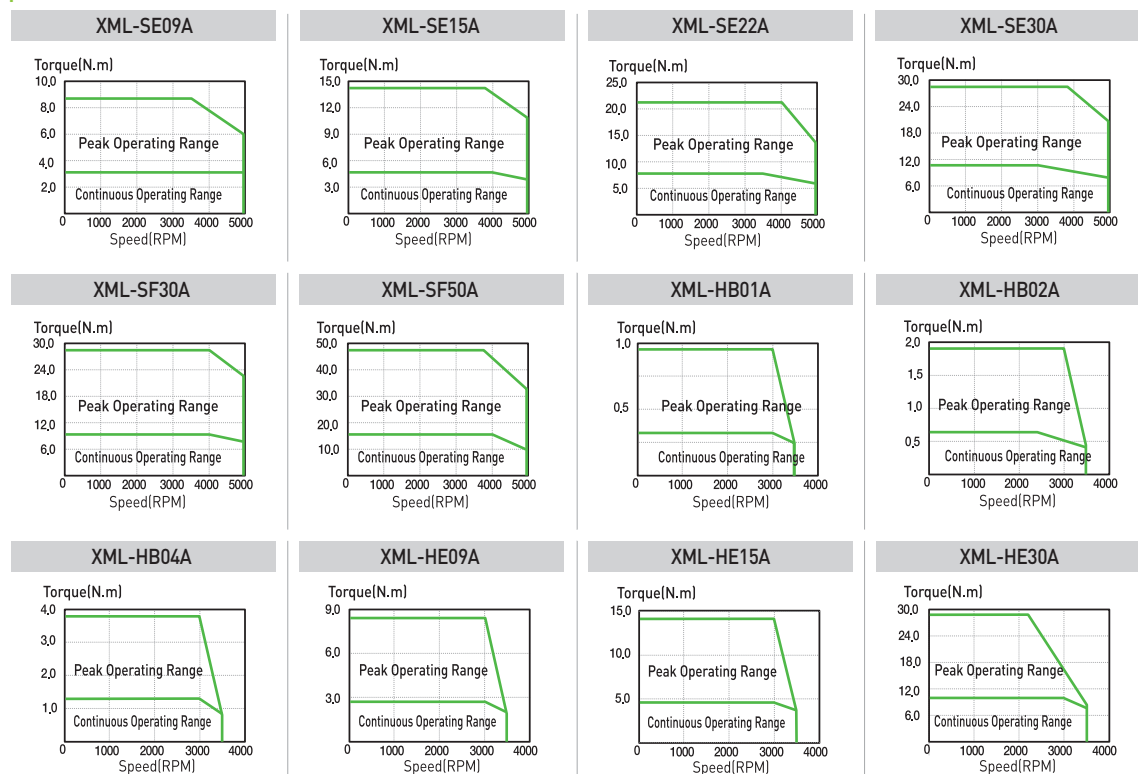

Motor Specifications [Rated 2000r/min]

Servo Motor (XML-□□□□)		SC03D	SC05D	SC06D	SC07D	SE06D	SE11D	SE16D	SE22D	
Applicable Drive (L7□A□□)		L7□A004	L7□A008			L7□A008	L7□A010	L7□A020		
Flange Size(□)		□80				□130				
Rated Output	[kW]	0.3	0.45	0.55	0.65	0.6	1.1	1.6	2.2	
	[N · m]	1.43	2.15	2.63	3.1	2.86	5.25	7.64	10.5	
Rated Torque	[kgf · cm]	14.61	21.92	26.79	31.66	29.23	53.59	77.94	107.17	
	[N · m]	4.3	6.45	7.88	9.31	8.59	15.75	22.92	31.51	
Max. Instantaneous	[kgf · cm]	43.84	65.77	80.38	94.99	87.69	160.76	233.83	321.52	
	[A]	2.59	3.23	3.82	4.42	3.97	6.28	9.23	12.37	
Max.Current	[A]	7.77	9.69	11.46	13.26	11.91	18.84	27.69	37.11	
Rated Speed	[r/min]	2000								
Max. Speed	[r/min]	3000								
Inertia	[kg · m ² × 10 ⁻⁴]	0.67	1.09	1.51	1.93	6.66	12	17.34	22.68	
	[gf · cm · s ²]	0.69	1.11	1.54	1.97	6.8	12.24	17.69	23.14	
Allowable Load Inertia Ratio		15 times of motor inertia				10 times of motor inertia				
Rated Power Rate	[kW/s]	30.43	42.27	45.69	49.97	12.32	22.98	33.65	48.64	
Speed/Position Detector	Standard Note1	Quad. Type Incremental 3000[P/R]								
	Option	Serial Type 19[Bit]								
Specifications & Features	Structure	Fully closed · Self cooling IP65 Note1								
	Rated Time	Continuous								
	Ambient Temp	Operating : 0 ~ 40[°C] Storage : -10 ~ 60[°C]								
	Ambient Humidity	90[%]RH Below [avoid dew-condensation]								
	Atmosphere	Avoid direct sunlight, no corrosive gas, inflammable gas, oil mist, or dust.								
	E/V	Elevation/vibration 49[m/s ²][5G]								
Weight	[kg]	1.9	2.5	3.2	3.9	5.5	7.5	9.7	11.8	

Note1) Except for axis penetration, when you attach reducer to the motor, we don't guarantee IP for reducer. If you bend over specification designated in cable standard, it is difficult to guarantee IP marked It can be satisfied protection grade when you use private cable only.

Servo Motor

Speed-Torque Characteristics

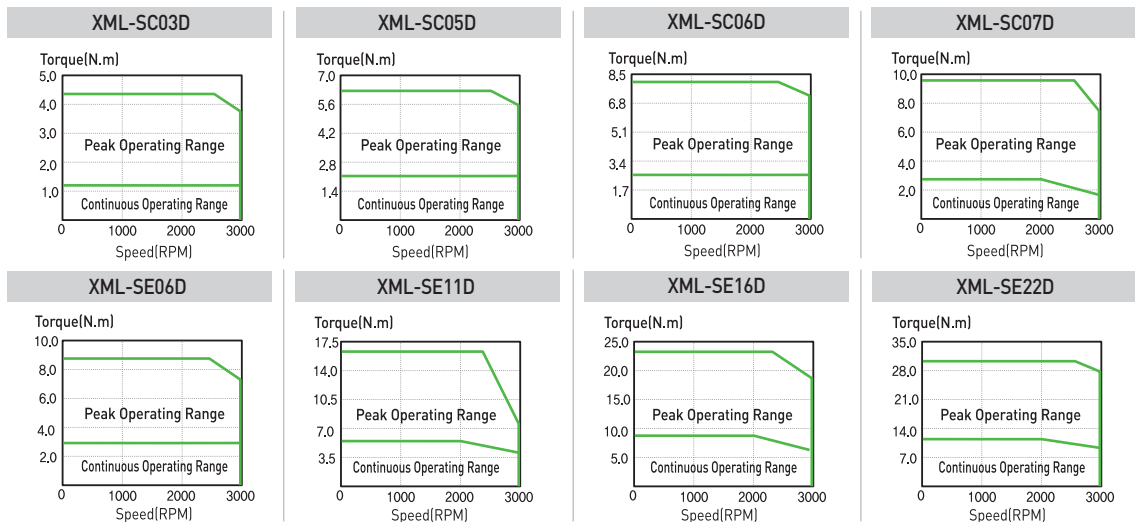

Motor Specifications [Rated 2000r/min]

Servo Motor (XML-□□□□)		SF22D	LF35D	SF55D	SF75D	SG22D	LG35D	SG55D	SG75D
Applicable Drive (L7□A□□)		L7□A020	L7□A035	L7□A050	L7□A075	L7□A020	L7□A035	L7□A050	L7□A075
Flange Size(□)		□ 180				□ 220			
Rated Output	[kW]	2.2	3.5	5.5	7.5	2.2	3.5	5.5	7.5
	[N · m]	10.5	16.71	26.26	35.81	10.5	16.71	26.26	35.81
Rated Torque	[kgf · cm]	107.17	170.5	267.93	365.36	107.2	170.52	267.9	365.4
	[N · m]	31.51	50.13	78.77	89.51	31.51	50.13	78.77	89.51
Max. Instantaneous	[kgf · cm]	321.52	511.51	803.8	913.41	321.52	511.51	803.8	913.4
	[A]	13.5	15.85	30.25	34.6	12.3	16.05	30.25	38
Rated Current	[A]	40.5	47.55	90.75	86.5	36.9	48.15	90.75	102
Rated Speed	[r/min]	2000							
Max. Speed	[r/min]	3000			2500	3000			2500
	[kg · m ² × 10 ⁻⁴]	30.74	52.13	83.6	121.35	51.42	80.35	132.41	172.91
Inertia	[gf · cm · s ²]	31.35	53.16	85.31	123.74	52.47	81.99	135.11	176.44
	Allowable Load Inertia Ratio	5 times of motor inertia							
Rated Power Rate	[kW/s]	35.88	53.56	82.56	105.75	21.45	34.75	52.07	74.15
Speed/Position Detector	Standard Note1	Quad. Type Incremental 3000[P/R]							
	Option	Serial Type 19[Bit]							
Specifications & Features	Structure	Fully closed · Self cooling IP65 Note1							
	Rated Time	Continuous							
	Ambient Temp	Operating : 0 ~ 40[°C] Storage : -10 ~ 60[°C]							
	Ambient Humidity	90[%]RH Below (avoid dew-condensation)							
	Atmosphere	Avoid direct sunlight, no corrosive gas, inflammable gas, oil mist, or dust.							
	E/V	Elevation/vibration 49[m/s ²][5G]							
Weight	[kg]	12.4	17.7	26.3	35.6	17	22	30.8	37.5

Note1) Except for axis penetration, when you attach reducer to the motor, we don't guarantee IP for reducer. If you bend over specification designated in cable standard, it is difficult to guarantee IP marked. It can be satisfied protection grade when you use private cable only.

Speed-Torque Characteristics

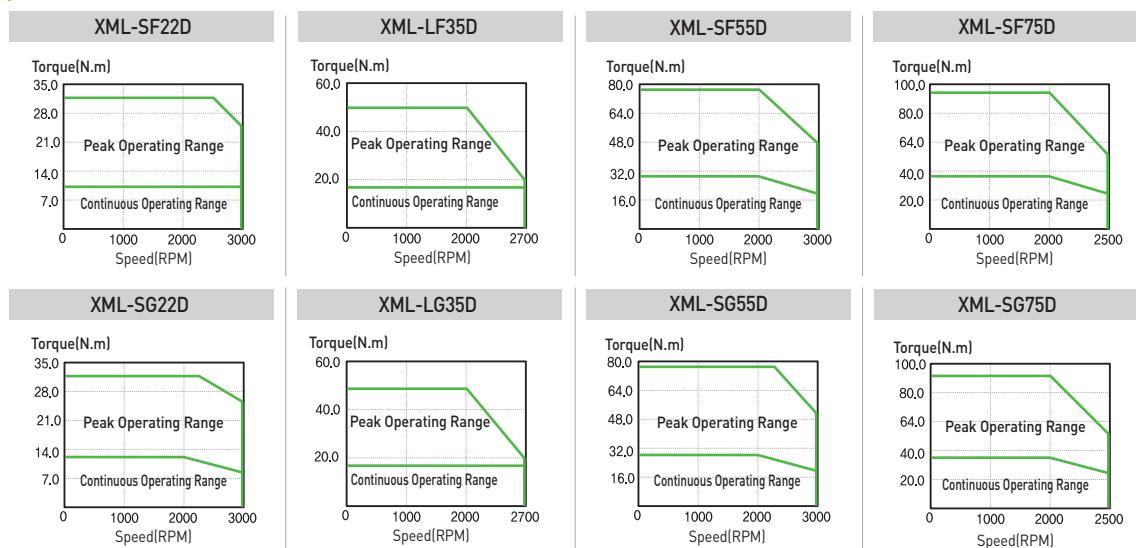

Motor Specifications [Rated 1500r/min]

Servo Motor (XML-□□□□)		SE05G	SE09G	SE13G	SE17G	SF20G	LF30G	SF44G	SF60G	SG20G	LG30G	SG44G	SG60G
Applicable Drive (L7□A□□)		L7□A008	L7□A010	L7□A020		L7□A035		L7□A050	L7□A075	L7□A020	L7□A035	L7□A050	L7□A075
Flange Size(□)		□130				□180				□220			
Rated Output	[kW]	0.45	0.85	1.3	1.7	1.8	2.9	4.4	6	1.8	2.9	4.4	6
	[N · m]	2.86	5.41	8.28	10.82	11.46	18.46	28.01	38.19	11.46	18.46	28.01	38.19
Rated Torque	[kgf · cm]	29.23	55.21	84.44	110.42	116.92	188.37	285.8	389.7	116.92	188.37	285.8	389.7
	[N · m]	8.59	16.23	24.83	32.46	34.37	55.38	84.02	95.48	34.47	55.38	84.02	95.48
Max. Instantaneous	[kgf · cm]	87.69	165.63	253.32	331.26	350.75	565.1	857.39	974.3	350.8	565.1	857.39	974.3
	[A]	3.97	6.47	10	12.75	14.7	15.92	31.75	38	13.1	16.19	31.5	38
Rated Current	[A]	11.91	19.41	30	38.25	44.1	47.64	95.25	102	39.3	48.57	94.5	102
Rated Speed	[r/min]	1500											
Max. Speed	[r/min]	3000				3000	2700	3000	2500	3000	2700	3000	2500
Inertia	[kg · m ² X 10 ⁻⁴]	6.66	12	17.34	22.68	30.74	52.13	83.6	121.35	51.42	80.35	132.41	172.91
	[gf · cm · s ²]	6.8	12.24	17.69	23.14	31.37	53.19	85.31	123.83	52.47	81.99	135.11	176.44
Allowable Load Inertia Ratio		10 times of motor inertia					5 times of motor inertia						
Rated Power Rate	[kW/s]	12.32	24.4	39.49	51.63	42.71	65.37	93.83	120.21	25.53	42.41	59.24	84.36
Speed/Position Detector	Standard Note1	Quad. Type Incremental 3000[P/R]											
	Option	Serial Type 19[Bit]											
Specifications & Features	Structure	Fully closed · Self cooling IP65 Note1											
	Rated Time	Continuous											
	Ambient Temp	Operating : 0 ~ 40[°C] Storage : -10 ~ 60[°C]											
	Ambient Humidity	90[%]RH Below [avoid dew-condensation]											
	Atmosphere	Avoid direct sunlight, no corrosive gas, inflammable gas, oil mist, or dust.											
	E/V	Elevation/vibration 49[m/s ²][5G]											
Weight	[kg]	5.5	7.5	9.7	11.8	12.4	17.7	26.3	35.6	17	22	30.8	37.52

Note1) Except for axis penetration, when you attach reducer to the motor, we don't guarantee IP for reducer. If you bend over specification designated in cable standard, it is difficult to guarantee IP marked It can be satisfied protection grade when you use private cable only.

Servo Motor

Speed-Torque Characteristics

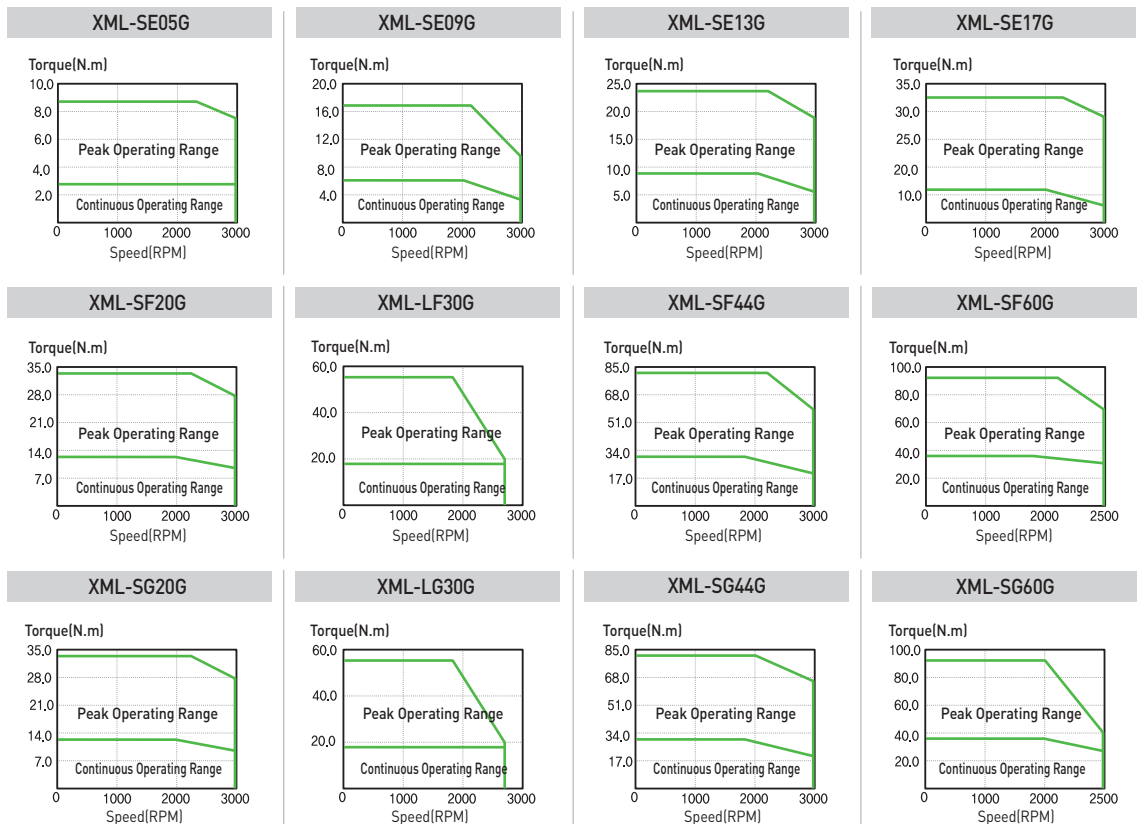

Motor Specifications [Rated 1000r/min]

Servo Motor [XML-□□□□]	SE03M	SE06M	SE09M	SE12M	SF12M	SF20M	LF30M	SF44M	SG12M	SG20M	LG30M	SG44M	SG60M	
Applicable Drive [L7□A□□]	L7□A004	L7□A008	L7□A010	L7□A020	L7□A035	L7□A050	L7□A020	L7□A035	L7□A050	L7□A035	L7□A050	L7□A075		
Flange Size[□]	□ 130				□ 180				□ 220					
Rated Output [kW]	0.3	0.6	0.9	1.2	1.2	2	3	4.4	1.2	2	3	4.4	6	
Rated Torque	[N · m]	2.86	5.73	8.59	11.46	11.46	19.1	28.64	42.01	11.46	19.1	28.64	42.01	57.29
	[kgf · cm]	29.23	58.46	87.69	116.92	116.92	194.86	292.29	428.69	116.92	194.86	292.29	428.69	584.6
Max. Instantaneous	[N · m]	8.59	17.19	25.78	34.37	34.37	57.29	85.93	126.04	34.37	57.29	85.93	126.04	171.87
	[kgf · cm]	87.69	175.3	263.06	350.75	350.75	584.58	876.88	1286.08	350.75	584.58	876.88	1286.08	1753.80
Rated Current [A]	2.51	4.15	5.78	7.63	8.4	14.4	15.99	31.24	8.87	15.02	16.04	31.83	38	
Max. Current [A]	7.53	12.45	17.34	22.89	25.2	43.2	47.97	93.72	26.61	45.06	48.12	95.49	102	
Rated Speed [r/min]	1000													
Max. Speed [r/min]	2000				1700			2000			1700		2000	
Inertia	[kg · m ² × 10 ⁻⁴]	6.66	12	17.34	22.68	30.74	52.13	83.6	121.35	51.42	80.35	132.41	172.91	291.36
	[gf · cm · s ²]	6.8	12.24	17.69	23.14	31.37	53.19	85.31	123.83	52.47	81.99	135.11	176.44	297.31
Allowable Load Inertia Ratio	10 times of motor inertia						5 times of motor inertia							
Rated Power Rate [kW/s]	12.32	27.35	42.59	57.89	42.71	69.95	98.15	145.45	25.53	45.39	61.97	102.08	112.65	
Speed/Position Detector	Standard Note1	Quad. Type Incremental 3000[P/R]												
	Option	Serial Type 19[Bit]												
Specifications & Features	Structure	Fully closed · Self cooling IP65 Note1												
	Rated Time	Continuous												
	Ambient Temp	Operating : 0 ~ 40[°C] Storage : -10 ~ 60[°C]												
	Ambient Humidity	90[%]RH Below (avoid dew-condensation)												
	Atmosphere	Avoid direct sunlight, no corrosive gas, inflammable gas, oil mist, or dust.												
	E/V	Elevation/vibration 49[m/s ²][5G]												
Weight [kg]	5.5	7.5	9.7	11.8	12.4	17.7	26.3	35.6	17	22	30.8	37.5	66.2	

Note1) Except for axis penetration, when you attach reducer to the motor, we don't guarantee IP for reducer. If you bend over specification designated in cable standard, it is difficult to guarantee IP marked. It can be satisfied protection grade when you use private cable only.

Speed-Torque Characteristics

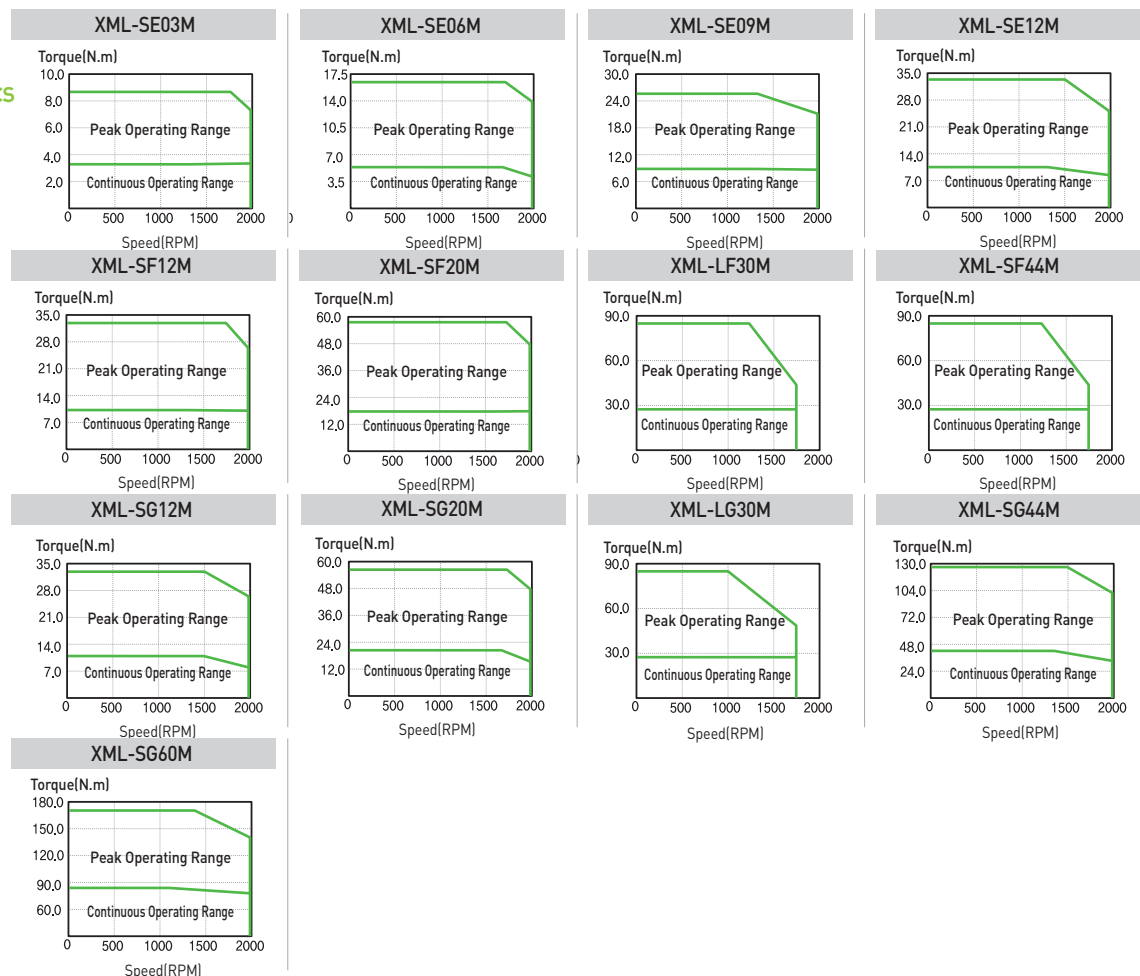

Motor Specifications [Rated 3000r/min]

Servo Motor (XML-□□□□)		SEP09A	SEP15A	SEP22A	SEP30A	SFP30A	SFP50A	
Applicable Drive (L7□A□□□)		L7□B010	L7□B020		L7□B035		L7□B050	
Flange Size(□)		□130				□180		
Rated Output	[kW]	0.9	1.5	2.2	3	3	5	
Rated Torque	[N · m]	2.86	4.77	7	9.55	9.55	15.92	
	[kgf · cm]	29.23	48.72	71.46	97.44	97.44	162.4	
Max. Instantaneous	[N · m]	8.59	14.32	21.01	28.65	28.65	39.79	
	[kgf · cm]	87.7	146.16	214.37	292.33	292.33	406.01	
Rated Current	[A]	2.97	4.89	7.17	9.78	9.37	15.49	
Max. Current	[A]	8.62	14.2	20.84	28.41	27.38	45.27	
Rated Speed	[r/min]	3000						
Max. Speed	[r/min]	5000						
Inertia	[kg · m ² X10 ⁻⁴]	6.659	11.999	17.339	22.679	30.74	52.13	
	[gf · cm · s ²]	6.795	12.244	17.693	23.142	31.367	53.194	
Allowable Load Inertia Ratio		10 times of motor inertia				5 times of motor inertia		
Rated Power Rate		[kW/s]	12.32	19.00	28.28	40.21	42.71	65.37
Speed/Position Detector	Standard Note1	Quad. Type Incremental 3000[P/R]						
	Option	Serial Type 19[Bit]						
Specifications & Features	Structure	Fully closed · Self cooling IP65 Note1						
	Rated Time	Continuous						
	Ambient Temp	Operating : 0 ~ 40[°C] Storage : -10 ~ 60[°C]						
	Ambient Humidity	90[%]RH Below (avoid dew-condensation)						
	Atmosphere	Avoid direct sunlight, no corrosive gas, inflammable gas, oil mist, or dust.						
	E/V	Elevation/vibration 49[m/s ²][5G]						
Weight	[kg]	5.5	7.54	9.68	11.78	12.4	17.7	

Note1) Except for axis penetration, when you attach reducer to the motor, we don't guarantee IP for reducer. If you bend over specification designated in cable standard, it is difficult to guarantee IP marked. It can be satisfied protection grade when you use private cable only.

Speed-Torque Characteristics

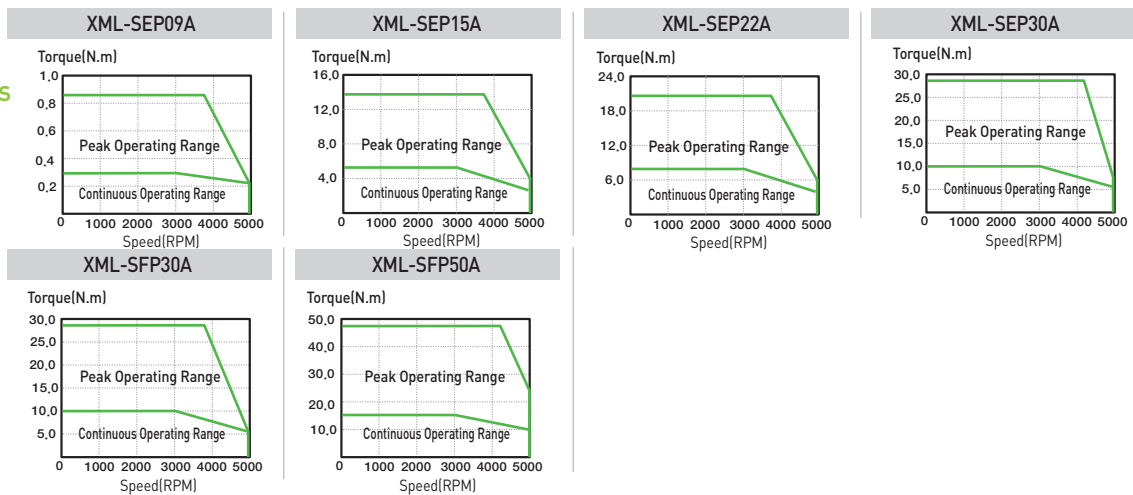

Servo Motor

Motor Specifications [Rated 2000r/min]

Servo Motor (XML-□□□□)	SEP06D	SEP11D	SEP16D	SEP22D	SFP22D	SFP35D	SFP55D	SFP75D	SGP22D	SGP35D	SGP55D	SGP75D	SGP110D	
Applicable Drive (L7□A□□)	L7□B010		L7□B020		L7□B035	L7□B050	L7□B075	L7□B020	L7□B035	L7□B050	L7□B075	L7□B150		
Flange Size(□)	□ 130				□ 180				□ 220					
Rated Output [kW]	0.6	1.1	1.6	2.2	2.2	3.5	5.5	7.5	2.2	3.5	5.5	7.5	11	
Rated Torque	[N · m]	2.86	5.25	7.64	10.5	10.5	16.71	26.26	35.81	10.50	16.71	26.26	35.81	52.52
	[kgf · cm]	29.23	53.59	77.95	107.19	107.19	170.52	267.96	365.41	107.19	170.52	267.96	365.41	535.93
Max. Instantaneous	[N · m]	8.59	15.76	22.92	31.51	31.51	50.13	65.65	89.52	31.51	50.13	78.78	89.52	131.30
	[kgf · cm]	87.7	160.78	233.86	321.56	321.56	511.57	669.91	913.52	321.56	511.57	803.89	913.52	1339.82
Rated Current [A]	1.78	3.27	4.79	6.54	6.56	10.07	15.82	21.36	6.27	10.03	15.66	18.42	27.41	
Max. Current [A]	5.18	9.5	13.92	19	19.17	29.43	38.64	52.16	18.43	29.51	46.08	45.25	67.33	
Rated Speed [r/min]	2000													
Max. Speed [r/min]	3000											2500		
Inertia	[kg · m ² × 10 ⁻⁴]	6.659	11.999	17.339	22.679	30.74	52.13	83.6	121.35	51.42	80.35	132.41	172.91	291.36
	[gf · cm · s ²]	6.795	12.244	17.693	23.142	31.367	53.194	85.306	123.827	52.47	81.99	135.11	176.44	297.10
Allowable Load Inertia Ratio	10 times of motor inertia					5 times of motor inertia								
Rated Power Rate [kW/s]	12.32	22.99	48.64	91.96	35.89	53.57	82.49	105.67	21.46	34.76	52.08	74.16	94.65	
Speed/Position Detector	Standard Note1	Quad. Type Incremental 3000[P/R]												
	Option	Serial Type 19[Bit]												
Specifications & Features	Structure	Fully closed · Self cooling IP65 Note1												
	Rated Time	Continuous												
	Ambient Temp	Operating : 0 ~ 40[°C] Storage : -10 ~ 60[°C]												
	Ambient Humidity	90[%]RH Below (avoid dew-condensation)												
	Atmosphere	Avoid direct sunlight, no corrosive gas, inflammable gas, oil mist, or dust.												
	E/V	Elevation/vibration 49[m/s ²](5G)												
Weight [kg]	5.5	7.54	9.68	11.78	12.4	17.7	26.3	35.6	16.95	21.95	30.8	37.52	66.2	

Note1) Except for axis penetration, when you attach reducer to the motor, we don't guarantee IP for reducer. If you bend over specification designated in cable standard, it is difficult to guarantee IP marked. It can be satisfied protection grade when you use private cable only.

Speed-Torque Characteristics

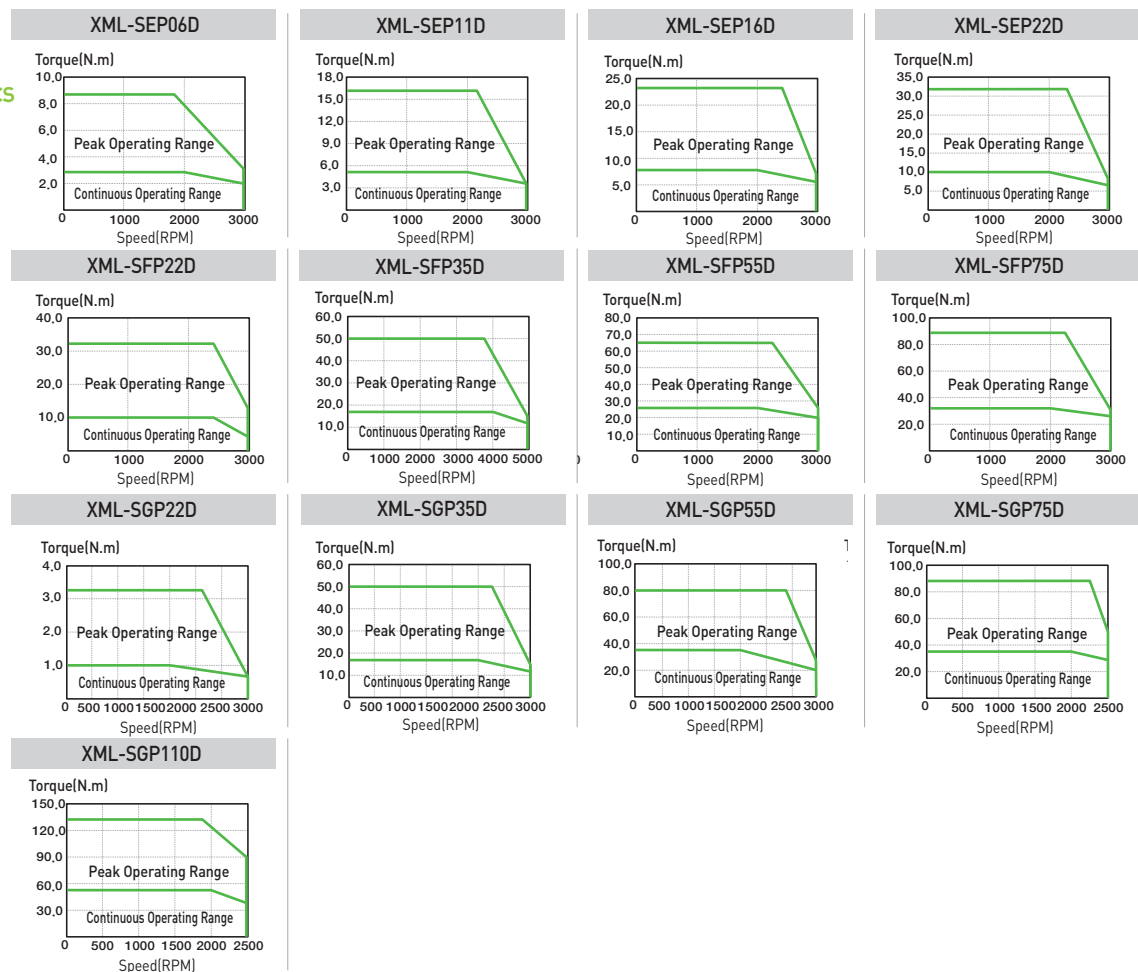

Motor Specifications [Rated 1500r/min]

Servo Motor (XML-□□□□)	SEP05G	SEP09G	SEP13G	SEP17G	SEP20G	SFP30G	SFP44G	SFP60G	SFP75G	SGP20G	SGP30G	SGP44G	SGP60G	SGP85G	SGP110G	SGP150G	
Applicable Drive (L7□A□□)	L7□B010		L7□B020		L7□B020	L7□B050		L7□B075	L7□B150	L7□B020	L7□B050		L7□B075	L7□B150			
Flange Size(□)	□130				□180					□220							
Rated Output [kW]	0.45	0.85	1.3	1.7	1.8	2.9	4.4	6	7.5	1.8	2.9	4.4	6	8.5	11	15	
Rated Torque	[N · m]	2.86	5.41	8.28	10.82	11.46	18.46	28.01	38.2	47.75	11.46	18.46	28.01	38.2	54.11	70.03	95.49
	[kgf · cm]	29.23	55.22	84.45	110.43	116.43	188.39	285.83	389.77	487.21	116.93	188.39	285.83	389.77	552.17	714.57	974.42
Max. Instantaneous	[N · m]	8.59	16.23	24.83	32.47	34.38	55.39	70.03	95.49	119.37	34.38	55.39	70.03	95.49	135.28	175.07	219.6
	[kgf · cm]	87.7	165.65	253.35	331.3	350.79	565.16	714.57	974.42	1218.02	350.79	565.16	714.57	974.42	1380.43	1786.43	2240
Rated Current [A]	1.78	3.37	5.19	6.74	7.15	11.12	16.87	22.78	28.13	6.84	11.08	16.71	19.65	28.24	28.28	35.71	
Max. Current [A]	5.18	9.79	15.07	19.58	20.91	165.9	41.21	55.64	65.7	20.11	33	49.15	48.23	69.37	68.83	87.7	
Rated Speed [r/min]	1500																
Max. Speed [r/min]					3000					2500		3000		2500		2000	
Inertia	[kg · m ² × 10 ⁻⁴]	6.659	11.999	17.339	22.679	30.74	52.13	83.6	121.35	143.82	51.42	80.35	132.41	172.91	291.36	291.36	385.54
	[gf · cm · s ²]	6.795	12.244	17.693	23.142	31.367	53.194	85.306	123.827	146.755	52.47	81.99	135.11	176.44	297.31	297.1	393.14
Allowable Load Inertia Ratio	10 times of motor inertia								5 times of motor inertia								
Rated Power Rate [kW/s]	12.32	24.4	57.08	97.61	42.72	65.38	93.86	120.23	158.51	25.531	42.41	59.25	84.36	100.5	168.3	214.8	
Speed/Position Detector	Standard Note1	Quad. Type Incremental 3000[P/R]															
	Option	Serial Type 19[Bit]															
Specifications & Features	Structure	Fully closed · Self cooling IP65 Note1															
	Rated Time	Continuous															
	Ambient Temp	Operating : 0 ~ 40[°C] Storage : -10 ~ 60[°C]															
	Ambient Humidity	90[%]RH Below (avoid dew-condensation)															
	Atmosphere	Avoid direct sunlight, no corrosive gas, inflammable gas, oil mist, or dust.															
	E/V	Elevation/vibration 49[m/s ²][5G]															
Weight [kg]	5.5	7.54	9.68	11.78	12.4	17.7	26.3	35.6	39.4	16.95	21.95	30.8	37.52	66.2	66.3	92.2	

Note1) Except for axis penetration, when you attach reducer to the motor, we don't guarantee IP for reducer. If you bend over specification designated in cable standard, it is difficult to guarantee IP marked. It can be satisfied protection grade when you use private cable only.

Servo Motor

Speed-Torque Characteristics

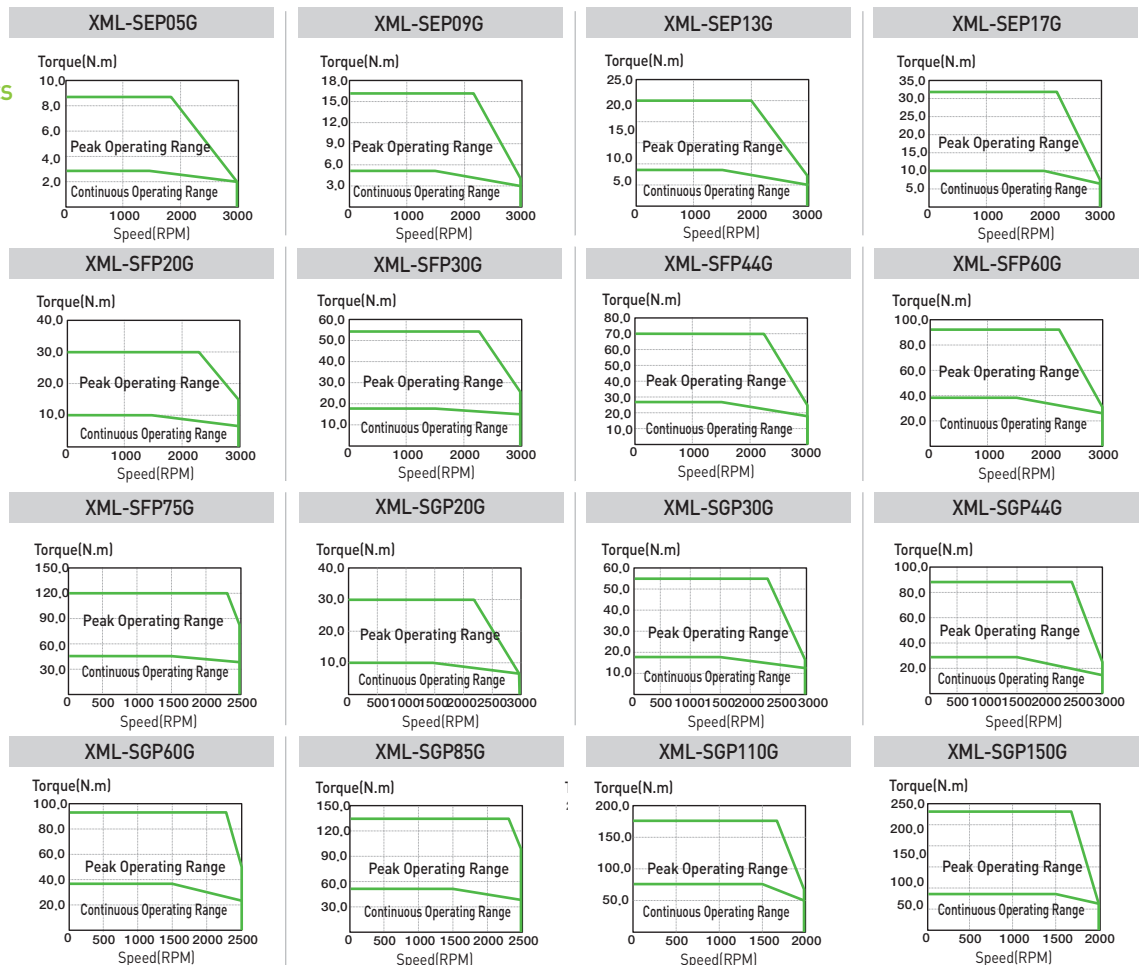

Motor Specifications [Rated 1000r/min]

Servo Motor [XML-□□□□]	SEP03M	SEP06M	SEP09M	SEP12M	SFP12M	SFP20M	SFP30M	SFP44M	SGP12M	SGP20M	SGP30M	SGP44M	SGP60M	
Applicable Drive [L7□A□□]	L7□B010		L7□B035		L7□B020		L7□B050		L7□B020		L7□B050		L7□B150	
Flange Size[□]	□ 130				□ 180				□ 220					
Rated Output [kW]	0.3	0.6	0.9	1.2	1.2	2	3	4.4	1.2	2	3	4.4	6	
Rated Torque	[N · m]	2.86	5.73	8.59	11.46	11.46	19.1	28.65	42.02	11.46	19.1	28.65	42.02	57.3
	[kgf · cm]	29.23	58.47	87.7	116.93	116.93	194.88	292.33	428.74	116.93	194.88	292.33	428.74	584.65
Max. Instantaneous	[N · m]	8.59	17.19	25.78	34.38	34.38	57.3	71.62	105.04	34.38	57.3	85.94	105.04	143.24
	[kgf · cm]	87.7	175.4	263.09	350.79	350.79	584.65	730.81	1,074.86	350.79	584.65	876.98	1,071.86	1,461.63
Rated Current [A]	1.26	2.42	3.62	4.8	4.77	7.88	11.92	17.15	4.72	7.84	11.73	17.29	23.58	
Max. Current [A]	3.65	7.04	10.51	13.95	13.94	23.03	29.12	41.88	13.87	23.06	34.51	50.87	57.92	
Rated Speed [r/min]	1000													
Max. Speed [r/min]	2000													
Inertia	[kg · m ² × 10 ⁻⁴]	6.659	11.999	17.339	22.679	30.71	52.13	83.6	121.35	51.42	80.35	132.41	172.91	291.36
	[gf · cm · s ²]	6.795	12.444	17.693	23.142	31.367	53.194	85.306	123.827	52.47	81.99	135.11	176.44	297.31
Allowable Load Inertia Ratio	10 times of motor inertia						5 times of motor inertia							
Rated Power Rate [kW/s]	12.32	27.36	42.6	57.9	42.72	69.97	98.17	145.48	25.53	45.39	61.97	102.08	112.64	
Speed/Position Detector	Standard Note1	Quad. Type Incremental 3000[P/R]												
	Option	Serial Type 19[Bit]												
Specifications & Features	Structure	Fully closed · Self cooling IP65 Note1												
	Rated Time	Continuous												
	Ambient Temp	Operating : 0 ~ 40[°C] Storage : -10 ~ 60[°C]												
	Ambient Humidity	90[%]RH Below [avoid dew-condensation]												
	Atmosphere	Avoid direct sunlight, no corrosive gas, inflammable gas, oil mist, or dust.												
	E/V	Elevation/vibration 49[m/s ²][5G]												
Weight [kg]	5.5	7.54	9.68	11.78	12.4	17.7	26.3	35.6	16.95	21.95	30.8	37.52	66.2	

Note1) Except for axis penetration, when you attach reducer to the motor, we don't guarantee IP for reducer. If you bend over specification designated in cable standard, it is difficult to guarantee IP marked. It can be satisfied protection grade when you use private cable only.

Speed-Torque Characteristics

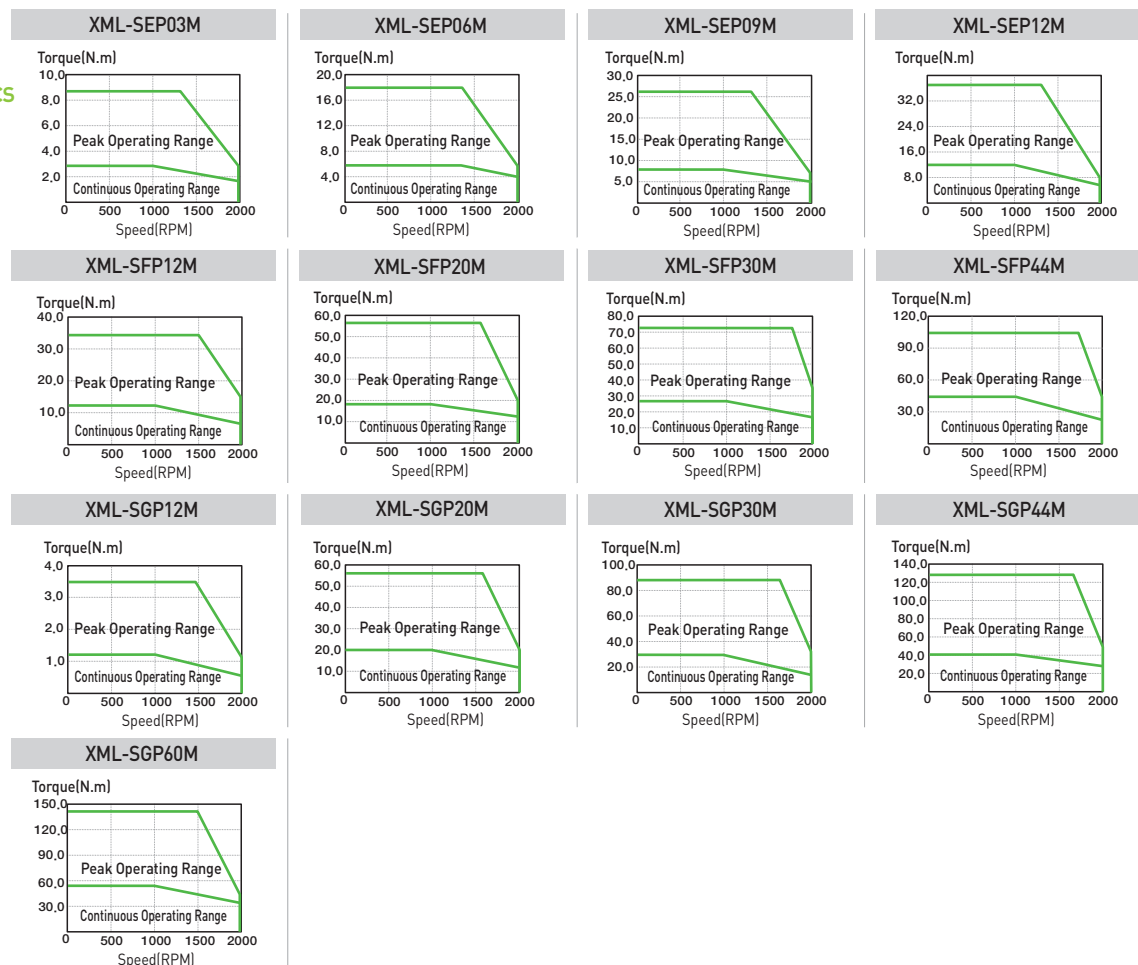

SA Series

Plug Specifications



Spec.: 172167-1
(Made by AMP)

Power

Pin No.	Color	Signal
1	Red	U
2	White	V
3	Black	W
4	Green	Ground

(Power Connector Pin Table)



Spec.: 172165-1
(Made by AMP)

Brake

Pin No.	Signal
1	BK+
2	BK-

(Brake Connector Pin Table)

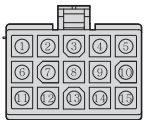

Spec.: 172165-1
(Made by AMP)

Encoder

Pin No.	Signal	Pin No.	Signal
1	A	9	V
2	A	10	V
3	B	11	W
4	B	12	W
5	Z	13	+5V
6	Z	14	0V
7	U	15	SHIELD
8	U		

(Parallel Encoder Connector Pin Table)

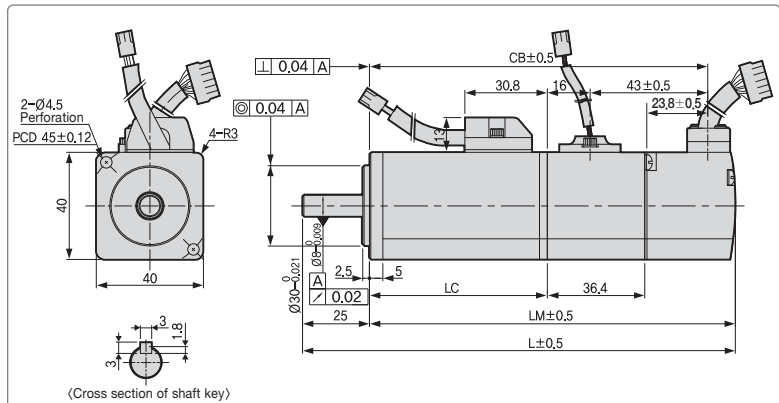

Model	External Dimensions(mm)				Weight(kg)
	L	LM	LC	CB	
SAR3A	101.3(137.6)	76.3(112.6)	42.5(42.4)	66.3(102.3)	0.32(0.67)
SAR5A	108.3(144.6)	83.3(119.6)	49.5(49.4)	73.3(109.3)	0.38(0.73)
SA01A	125.3(161.6)	100.3(136.6)	66.5(66.4)	90.3(126.6)	0.5(0.85)
SA015A	145.3	120.3	86.5	110.3	0.7

Note1) Use DC[24V] for brake input power supply. Note2) The () is for brake-attached type. Note3) For external dimensions for oil-sealed type. Please kindly contact us separately.
Note4) Refer to page 74 for serial encoder pin table.

SB Series

Plug Specifications



Spec.: 172167-1
(Made by AMP)

Power

Pin No.	Color	Signal
1	Red	U
2	White	V
3	Black	W
4	Green	Ground

(Power Connector Pin Table)



Spec.: 172165-1
(Made by AMP)

Brake

Pin No.	Signal
1	BK+
2	BK-

(Brake Connector Pin Table)

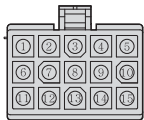

Spec.: 172171-1
(Made by AMP)

Encoder

Pin No.	Signal	Pin No.	Signal
1	A	9	V
2	A	10	V
3	B	11	W
4	B	12	W
5	Z	13	+5V
6	Z	14	0V
7	U	15	SHIELD
8	U		

(Parallel Encoder Connector Pin Table)

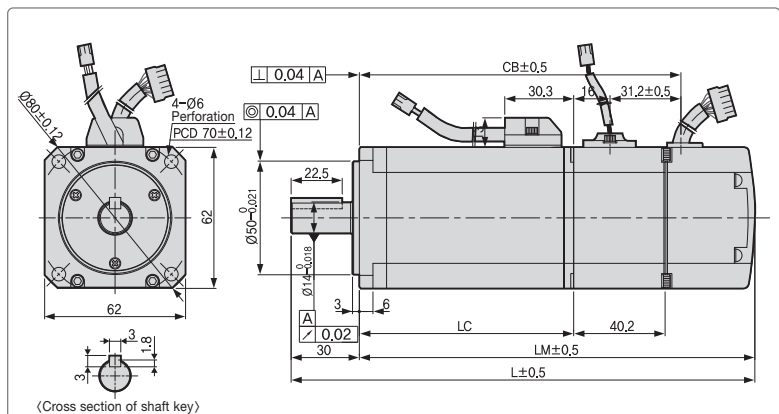

Model	External Dimensions(mm)				Weight(kg)
	L	LM	LC	CB	
SB01A	122(162)	92(132)	52.5(52.3)	59.5(99.5)	0.82(1.4)
SB02A	136(176)	106(146)	66.5(66.3)	73.5(113.5)	1.08(1.66)
SB04A	164(204)	134(174)	94.5(94.3)	101.5(141.5)	1.58(2.16)

Note1) Use DC[24V] for brake input power supply. Note2) The () is for brake-attached type. Note3) For external dimensions for oil-sealed type. Please kindly contact us separately.
Note4) Refer to page 74 for serial encoder pin table.

SC Series

Plug Specifications



Spec.: 172167-1
(Made by AMP)

Power

Pin No.	Color	Signal
1	Red	U
2	White	V
3	Black	W
4	Green	Ground

(Power Connector Pin Table)



Spec.: 172165-1
(Made by AMP)

Brake

Pin No.	Signal
1	BK+
2	BK-

(Brake Connector Pin Table)

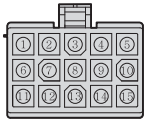

Spec.: 172171-1
(Made by AMP)

Encoder

Pin No.	Signal	Pin No.	Signal
1	A	9	V
2	Ā	10	V̄
3	B	11	W
4	B̄	12	W̄
5	Z	13	+5V
6	Z̄	14	0V
7	U	15	SHIELD
8	Ū		

(Parallel Encoder Connector Pin Table)

- Note1)** Use DC[24V] for brake input power supply. **Note2)** The [] is for brake-attached type. **Note3)** For external dimensions for oil-sealed type. Please kindly contact us separately. **Note4)** Refer to page 74 for serial encoder pin table.

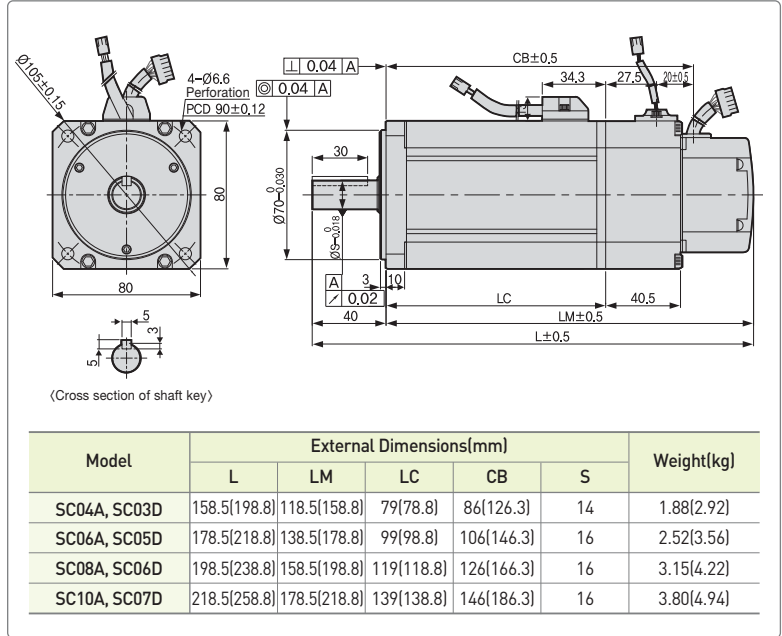

SE, SEP Series

Plug Specifications

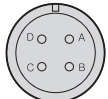

Spec.: MS3102A20-4P
(Standard)

Power

Pin No.	Signal
A	U
B	V
C	W
D	Ground

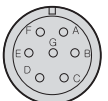

Spec.: MS3102A20-15P
(Brake-attached type)

Brake

Pin No.	Signal	Pin No.	Signal
A	U	D	Ground
B	V	E	BK+
C	W	F	BK-

1. Incremental type



Spec.: MS3102A20-29P

Encoder

Pin No.	Signal	Pin No.	Signal
A	A	M	V
B	Ā	N	V̄
C	B	P	W
D	B̄	R	W̄
E	Z	H	+5V
F	Z̄	G	0V
K	U	J	SHIELD
L	Ū		

(Parallel Encoder Connector Pin Table)

- Note1)** Use DC[24V] for brake input power supply. **Note2)** The [] is for brake-attached type. **Note3)** For external dimensions for oil-sealed type. Please kindly contact us separately. **Note4)** Refer to page 74 for serial encoder pin table.

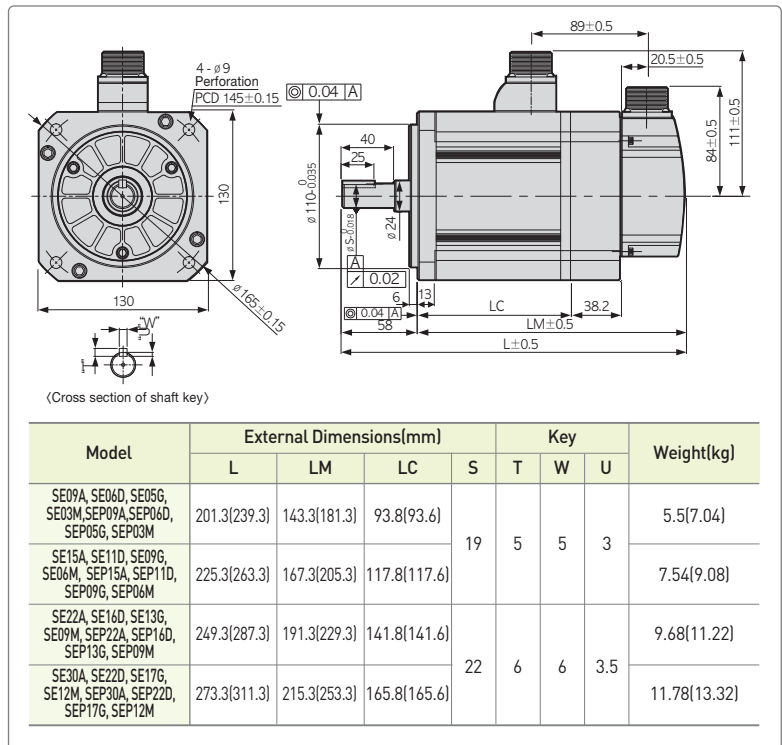

SF, LF, SFP Series

Plug Specifications

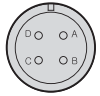

Spec.: MS3102A22-22P
(Standard)

Power

Pin No.	Signal
A	U
B	V
C	W
D	Ground

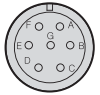

Spec.: MS3102A24-10P
(Brake-attached type)

Pin No.	Signal	Pin No.	Signal
A	U	D	Ground
B	V	E	BK+
C	W	F	BK-

1. Incremental type



Spec.: MS3102A20-29P

Encoder

Pin No.	Signal	Pin No.	Signal
A	A	M	V
B	A	N	V
C	B	P	W
D	B	R	W
E	Z	H	+5V
F	Z	G	0V
K	U	J	SHIELD
L	U		

(Parallel Encoder Connector Pin Table)

- Note1) Use DC[24V] for brake input power supply.
- Note2) The () is for brake-attached type.
- Note3) For external dimensions for oil-sealed type. Please kindly contact us separately.
- Note4) Refer to page 74 for serial encoder pin table.
- Note5) Use MS3102A32-17 for SF75G Power connector

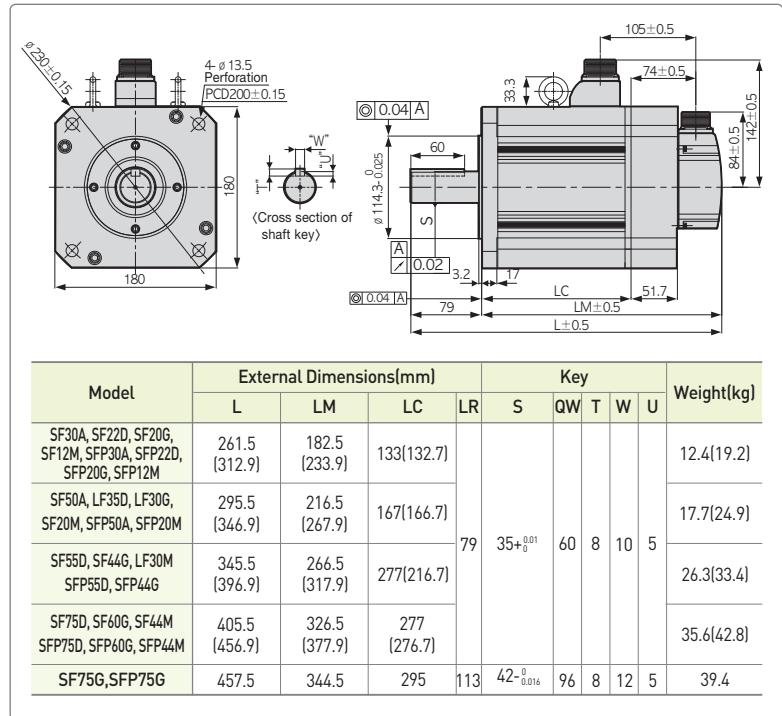

SG, LG, SGP Series

Plug Specifications

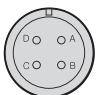

Spec.: MS3102A22-22P
(Standard)

Power

Pin No.	Signal
A	U
B	V
C	W
D	Ground

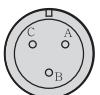

Spec.: MS3102A14S-7P
(Brake-attached type)

Brake

Pin No.	Signal
A	BK+
B	BK-
C	NC

1. Incremental type

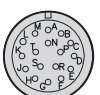

Spec.: MS3102A20-29P

Encoder

Pin No.	Signal	Pin No.	Signal
A	A	M	V
B	A	N	V
C	B	P	W
D	B	R	W
E	Z	H	+5V
F	Z	G	0V
K	U	J	SHIELD
L	U		

(Parallel Encoder Connector Pin Table)

- Note1) In case of SG, use DC[90V] for brake input power supply.
- Note2) The () is for brake-attached type.
- Note3) For external dimensions for oil-sealed type. Please kindly contact us separately.
- Note4) Refer to page 74 for serial encoder pin table.
- Note5) Use MS3102A32-17 for SG60M Power connector.

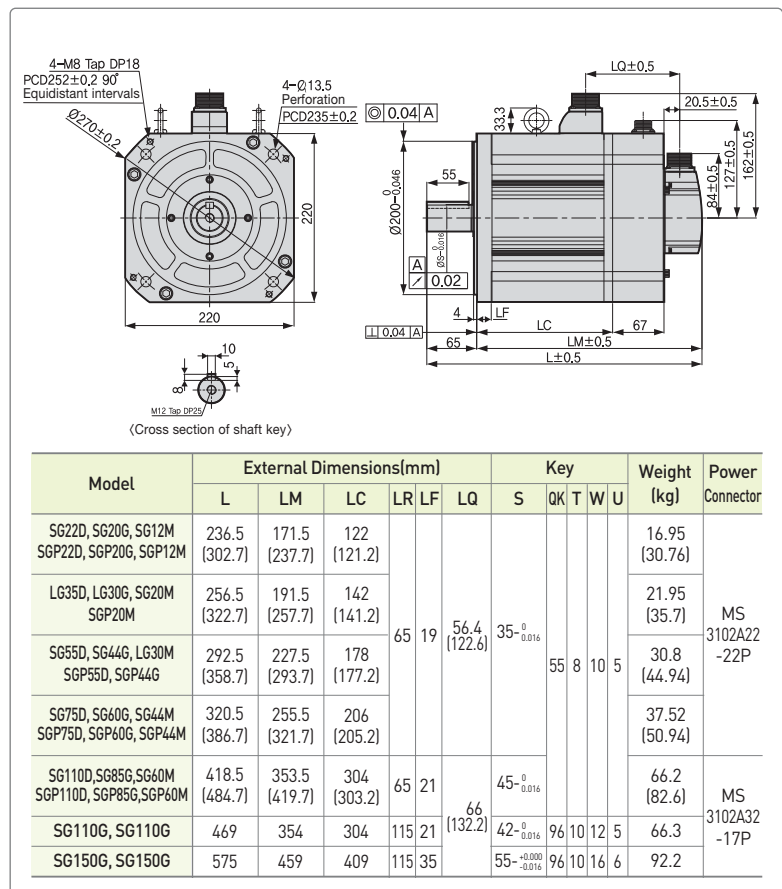

HB Series [Hollow Shaft type]

Plug Specifications



Spec.: 172167-1
(Made by AMP)

Power

Pin No.	Color	Signal
1	Red	U
2	White	V
3	Black	W
4	Green	Ground

(Power Connector Pin Table)

1. Incremental type

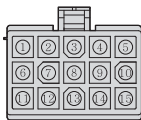

Spec.: 172171-1
(Made by AMP)

Encoder

Pin No.	Signal	Pin No.	Signal
1	A	9	V
2	A	10	V
3	B	11	W
4	B	12	W
5	Z	13	+5V
6	Z	14	0V
7	U	15	SHIELD
8	U		

(Parallel Encoder Connector Pin Table)

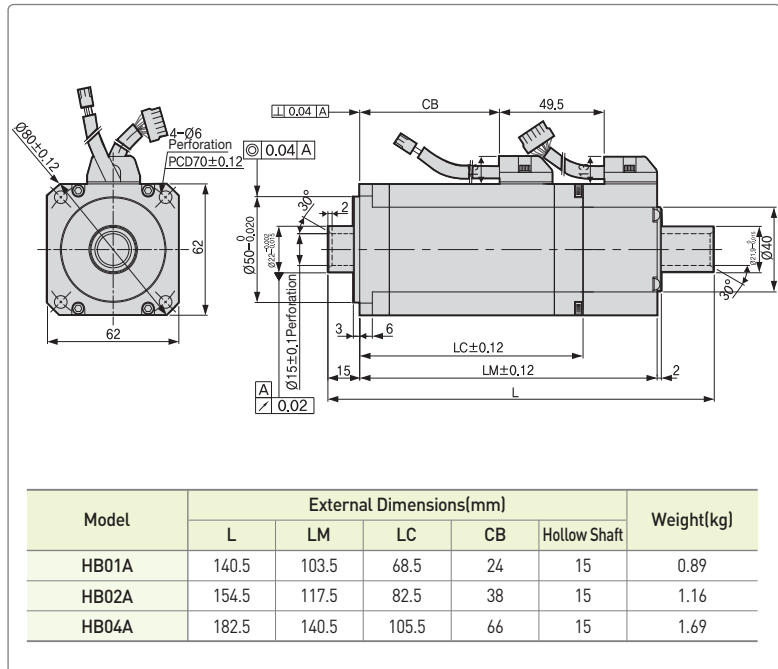

HE Series [Hollow Shaft type]

Plug Specifications



Spec.: MS3102A20-4P
(Standard)

Power

Pin No.	Signal
A	U
B	V
C	W
D	Ground

(Power Connector Pin Table)



Spec.: MS3102A20-29P

Encoder

Pin No.	Signal	Pin No.	Signal
A	A	M	V
B	A	N	V
C	B	P	W
D	B	R	W
E	Z	H	+5V
F	Z	G	0V
K	U	J	SHIELD
L	U		

(Parallel Encoder Connector Pin Table)

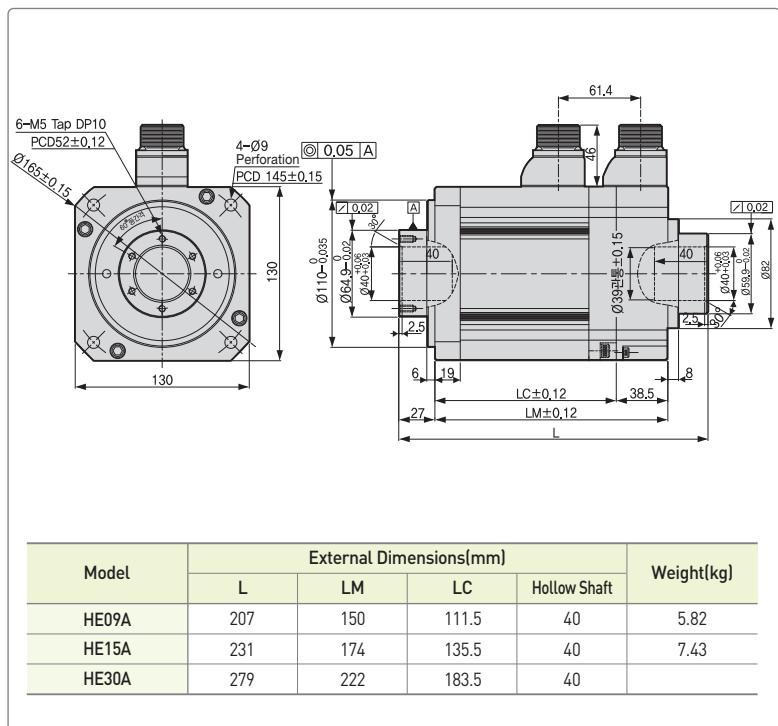

Electric Brake Specifications

Applicable Motor Series	XML-SA,FAL	XML-SB,FB,FBL	XML-SC,FC,FCL	XML-SE,SEP,FE,FEP	XML-SE,SEP,FF,FFP	XML-SG,SGP,FG,FGP
Purpose	Maintenance					
Input voltage [V]	DC 24V	DC 24V	DC 24V	DC 24V	DC 24V	DC 90V
Static friction torque [N · m]	0.32	1.47	3.23	10.4	40	74
Capacity [W]	6	6.5	9	19.4	25	32
Coil resistance [Ω]	96	89	64	29.6	23	327
Rated current [A]	0.25	0.27	0.38	0.81	1.04	0.28
Braking mechanism	Spring brake					
Insulation grade	GraDde F					

- Note1) For the Electronic Brake that is attached to our Servo Motor, the same specifications are to be applied as per the series.
- Note2) Do not use it for braking purpose because the electronic brake is only for maintaining the stopped condition.
- Note3) The characteristics of electronic brake is measured at 20°C
- Note4) Please make sure to always check the voltage specification on the motor because indicated brake specifications are subject to change.

S Series Encoder Pin Map

SA, SB, SC Series

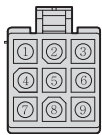

Plug Specification:
172169-1(AMP)

Single Turn (N)		Multi Turn (M)	
핀번호	신호명	핀번호	신호명
1	MA	1	MA
2	MA	2	MA
3	SLO	3	SLO
4	SLO	4	SLO
5	-	5	VDD_B
6	-	6	GND_B
7	+5V	7	+5V
8	OV	8	OV
9	SHIELD	9	SHIELD

(Serial Encoder Connector Pin Table)

SE, SF, SG Series



17 Pole Plug
(MS3102A20-29P)

Single Turn (N)				Multi Turn (M)			
Pin No.	Signal	Pin No.	Signal	Pin No.	신호명	Pin No.	Signal
A	MA	M	-	A	MA	M	-
B	MA	N	-	B	MA	N	-
C	SLO	P	-	C	SLO	P	-
D	SLO	R	-	D	SLO	R	-
E	-	H	+5V	E	VDD_B	H	+5V
F	-	G	OV	F	GND_B	G	OV
K	-	J	MA	K	-	J	MA
L	-	-	-	L	-	-	-

(Serial Encoder Connector Pin Table)

Heat Sink Specifications

Flange	Dimensions(mm)	Materials
AP04	250 X 250 X 6	Aluminum
AP06	250 X 250 X 6	
AP08	250 X 250 X 12	
AP13	350 X 350 X 20	
AP18	550 X 550 X 30	
AP22	650 X 650 X 35	

- Note1) The data on the product features is measured when those heat sinks are applied.

Servo Motor Designation

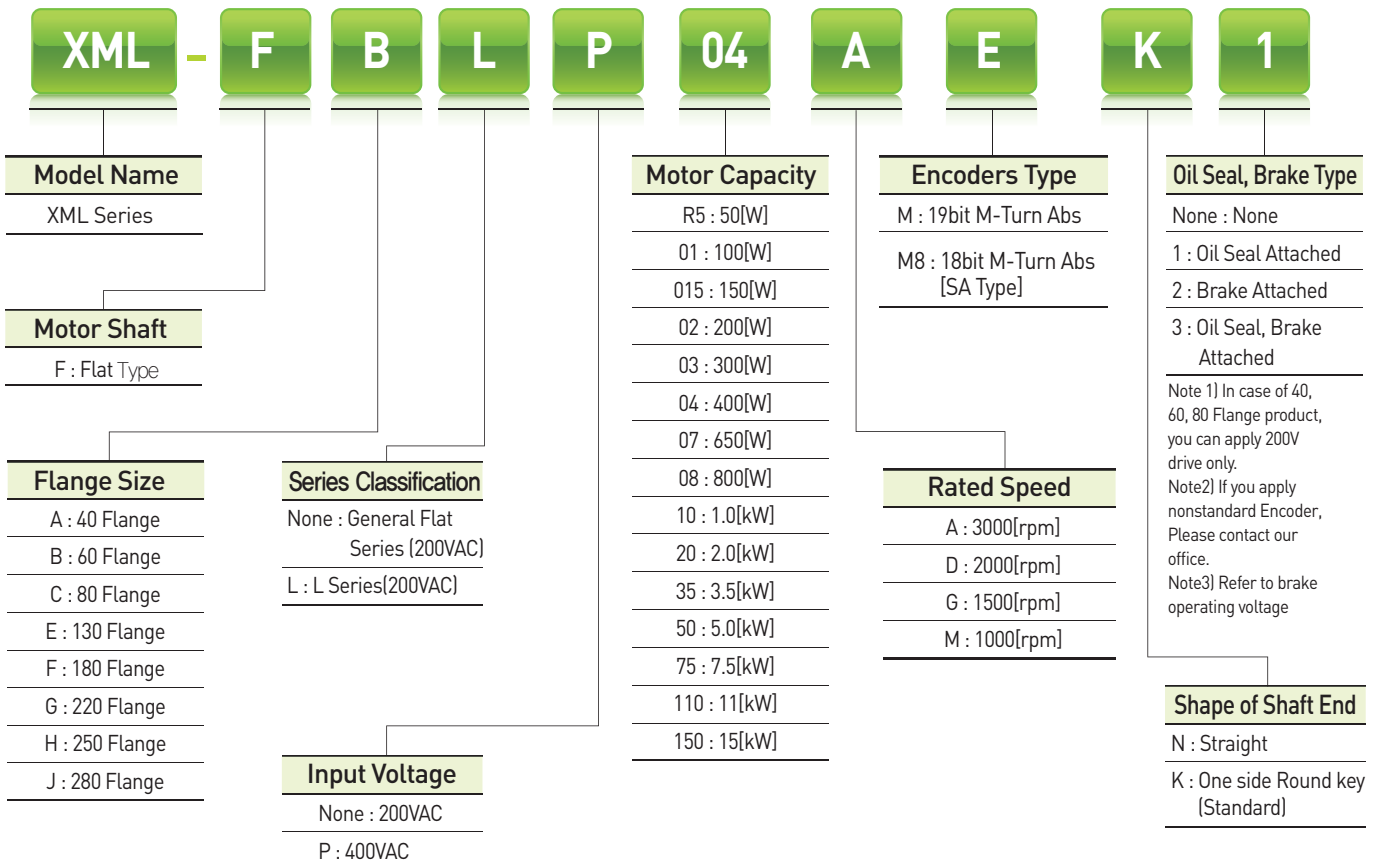

Servo Motor Characteristics

Motor Specifications [Rated 3000r/min, 2000r/min]

Servo Motor (XML-□□□□)	FALR5A	FAL01A	FAL015A	FBL01A	FBL02A	FBL04A	FCL04A	FCL06A	FCL08A	FCL10A	FCL03D	FCL05D	FCL06D	FCL07D
Applicable Drive	L7□A001	L7□A002	L7□A001	L7□A002	L7□A004	L7□A004	L7□A008	L7□A010	L7□A004	L7□A008				
Flange Size(□)	□40				□60				□80					
Rated Output [kW]	0.05	0.1	0.15	0.1	0.2	0.4	0.4	0.6	0.75	1	0.3	0.45	0.55	0.65
Rated Torque [N·m]	0.16	0.32	0.48	0.32	0.64	1.27	1.27	1.91	2.39	3.18	1.43	2.15	2.63	3.1
[kgf·cm]	1.62	3.25	4.87	3.25	6.49	12.99	12.99	19.49	24.36	32.48	14.62	21.92	26.8	31.67
Max. Instantaneous [N·m]	0.48	0.96	1.43	0.96	1.91	3.82	3.82	5.73	7.16	9.55	4.3	6.45	7.88	9.31
[kgf·cm]	4.87	9.74	14.62	9.74	19.48	38.96	38.98	58.47	73.08	97.44	43.85	65.77	80.39	95.01
Rated Current [A]	0.95	1.25	1.76	0.95	1.45	2.6	2.58	3.81	5.02	5.83	2.5	3.05	3.06	3.83
Max. Current [A]	2.85	3.75	5.28	2.85	4.35	7.8	7.75	11.42	15.07	17.5	7.51	9.16	9.18	11.5
Rated Speed [r/min]	3000										2000			
Max. Speed [r/min]	5000										3000			
Inertia [kg·m ² ×10 ⁻⁴]	0.023	0.042	0.063	0.091	0.147	0.248	0.53	0.897	1.264	1.632	0.53	0.897	1.264	1.63
[gf·cm·s ²]	0.024	0.043	0.065	0.093	0.15	0.253	0.541	0.915	1.29	1.665	0.541	0.915	1.29	1.66
Allowable Load Inertia Ratio	30 times of motor inertia				20 times of motor inertia				15 times of motor inertia					
Rated Power Rate [kW/s]	10.55	23.78	35.34	11.09	27.6	27.07	30.6	40.66	45.09	62.08	38.73	51.47	54.56	59.03
Speed/Position Detector	Standard Note1	Serial Multi-Turn Built-in Type(18bit)				Serial Multi-Turn Built-in Type(19bit)								
	Option	×												
Specifications & Features	Structure	Fully closed · Self cooling IP65 Note1												
	Rated Time	Continuous												
	Ambient Temp	Operating : 0 ~ 40[°C] Storage : -10 ~ 60[°C]												
	Ambient Humidity	90[%]RH Below [avoid dew-condensation]												
	Atmosphere	Avoid direct sunlight, no corrosive gas, inflammable gas, oil mist, or dust.												
	E/V	Elevation/vibration 49[m/s ²][5G]												
Weight [kg]	0.31	0.45	0.61	0.56	0.74	1.06	1.52	2.14	2.68	3.3	1.26	2.12	2.66	2.78

Note1) Except for axis penetration, when you attach reducer to the motor, we don't guarantee IP for reducer. If you bend over specification designated in cable standard, it is difficult to guarantee IP marked. It can be satisfied protection grade when you use private cable only.

Servo Motor

Speed-Torque Characteristics

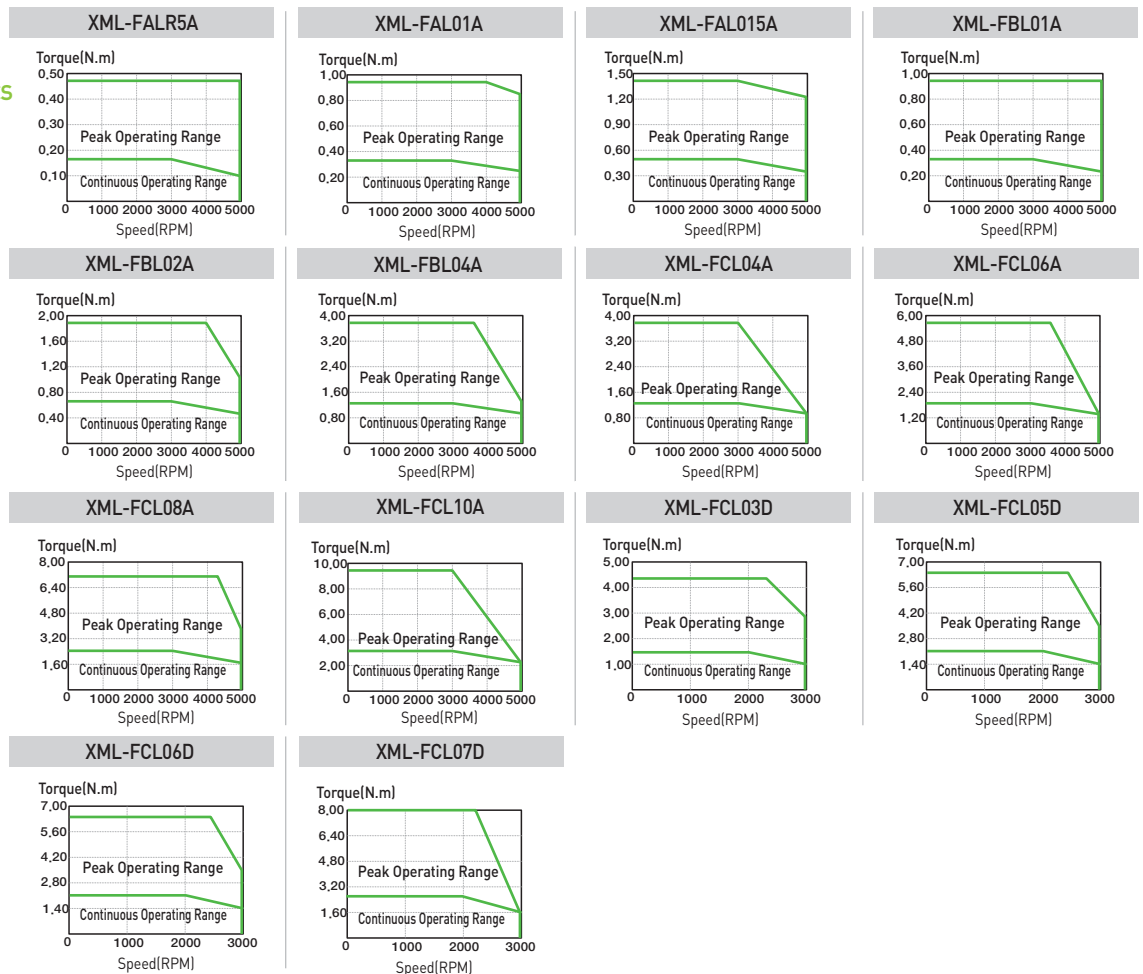

Motor Specifications [Rated 3000r/min]

Servo Motor (XML-□□□□)	FB01A	FB02A	FB04A	FC04A	FC06A	FC08A	FC10A	FE09A	FE15A	FE22A	FE30A	FF30A	FF50A
Applicable Drive	L7□A001	L7□A002	L7□A004	L7□A004	L7□A008			L7□A010	L7□A020		L7□A035	L7□A035	L7□A050
Flange Size(□)	□60			□80					□130			□180	
Rated Output [kW]	0.1	0.2	0.4	0.4	0.6	0.75	1	0.9	1.5	2.2	3	3	5
Rated Torque [N·m]	0.32	0.64	1.27	1.27	1.91	2.39	3.18	2.86	4.77	7	9.55	9.55	15.91
[kgf·cm]	3.25	6.5	12.99	13	19.5	24.36	32.5	29.2	48.7	71.4	97.4	97.4	162.3
Max. Instantaneous [N·m]	0.96	1.91	3.82	3.82	5.73	7.16	9.55	8.59	14.32	21.01	28.65	28.65	47.74
[kgf·cm]	9.74	19.49	38.98	38.98	58.47	73.08	97.44	87.7	146.1	214.3	292.2	292.3	487
Rated Current [A]	0.95	1.45	2.6	2.58	3.81	5.02	6.7	6.45	9.15	13.24	16.09	15.26	26.47
Max. Current [A]	2.86	4.35	7.79	7.75	11.42	15.07	20.09	19.35	27.45	39.72	48.27	45.78	79.41
Rated Speed [r/min]	3000												
Max. Speed [r/min]	5000												
Inertia [kg·m ² ×10 ⁻⁴]	0.09	0.15	0.25	0.5	0.88	1.25	1.62	5.66	10.18	14.62	19.04	27.96	46.56
[gf·cm·s ²]	0.09	0.15	0.25	0.51	0.89	1.27	1.65	5.77	10.39	14.92	19.43	28.53	47.51
Allowable Load Inertia Ratio	20 times of motor inertia			15 times of motor inertia			10 times of motor inertia					5 times of motor inertia	
Rated Power Rate [kW/s]	11.38	27.95	65.9	32.62	41.69	45.78	62.74	14.47	22.38	33.59	47.85	32.59	54.33
Speed/Position Detector	Standard Note1	Serial Type 19[Bit]											
	Option	×											
Specifications & Features	Structure	Fully closed · Self cooling IP65 Note1											
	Rated Time	Continuous											
	Ambient Temp	Operating : 0 ~ 40[°C] Storage : -10 ~ 60[°C]											
	Ambient Humidity	90[%]RH Below [avoid dew-condensation]											
	Atmosphere	Avoid direct sunlight, no corrosive gas, inflammable gas, oil mist, or dust.											
	E/V	Elevation/vibration 49[m/s ²][5G]											
Weight [kg]	0.7	0.9	1.3	1.6	2.2	2.7	3.8	5	6.7	8.5	10.1	12.5	17.4

Note1) Except for axis penetration, when you attach reducer to the motor, we don't guarantee IP for reducer. If you bend over specification designated in cable standard, it is difficult to guarantee IP marked. It can be satisfied protection grade when you use private cable only.

Speed-Torque Characteristics

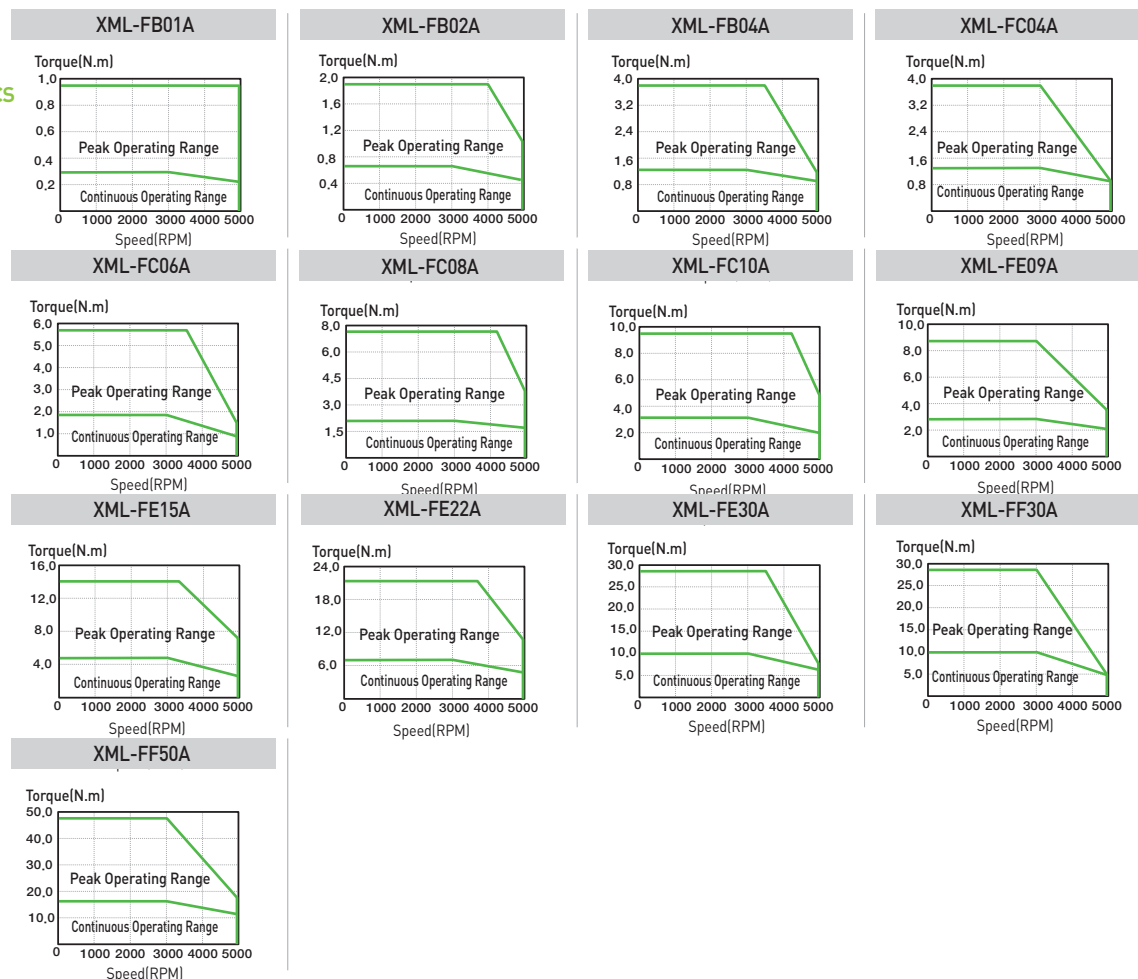

Motor Specifications [Rated 2000r/min]

Servo Motor (XML-□□□□)		FC03D	FC05D	FC06D	FC07D	FE06D	FE11D	FE16D	FE22D
Applicable Drive		L7□A004	L7□A008			L7□A010		L7□A020	
Flange Size(□)		□80				□130			
Rated Output	[kW]	0.3	0.45	0.55	0.65	0.6	1.1	1.6	2.2
	[N · m]	1.43	2.15	2.6	3.1	2.86	5.25	7.63	10.5
Rated Torque	[kgf · cm]	14.6	21.9	26.8	31.7	29.20	53.6	77.9	107.1
	[N · m]	4.3	6.45	7.88	9.31	8.59	15.75	22.92	31.51
Max. Instantaneous	[kgf · cm]	43.8	65.8	80.4	95	87.7	160.7	233.8	321.4
	[A]	2.5	3.05	3.06	3.83	4.56	6.47	10.98	12.97
Rated Current	[A]	7.51	9.16	9.18	11.5	13.68	19.41	32.94	38.91
Rated Speed	[r/min]	2000							
Max. Speed	[r/min]	3000							
Inertia	[kg · m ² X10 ⁻⁴]	0.5	0.88	1.25	1.62	5.66	10.18	14.62	19.04
	[gf · cm · s ²]	0.51	0.89	1.27	1.65	5.77	10.39	14.92	19.43
Allowable Load Inertia Ratio		15 times of motor inertia				10 times of motor inertia			
Rated Power Rate	[kW/s]	41.28	52.76	55.39	59.64	14.49	27.08	39.89	57.9
Speed/Position Detector	Standard Note1	Serial Multi-Turn Built-in Type(19bit)							
	Option	×							
Specifications & Features	Structure	Fully closed · Self cooling IP65 Note1							
	Rated Time	Continuous							
	Ambient Temp	Operating : 0 ~ 40[°C] Storage : -10 ~ 60[°C]							
	Ambient Humidity	90[%]RH Below (avoid dew-condensation)							
	Atmosphere	Avoid direct sunlight, no corrosive gas, inflammable gas, oil mist, or dust.							
Weight	E/V	Elevation/vibration 49[m/s2][5G]							
	[kg]	1.6	2.2	2.7	3.8	5	6.7	8.5	10.1

Note1) Except for axis penetration, when you attach reducer to the motor, we don't guarantee IP for reducer. If you bend over specification designated in cable standard, it is difficult to guarantee IP marked It can be satisfied protection grade when you use private cable only.

Speed-Torque Characteristics

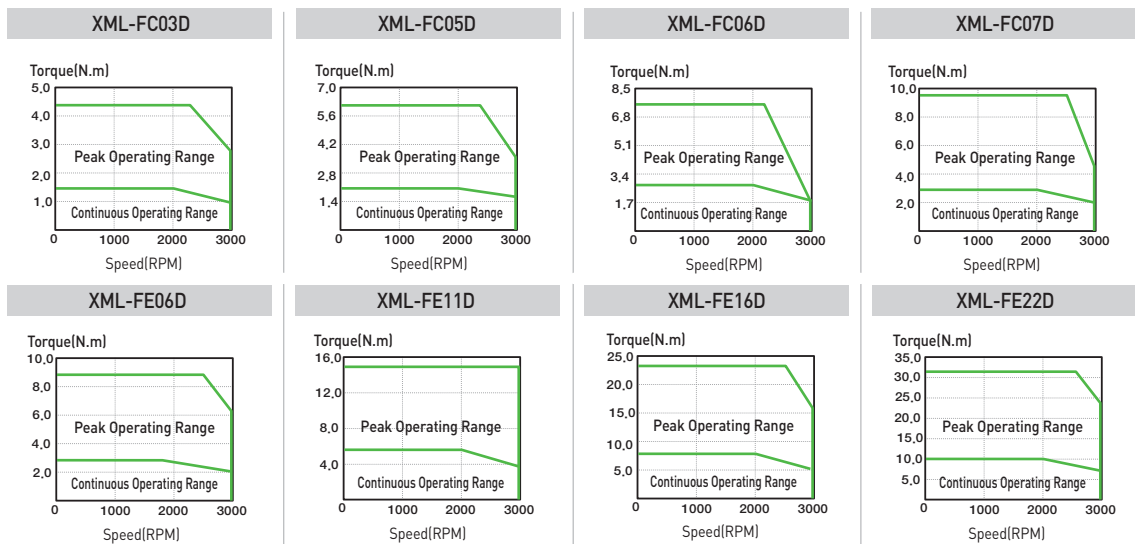

Servo Motor

Motor Specifications [Rated 2000r/min]

Servo Motor (XML-□□□□)		FF22D	FF35D	FF55D	FF75D	FG22D	FG35D	FG55D	FG75D	
Applicable Drive		L7□A020	L7□A035	L7□A050	L7□A075	L7□A020	L7□A035	L7□A050	L7□A075	
Flange Size(□)		□ 180				□ 220				
Rated Output	[kW]	2.2	3.5	5.5	7.5	2.2	3.5	5.5	7.5	
	[N · m]	10.5	16.7	26.25	35.81	10.5	16.71	26.25	35.81	
Rated Torque	[kgf · cm]	107.1	170.4	267.8	365.4	107.1	170.4	267.8	365.4	
	[N · m]	31.5	50.1	78.76	89.53	31.51	50.12	78.76	89.53	
Max. Instantaneous	[kgf · cm]	321.3	511.4	803.4	931.5	321.3	511.3	803.4	913.5	
	[A]	13.07	16.48	28.78	32.95	10.25	14.67	29.74	30.17	
Rated Current	[A]	39.21	49.44	86.34	98.85	30.75	44.01	89.22	90.51	
Max. Current	[A]	2000								
Rated Speed	[r/min]	3000				2500	3000	2700	3000	2500
Max. Speed	[r/min]	2000								
Inertia	[kg · m ² × 10 ⁻⁴]	27.96	45.56	73.85	106.7	41.13	71.53	117.52	149.4	
	[gf · cm · s ²]	28.53	47.51	75.36	108.9	41.97	72.99	120.12	152.45	
Allowable Load Inertia Ratio		5 times of motor inertia								
Rated Power Rate	[kW/s]	39.43	59.89	93.27	120.15	26.78	38.99	58.51	85.83	
Speed/Position Detector	Standard Note1	Serial Type(19bit)								
	Option	×								
Specifications & Features	Structure	Fully closed · Self cooling IP65 Note1								
	Rated Time	Continuous								
	Ambient Temp	Operating : 0 ~ 40[°C] Storage : -10 ~ 60[°C]								
	Ambient Humidity	90[%]RH Below (avoid dew-condensation)								
	Atmosphere	Avoid direct sunlight, no corrosive gas, inflammable gas, oil mist, or dust.								
	E/V	Elevation/vibration 49[m/s ²][5G]								
Weight	[kg]	12.5	17.4	25.12	33.8	15.4	20.2	28.12	33.45	

Note1) Except for axis penetration, when you attach reducer to the motor, we don't guarantee IP for reducer. If you bend over specification designated in cable standard, it is difficult to guarantee IP marked. It can be satisfied protection grade when you use private cable only.

Speed-Torque Characteristics

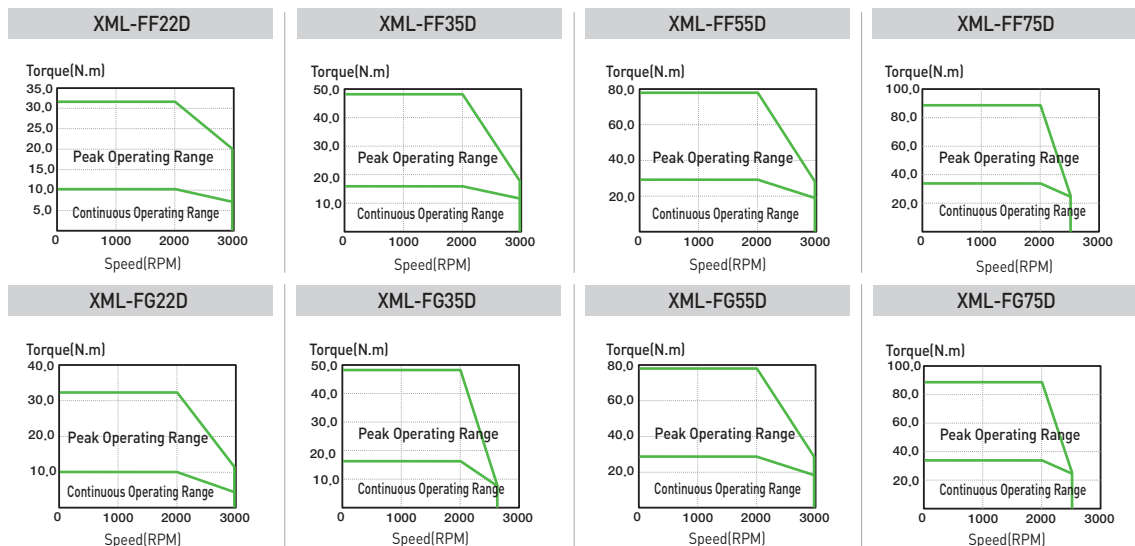

Motor Specifications [Rated1500r/min]

Servo Motor (XML-□□□□)		FE05G	FE09G	FE13G	FE17G	FF20G	FF30G	FF44G	FF60G	FF75G	FG20G	FG30G	FG44G	FG60G	
Applicable Drive		L7□A008	L7□A010	L7□A020		L7□A020	L7□A035	L7□A050	L7□A075	L7□A075	L7□A020	L7□A035	L7□A050	L7□A075	
Flange Size(□)		□ 130				□ 180				□ 220					
Rated Output	[kW]	0.45	0.85	1.3	1.7	1.8	2.9	4.4	6	7.5	1.8	2.9	4.4	6	
Rated Torque	[N · m]	2.86	5.41	8.27	10.82	11.45	18.46	28	38.2	47.7	11.5	18.5	28	38.2	
	[kgf · cm]	29.22	55.19	84.41	110.38	116.9	188.3	285.7	389.8	487.2	116.9	188.4	285.8	389.7	
Max. Instantaneous	[N · m]	8.59	16.23	24.82	32.46	34.35	55.38	84.03	95.5	143.2	34.4	55.4	84	95.5	
	[kgf · cm]	87.66	165.57	253.23	331.14	350.6	564.9	851.1	974.9	1462	350.8	565.1	857.4	974.3	
Rated Current	[A]	4.56	6.67	11.9	13.36	12.16	15.98	30.7	35.14	35.26	11.18	16.21	31.72	32.18	
Max. Current	[A]	13.68	20.01	35.7	40.08	36.48	47.94	92.1	105.42	105.78	33.54	48.63	95.16	96.54	
Rated Speed	[r/min]	1500													
Max. Speed	[r/min]	3000				3000	2700	3000	2500	2200	3000	2700	3000	2500	
Inertia	[kg · m ² X 10 ⁻⁴]	5.66	10.18	14.62	19.04	27.96	46.56	73.85	106.7	131.3	14.13	71.53	117.72	149.4	
	[gf · cm · s ²]	5.77	10.39	14.92	19.43	28.53	47.51	75.36	108.9	134	41.97	72.99	120.12	152.45	
Allowable Load Inertia Ratio		10 times of motor inertia					5 times of motor inertia								
Rated Power Rate	[kW/s]	14.49	28.74	46.81	61.46	46.92	73.14	106.15	136.73	173.63	31.91	47.66	66.64	97.63	
Speed/Position Detector	Standard Note1	Serial Type 19[Bit]													
	Option	×													
Specifications & Features	Structure	Fully closed · Self cooling IP65 Note1													
	Rated Time	Continuous													
	Ambient Temp	Operating : 0 ~ 40[°C] Storage : -10 ~ 60[°C]													
	Ambient Humidity	90[%]RH Below [avoid dew-condensation]													
	Atmosphere	Avoid direct sunlight, no corrosive gas, inflammable gas, oil mist, or dust.													
	E/V	Elevation/vibration 49[m/s ²][5G]													
Weight	[kg]	5.0	6.7	8.5	10.1	12.5	17.4	25.2	33.8	38.5	15.4	20.2	28	33.45	

Note1) Except for axis penetration, when you attach reducer to the motor, we don't guarantee IP for reducer. If you bend over specification designated in cable standard, it is difficult to guarantee IP marked It can be satisfied protection grade when you use private cable only.

Servo Motor

Speed-Torque Characteristics

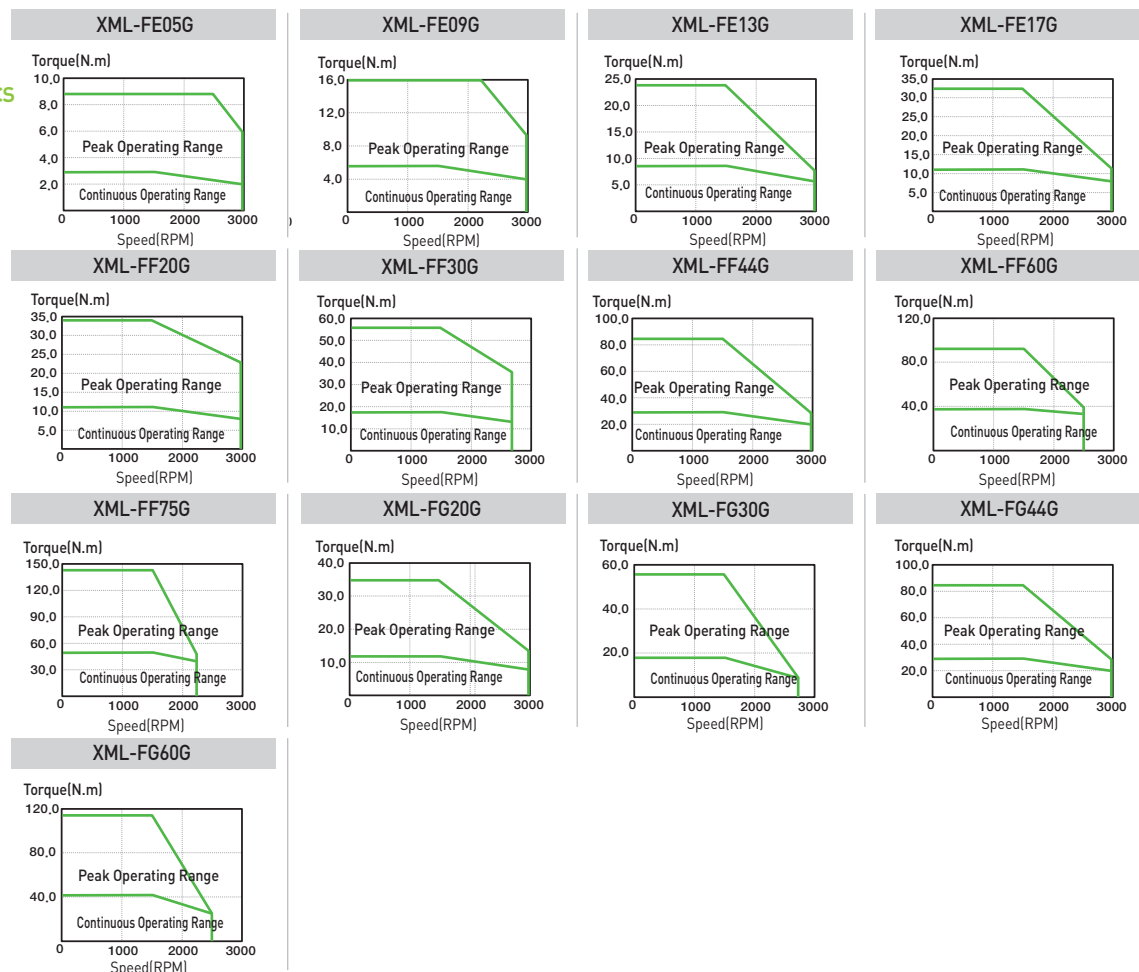

Motor Specifications [Rated 1000r/min]

Servo Motor (XML-□□□□)	FE03M	FE06M	FE09M	FE12M	FF12M	FF20M	FF30M	FF44M	FG12M	FG20M	FG30M	FG44M				
Applicable Drive	L7□A004	L7□A008	L7□A010	L7□A020	L7□A020	L7□A035	L7□A050	L7□A020	L7□A035	L7□A050	L7□A035	L7□A050				
Flange Size(□)	□ 130				□ 180				□ 220							
Rated Output [kW]	0.3	0.6	0.9	1.2	1.2	2	3	4.4	1.2	2	3	4.4				
Rated Torque	[N · m]	2.86	5.72	8.59	11.46	11.46	19.09	28.64	42.02	11.5	19.1	28.6	42			
	[kgf · cm]	29.22	58.4	87.7	116.9	116.9	194.8	292.2	428.7	116.9	194.9	292.3	428.7			
Max. Instantaneous	[N · m]	8.59	17.18	25.77	34.22	34.38	57.29	85.94	126.1	34.4	57.3	85.9	126			
	[kgf · cm]	87.66	175.3	262.9	349.1	350.7	584.4	876.6	128.6	350.8	584.6	876.9	128.61			
Rated Current [A]	2.73	4.56	6.18	10.67	11.1	12.96	16.58	30.6	11.28	13.1	15.52	27.26				
Max. Current [A]	8.19	13.68	18.54	32.01	33.03	38.88	49.74	91.8	33.84	39.3	46.56	81.78				
Rated Speed [r/min]	1000															
Max. Speed [r/min]	2000				1700				2000				1700		2000	
Inertia	[kg · m ² X 10 ⁻⁴]	5.66	10.18	14.62	19.04	27.96	46.56	73.85	106.7	41.13	71.53	117.72	149.4			
	[gf · cm · s ²]	5.77	10.39	14.92	19.43	28.53	47.51	75.36	108.9	41.97	72.99	120.12	152.45			
Allowable Load Inertia Ratio	10 times of motor inertia				5 times of motor inertia											
Rated Power Rate [kW/s]	14.49	32.33	50.48	68.91	46.94	78.27	111.04	165.38	31.91	51	69.7	118.14				
Speed/Position Detector	Standard Note1	Serial Type 19[Bit]														
	Option	×														
Specifications & Features	Structure	Fully closed · Self cooling IP65 Note1														
	Rated Time	Continuous														
	Ambient Temp	Operating : 0 ~ 40[°C] Storage : -10 ~ 60[°C]														
	Ambient Humidity	90[%]RH Below (avoid dew-condensation)														
	Atmosphere	Avoid direct sunlight, no corrosive gas, inflammable gas, oil mist, or dust.														
Weight [kg]	Elevation/vibration 49[m/s ²][5G]															
		5	6.7	8.5	10.1	12.5	17.4	25.2	33.8	15.4	20.2	28	33.5			

Note1) Except for axis penetration, when you attach reducer to the motor, we don't guarantee IP for reducer. If you bend over specification designated in cable standard, it is difficult to guarantee IP marked. It can be satisfied protection grade when you use private cable only.

Speed-Torque Characteristics

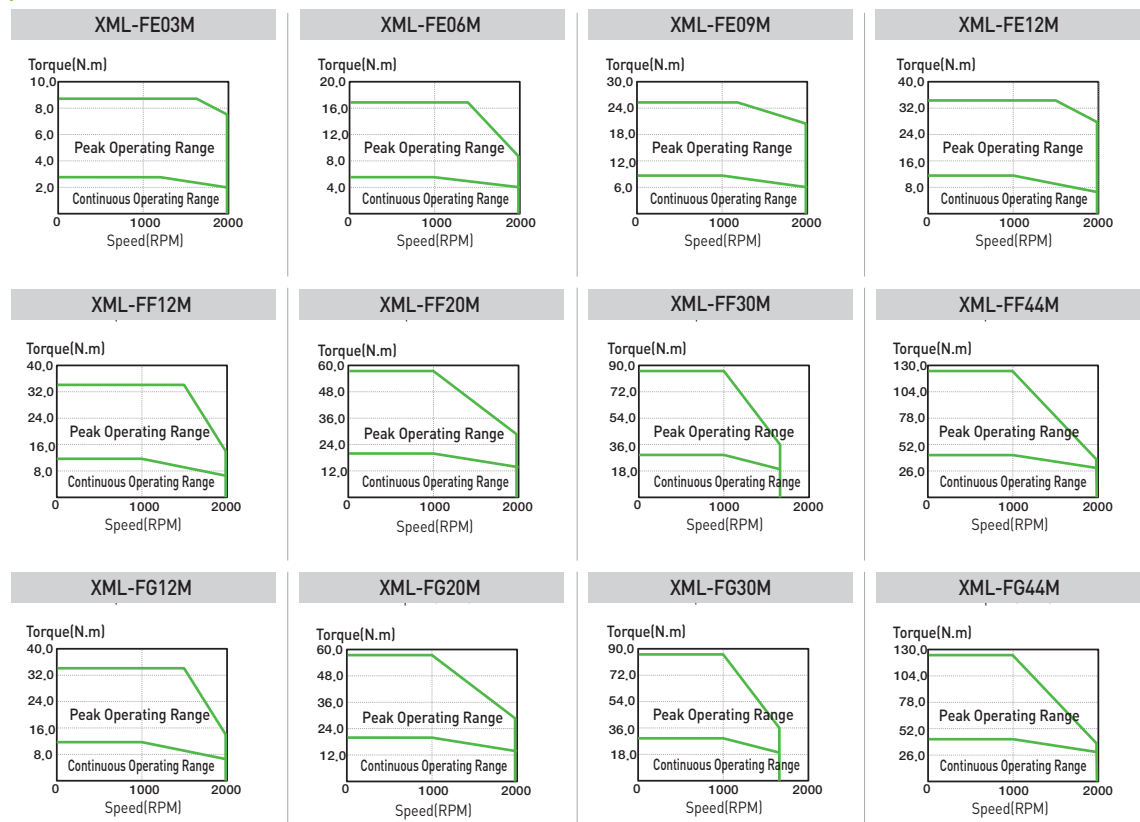

Motor Specifications [Rated 3000r/min]

Servo Motor (XML-□□□□)		FEP09A	FEP15A	FEP22A	FEP30A	FFP30A	FFP50A
Applicable Drive		L7□B010□	L7□B020□	L7□B035□		L7□B050□	
Flange Size(□)		□ 130				□ 180	
Rated Output	[kW]	0.9	1.5	2.2	3	3	5
Rated Torque	[N · m]	2.86	4.77	7	9.55	9.55	15.92
	[kgf · cm]	29.33	48.72	71.46	97.44	97.44	162.4
Max. Instantaneous	[N · m]	8.59	14.32	20.01	28.65	28.65	38.79
	[kgf · cm]	87.7	146.16	214.37	292.33	292.33	406.01
Rated Current	[A]	3.47	6.68	9.12	9.94	9.79	16.07
Max.Current	[A]	10.4	20.03	27.35	29.81	29.38	48.22
Rated Speed	[r/min]	3000					
Max. Speed	[r/min]	5000					
Inertia	[kg · m ² X 10 ⁻⁴]	5.659	10.179	14.619	19.04	27.96	46.56
	[gf · cm · s ²]	5.774	10.387	14.917	19.429	28.531	47.51
Allowable Load Inertia Ratio		10 times of motor inertia				5 times of motor inertia	
Rated Power Rate	[kW/s]	14.5	22.4	33.55	47.89	32.61	54.4
Speed/Position Detector	Standard Note1	Serial Type 19[Bit]					
	Option	×					
Specifications & Features	Structure	Fully closed · Self cooling IP65 Note1					
	Rated Time	Continuous					
	Ambient Temp	Operating : 0 ~ 40[°C] Storage : -10 ~ 60[°C]					
	Ambient Humidity	90[%]RH Below (avoid dew-condensation)					
	Atmosphere	Avoid direct sunlight, no corrosive gas, inflammable gas, oil mist, or dust.					
	E/V	Elevation/vibration 49[m/s2][5G]					
Weight	[kg]	5.5	7.54	9.68	11.78	12.4	17.7

Note1) Except for axis penetration, when you attach reducer to the motor, we don't guarantee IP for reducer. If you bend over specification designated in cable standard, it is difficult to guarantee IP marked It can be satisfied protection grade when you use private cable only.

Servo Motor

Speed-Torque Characteristics

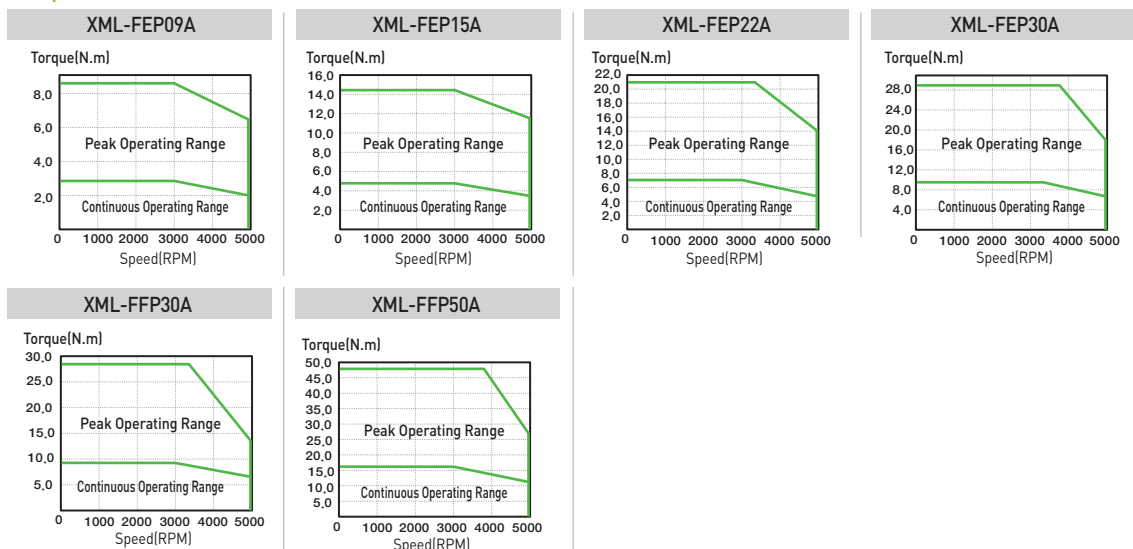

Motor Specifications [Rated 2000r/min]

Servo Motor (XML-□□□□)		FEP06D	FEP11D	FEP16D	FEP22D	FFP22D	FFP35D	FFP55D	FFP75D	FGP22D	FGP35D	FGP55D	FGP75D	FGP110D	
Applicable Drive		L7□B010□				L7□B020□		L7□B035□	L7□B050□	L7□B075□	L7□B020□	L7□B035□	L7□B050□	L7□B075□	L7□B150□
Flange Size(□)		□130				□180				□220					
Rated Output	[kW]	0.6	1.1	1.6	2.2	2.2	3.5	5.5	7.5	2.2	3.5	5.5	7.5	11	
Rated Torque	[N · m]	2.86	5.25	7.64	10.5	10.5	16.71	26.26	35.81	10.5	16.71	26.26	35.81	52.52	
	[kgf · cm]	29.23	53.59	77.95	107.19	107.19	170.52	267.96	365.41	107.19	170.52	267.96	365.41	535.93	
Max. Instantaneous	[N · m]	8.59	15.76	22.92	31.51	31.51	50.13	65.65	89.52	31.51	50.13	78.78	89.52	131.30	
	[kgf · cm]	87.7	160.78	233.86	321.56	321.56	511.57	669.91	913.52	321.56	511.57	803.89	913.52	1339.82	
Rated Current	[A]	3.28	3.4	4.97	6.80	6.93	9.09	14.70	18.97	7.12	8.73	16.04	19.10	27.41	
Max.Current	[A]	9.83	10.19	14.92	20.4	20.8	27.26	44.1	47.42	21.35	26.2	48.11	47.76	67.33	
Rated Speed	[r/min]	2000													
Max. Speed	[r/min]	2000						2500		3000	2700	3000	2500		
Inertia	[kg · m ² X 10 ⁻⁴]	5.659	10.179	14.619	19.04	27.96	46.56	73.85	106.73	41.13	71.53	117.72	149.4	291.36	
	[gf · cm · s ²]	5.774	10.387	14.917	19.429	28.531	47.51	75.357	108.908	41.67	72.99	120.12	152.45	297.31	
Allowable Load Inertia Ratio		10 times of motor inertia					5 times of motor inertia								
Rated Power Rate	[kW/s]	14.5	27.1	39.92	57.95	39.46	59.98	93.38	120.15	26.83	39.04	58.58	85.83	94.65	
Speed/Position Detector	Standard <i>Note1</i>	Serial Type 19[Bit]													
	Option	×													
Specifications & Features	Structure	Fully closed · Self cooling IP65 <i>Note1</i>													
	Rated Time	Continuous													
	Ambient Temp	Operating : 0 ~ 40[°C] Storage : -10 ~ 60[°C]													
	Ambient Humidity	90[%]RH Below [avoid dew-condensation]													
	Atmosphere	Avoid direct sunlight, no corrosive gas, inflammable gas, oil mist, or dust.													
	E/V	Elevation/vibration 49[m/s ²][5G]													
Weight	[kg]	5.5	7.54	9.68	11.78	12.4	17.7	26.3	35.6	16.95	21.95	30.8	37.52	66.2	

Note1) Except for axis penetration, when you attach reducer to the motor, we don't guarantee IP for reducer. If you bend over specification designated in cable standard, it is difficult to guarantee IP marked It can be satisfied protection grade when you use private cable only.

Speed-Torque Characteristics

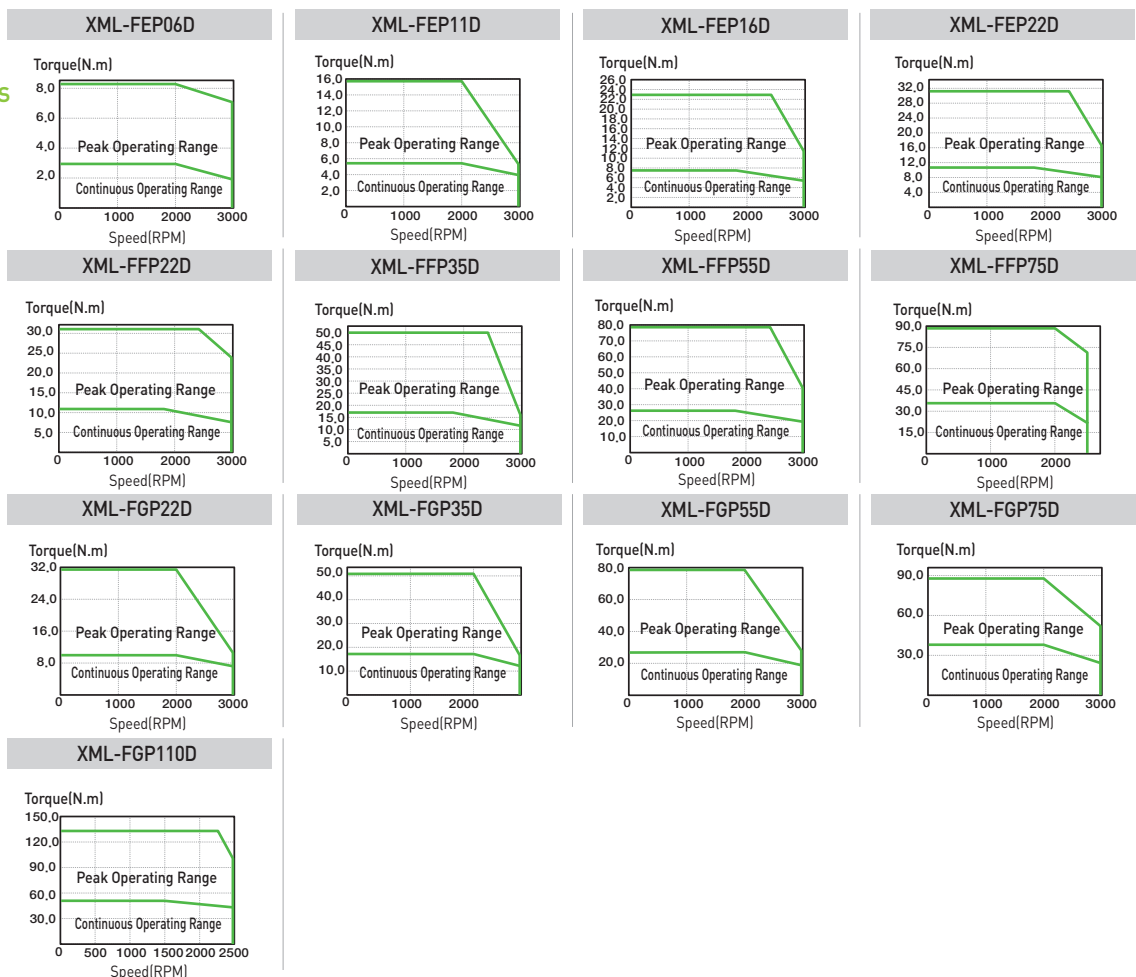

Motor Specifications [Rated 1500r/min]

Servo Motor (XML-□□□□)		FEP05G	FEP09G	FEP13G	FEP17G	FFP20G	FFP30G	FFP44G	FFP75G	FGP20G	FGP30G	FGP44G	FGP60G	FGP85G	FGP110G	FGP150G		
Applicable Drive		L7□B010□				L7□B020□				L7□B035□		L7□B050□		L7□B075□		L7□B150□		
Flange Size (□)		□130				□180				□220								
Rated Output	[kW]	0.45	0.85	1.3	1.7	1.8	2.9	4.4	6	7.5	1.8	2.9	4.4	6	8.5	11	15	
Rated Torque	[N · m]	2.86	5.41	8.28	10.82	11.46	18.46	28.01	38.2	47.75	11.46	18.46	28.01	38.2	54.11	70.03	95.49	
	[kgf · cm]	29.23	55.22	84.45	110.43	116.93	188.39	285.83	389.77	487.21	116.93	188.39	285.83	389.77	552.17	714.57	974.42	
Max. Instantaneous	[N · m]	8.59	16.23	24.83	32.47	34.38	55.39	84.03	95.49	119.37	34.38	55.39	84.03	95.49	135.28	175.07	238.73	
	[kgf · cm]	87.7	166.65	253.35	331.3	350.79	565.16	857.49	974.42	1,218.02	350.79	565.16	857.49	974.42	1,380.43	1,786.43	2,436.05	
Rated Current	[A]	3.28	3.50	5.39	7.01	7.56	10.14	15.68	20.23	20.01	7.76	9.65	17.11	20.38	28.24	28.28	35.71	
Max. Current	[A]	9.83	10.5	16.16	21.02	22.69	30.12	47.04	50.58	50.03	23.29	28.95	51.32	50.95	69.37	68.83	87.7	
Rated Speed	[r/min]	1500																
Max. Speed	[r/min]	3000				2700		3000	2500	2200	3000	2700	3000	2500	2000			
Inertia	[kg · m ² × 10 ⁻⁴]	5.659	10.179	14.619	19.04	27.96	46.56	73.85	106.73	131.29	51.42	80.35	132.41	172.91	291.36	51.42	424.5	
	[gf · cm · s ²]	5.774	10.387	14.917	19.429	28.531	47.51	75.357	108.908	133.969	52.47	81.99	135.11	176.44	297.31	52.47	433.2	
Allowable Load Inertia Ratio		10 times of motor inertia								5 times of motor inertia								
Rated Power Rate	[kW/s]	14.5	28.77	46.85	61.52	46.96	73.21	106.25	136.7	173.64	25.53	45.39	61.97	102.08	100.5	168.3	214.8	
Speed/Position Detector	Standard Note1	Serial Type 19[Bit]																
	Option	×																
Specifications & Features	Structure	Fully closed · Self cooling IP65 Note1																
	Rated Time	Continuous																
	Ambient Temp	Operating : 0 ~ 40[°C] Storage : -10 ~ 60[°C]																
	Ambient Humidity	90[%]RH Below [avoid dew-condensation]																
	Atmosphere	Avoid direct sunlight, no corrosive gas, inflammable gas, oil mist, or dust.																
	E/V	Elevation/vibration 49[m/s ²][5G]																
Weight	[kg]	5.5	7.54	9.68	11.78	12.4	17.7	26.3	35.6	39.4	16.95	21.95	30.8	37.52	66.2	66.3	92.2	

Note1) Except for axis penetration, when you attach reducer to the motor, we don't guarantee IP for reducer. If you bend over specification designated in cable standard, it is difficult to guarantee IP marked. It can be satisfied protection grade when you use private cable only.

Servo Motor

Speed-Torque Characteristics

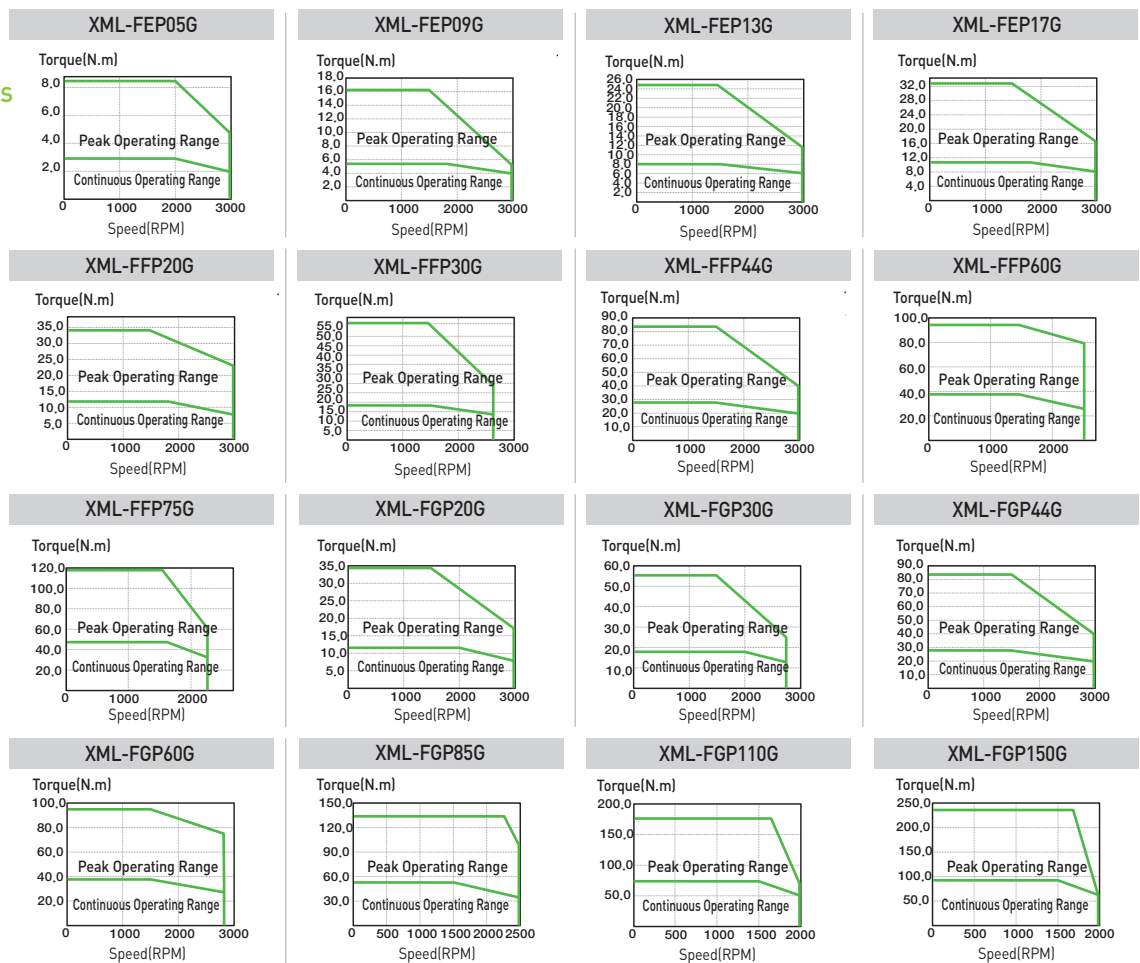

Motor Specifications [Rated 1000r/min]

Servo Motor (XML-□□□□)	FEP03M	FEP06M	FEP09M	FEP12M	FFP12M	FFP20M	FFP30M	FFP44M	FGP12M	FGP20M	FGP30M	FGP44M	
Applicable Drive	L7□B010□			L7□B020□			L7□B050□		L7□B020□		L7□B050□		
Flange Size(□)	□130				□180				□220				
Rated Output	[kW]	0.3	0.6	0.9	1.2	1.2	2	3	4.4	1.2	2	3	4.4
Rated Torque	[N · m]	2.86	5.73	8.59	11.46	11.46	19.1	28.65	42.02	11.46	19.1	28.65	42.02
	[kgf · cm]	29.23	58.47	87.7	116.93	116.93	194.88	292.33	428.74	116.93	194.88	292.33	428.74
Max. Instantaneous	[N · m]	8.59	17.19	25.78	34.38	34.38	57.3	85.94	126.05	34.38	57.3	85.94	126.05
	[kgf · cm]	87.7	175.4	263.09	350.79	350.79	584.65	876.98	1286.23	350.79	584.65	876.98	1,071.86
Rated Current	[A]	3.28	3.28	3.33	4.87	4.83	7.94	11.9	16.69	4.75	7.88	11.74	17.39
Max. Current	[A]	9.83	9.83	9.99	14.6	14.5	23.83	35.7	50.08	14.24	23.564	35.22	52.18
Rated Speed	[r/min]	1000											
Max. Speed	[r/min]	2000				1700				2000			
Inertia	[kg · m ² X 10 ⁻⁴]	5.659	10.179	14.619	19.04	27.96	46.56	73.85	106.73	51.42	80.35	132.41	172.91
	[gf · cm · s ²]	5.774	10.387	14.917	19.429	28.53	47.51	75.357	108.908	52.47	81.99	135.11	176.44
Allowable Load Inertia Ratio		10 times of motor inertia				5 times of motor inertia							
Rated Power Rate	[kW/s]	14.5	32.25	50.53	68.97	46.96	78.38	111.13	165.41	25.53	45.39	61.97	102.08
Speed/Position Detector	Standard Note1	Serial Type 19[Bit]											
	Option	×											
Specifications & Features	Structure	Fully closed · Self cooling IP65 Note1											
	Rated Time	Continuous											
	Ambient Temp	Operating : 0 ~ 40[°C] Storage : -10 ~ 60[°C]											
	Ambient Humidity	90[%]RH Below (avoid dew-condensation)											
	Atmosphere	Avoid direct sunlight, no corrosive gas, inflammable gas, oil mist, or dust.											
	E/V	Elevation/vibration 49[m/s ²][5G]											
Weight	[kg]	5.5	7.54	9.68	11.78	12.4	17.7	26.3	35.6	16.95	21.95	30.8	37.52

Note1) Except for axis penetration, when you attach reducer to the motor, we don't guarantee IP for reducer. If you bend over specification designated in cable standard, it is difficult to guarantee IP marked It can be satisfied protection grade when you use private cable only.

Speed-Torque Characteristics

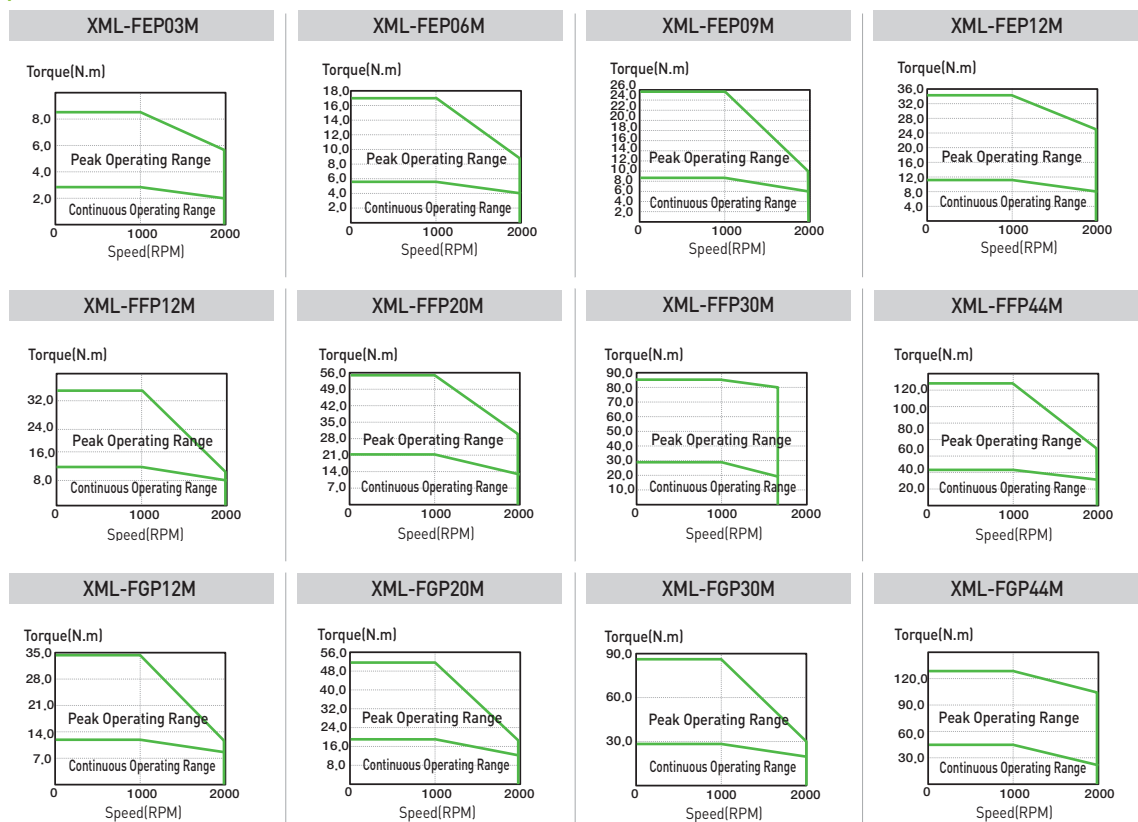

FAL Series

Plug Specifications

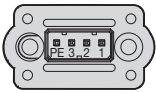

Power

Pin No.	Color	Signal
1	Red	U
2	White	V
3	Black	W
4	Green	Ground

[Power Connector Pin Table]

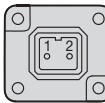

Brake

Pin No.	Signal
1	BK+
2	BK-

[Brake Connector Pin Table]

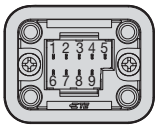

Encoder

Multi Turn (M)	
Pin No.	Signal
1	MA
2	SLO
3	-
4	OV
5	SHIELD
6	MA
7	SLO
8	-
9	+5V

[Encoder Connector Pin Table]

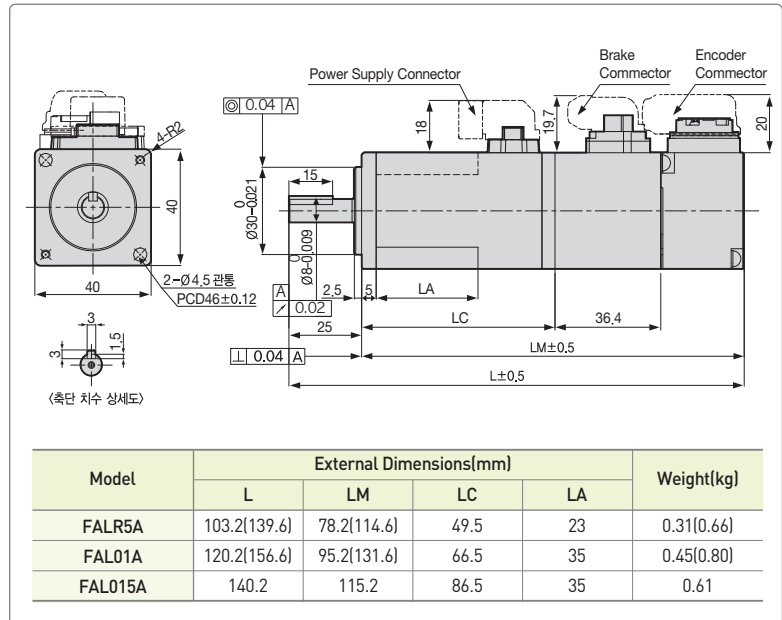

Note1) Use DC[24V] for brake input power supply. Note2) The [] is for brake-attached type. Note3) For external dimensions for oil-sealed type. Please kindly contact us separately.

FBL Series

Plug Specifications

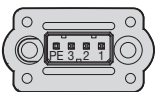

Power

Pin No.	Color	Signal
1	Red	U
2	White	V
3	Black	W
4	Green	Ground

[Power Connector Pin Table]

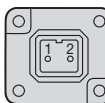

Brake

Pin No.	Signal
1	BK+
2	BK-

[Brake Connector Pin Table]



Encoder

Multi Turn (M)	
Pin No.	Signal
1	MA
2	SLO
3	GND_B
4	OV
5	SHIELD
6	MA
7	SLO
8	VDD_B
9	+5V

[Encoder Connector Pin Table]

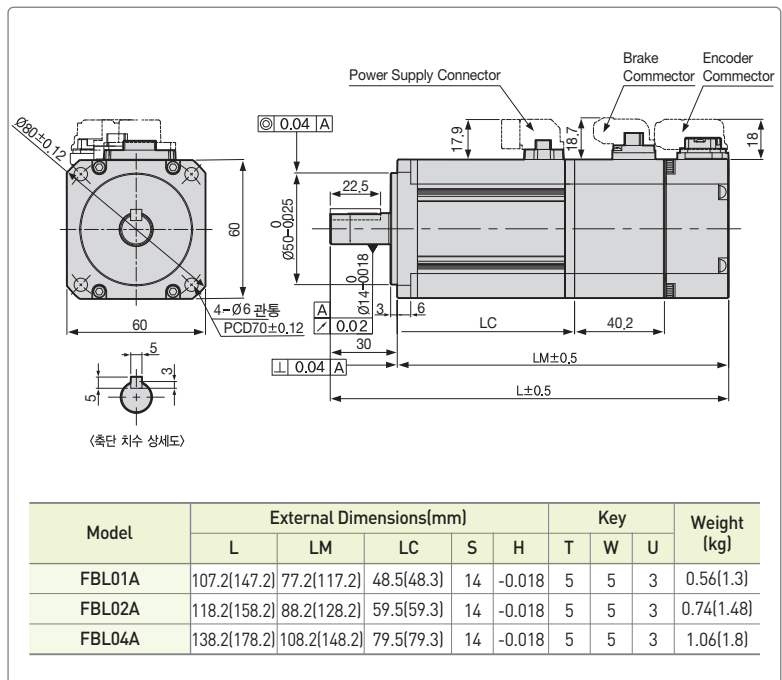

Note1) Use DC[24V] for brake input power supply. Note2) The [] is for brake-attached type. Note3) For external dimensions for oil-sealed type. Please kindly contact us separately.

FCL Series

Plug Specifications

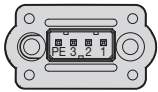

Power

Pin No.	Color	Signal
1	Black	U
2	White	V
3	Red	W
PE	Green	Ground

(Power Connector Pin Table)

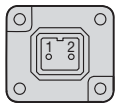

Brake

Pin No.	Signal
1	BK+
2	BK-

(Brake Connector Pin Table)



Encoder

Pin No.	Multi Turn (M)	
	Signal	
1	MA	
2	SLO	
3	GND_B	
4	OV	
5	SHIELD	
6	MA	
7	SLO	
8	VDD_B	
9	+5V	

(Encoder Connector Pin Table)

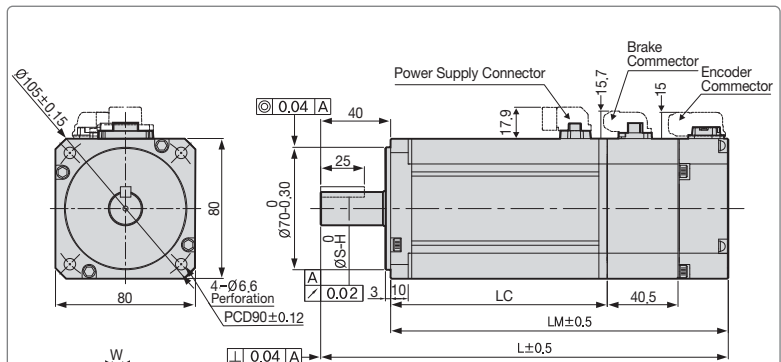

(Cross section of shaft key)

Model	External Dimensions(mm)							Weight(kg)	
	L	LM	LC	S	H	T	W		
FCL04A, FCL03D	138.7(179.5)	98.7(139.5)	70(69.8)	14	-0.018	5	5	3	1.52(2.32)/1.26(2.06)
FCL06A, FCL05D	156.7(197.5)	116.7(157.5)	88(87.8)	19	-0.021	6	6	3.5	2.14(2.94)/2.12(2.92)
FCL08A, FCL06D	174.7(215.5)	134.7(175.5)	106(105.8)	19	-0.021	6	6	3.5	2.68(3.48)/2.66(3.46)
FCL10A, FCL07D	192.7(233.5)	152.7(193.5)	124(123.8)	19	-0.021	6	6	3.5	3.30(4.10)/2.78(3.58)

Note1) Use DC[24V] for brake input power supply. Note2) The [] is for brake-attached type. Note3) For external dimensions for oil-sealed type. Please kindly contact us separately.

FB Series

Plug Specifications

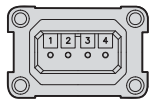

Power

Pin No.	Color	Signal
1	Black	W
2	White	V
3	Red	U
4	Green	Ground

(Power Connector Pin Table)

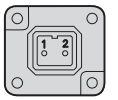

Brake

Pin No.	Signal
1	BK+
2	BK-

(Brake Connector Pin Table)



Encoder

Pin No.	Multi Turn (M)	
	Signal	
1	MA	
2	SLO	
3	GND_B	
4	OV	
5	SHIELD	
6	MA	
7	SLO	
8	VDD_B	
9	+5V	

(Encoder Connector Pin Table)

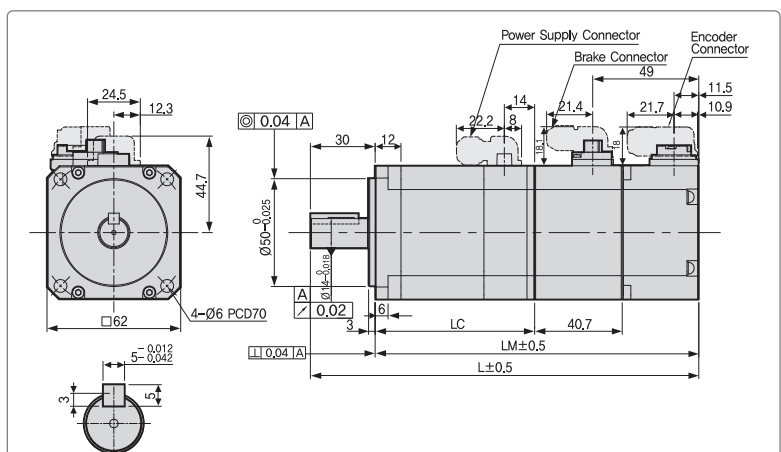

(Cross section of shaft key S/C 2:1)

Model	External Dimensions(mm)			Weight(kg)
	L	LM	LC	
FB01A	109(149.2)	79(119.2)	43.5(43)	0.72(1.27)
FB02A	120(160.2)	90(130.2)	54.5(54)	0.94(1.49)
FB04A	140(180.2)	110(150.2)	74.5(74)	1.32(1.87)

Note1) Use DC[24V] for brake input power supply. Note2) The [] is for brake-attached type. Note3) For external dimensions for oil-sealed type. Please kindly contact us separately.

FC Series

Plug Specifications

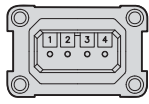

Power

Pin No.	Color	Signal
1	Black	W
2	White	V
3	Red	U
4	Green	Ground

[Power Connector Pin Table]

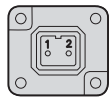

Brake

Pin No.	Signal
1	BK+
2	BK-

[Brake Connector Pin Table]



Encoder

Single Turn (N)		Multi Turn (M)	
Pin No.	Signal	Pin No.	Signal
1	MA	1	MA
2	SLO	2	SLO
3	-	3	GND_B
4	OV	4	OV
5	SHIELD	5	SHIELD
6	MA	6	MA
7	SLO	7	SLO
8	-	8	VDD_B
9	+5V	9	+5V

[Encoder Connector Pin Table]

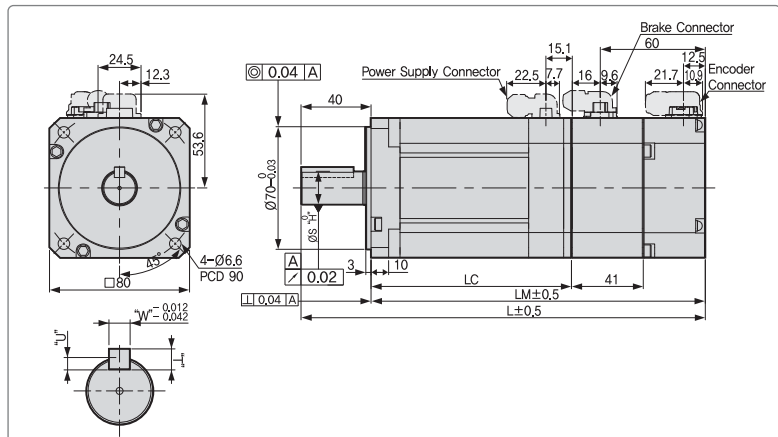

(Cross section of shaft key S/C 2:1)

Model	External Dimensions(mm)							Weight(kg)	
	L	LM	LC	S	H	T	W		U
FC04A, FC03D	136.5(177)	96.5(137)	61(60.5)	14	-0.018	5	5	3	1.56(2.6)
FC06A, FC05D	154.5(195)	114.5(155)	79(78.5)	19	-0.021	6	6	3.5	2.18(3.22)
FC08A, FC06D	172.5(213)	132.5(173)	97(96.5)	19	-0.021	6	6	3.5	2.72(3.76)
FC10A, FC07D	190.5(231)	150.5(191)	115(114.5)	19	-0.021	6	6	3.5	3.80(4.34)

Note1) Use DC[24V] for brake input power supply. Note2) The [] is for brake-attached type. Note3) For external dimensions for oil-sealed type. Please kindly contact us separately.

FE, FEP Series

Plug Specifications

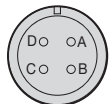

Spec.: MS3102A20-4P (Standard)

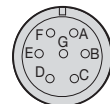

Spec.: MS3102A20-15P (Brake-attached type)

Power

Pin No.	Signal
A	U
B	V
C	W
D	Ground

Pin No.	Signal	Pin No.	Signal
A	U	D	Ground
B	V	E	BK+
C	W	F	BKPin

Pin No.	Signal	Pin No.	Signal
A	MA	M	-
B	MA	N	-
C	SLO	P	-
D	SLO	R	-
E	-	H	+5V
F	-	G	OV
K	-	J	SHIELD
L	-	-	-

[Single Turn Encoder Connector Pin Table]

2. Serial type



Spec.: MS3102A20-29P

Encoder

Pin No.	Signal	Pin No.	Signal
A	MA	M	-
B	MA	N	-
C	SLO	P	-
D	SLO	R	-
E	VDD_B	H	+5V
F	GND_B	G	OV
K	-	J	SHIELD
L	-	-	-

[Multi Turn Encoder Connector Pin Table]

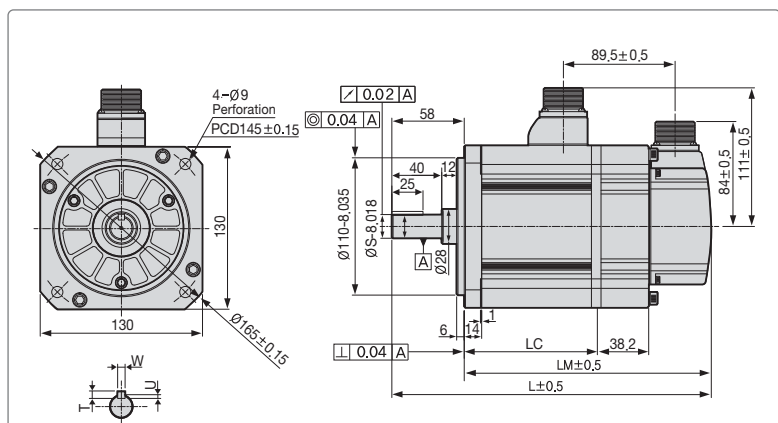

(Cross section of shaft key)

Model	External Dimensions(mm)							Key	Weight(kg)
	L	LM	LC	S	T	W	U		
FE09A, FE06D, FE05G, FE03M, FEP09A, FEP06D, FEP05G, FEP03M	197.3(235.3)	139.3(177.3)	89.8(89.6)	19	5	5	3	5.04(6.58)	
FE15A, FE11D, FE09G, FE06M, FEP15A, FEP11D, FEP09G, FEP06M	217.3(255.3)	159.3(197.3)	109.8(109.6)	19	5	5	3	6.74(8.28)	
FE22A, FE16D, FE13G, FE09M, FEP22A, FEP16D, FEP13G, FEP09M	237.3(275.3)	179.3(217.3)	129.8(129.6)	22	6	6	3.5	8.48(10.02)	
FE30A, FE22D, FE17G, FE12M, FEP30A, FEP22D, FEP17G, FEP12M	255.3(293.3)	197.3(235.3)	147.8(147.6)	24	7	8	4	10.05(11.59)	

Note1) Use DC[24V] for brake input power supply. Note2) The [] is for brake-attached type.

FF, FFP Series

Plug Specifications

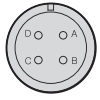

Spec.: MS3102A22-22P
(Standard)

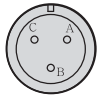

Spec.: MS3102A24-10P
(Brake-attached type)

2. Serial type



Spec.: MS3102A20-29P

Power

Pin No.	Signal
A	U
B	V
C	W
D	Ground

Pin No.	Signal	Pin No.	Signal
A	U	D	Ground
B	V	E	BK+
C	W	F	BK-

Encoder

Pin No.	Signal	Pin No.	Signal
A	MA	M	-
B	MA	N	-
C	SLO	P	-
D	SLO	R	-
E	-	H	+5V
F	-	G	0V
K	-	J	SHIELD
L	-	-	-

(Single Turn Encoder Connector Pin Table)

Pin No.	Signal	Pin No.	Signal
A	MA	M	-
B	MA	N	-
C	SLO	P	-
D	SLO	R	-
E	VDD_B	H	+5V
F	GND_B	G	0V
K	-	J	SHIELD
L	-	-	-

(Multi Turn Encoder Connector Pin Table)

- Note1] FF30M or above models have eye bolts.
- Note2] Use DC[24V] for brake input power supply.
- Note3] The () is for brake-attached type.
- Note4] Use MS3102A32-17 for FF75G Power connector.

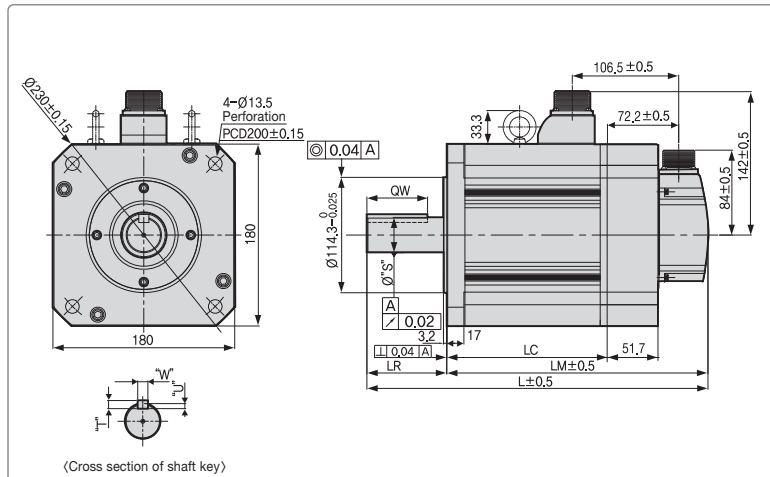

(Cross section of shaft key)

Model	External Dimensions(mm)				Key					Weight(kg)
	L	LM	LC	LR	S	QW	T	W	U	
FF30A, FF22D, FF20G, FF12M FFP30A, FFP22D, FFP20G, FFP12M	257.5(308.9)	178.5(229.9)	129(128.7)							12.5(19.7)
FF50A, FF35D, FF30G, FF20M FFP50A, FFP35D, FFP30G, FFP20M	287.5(338.9)	208.5(259.9)	159(158.7)		35 ^{+0.01} ₀		10			17.4(24.6)
FF55D, FF44G, FF30M FFP55D, FFP44G, FFP30M	331.5(382.9)	252.5(303.9)	203(202.7)	79		60	8		5	25.2(32.4)
FF75D, FF60G, FF44M FFP75D, FFP60G, FFP44M	384.5(435.9)	305.5(356.9)	256(255.7)		42 ⁻⁰ _{0.016}		12			33.8(41.0)
FF75G, FFP75G	439.5	326.5	277	113		96				38.5(45.7)

FG, FGP Series

Plug Specifications

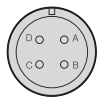

Spec.: MS3102A22-22P
(Standard)

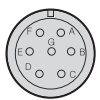

Spec.: 3102A14-7P
(Brake-attached type)

2. Serial type

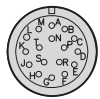

Spec.: MS3102A20-29P

Power

Pin No.	Signal
A	U
B	V
C	W
D	Ground

Pin No.	Signal
A	BK+
B	BK-
C	NC

Encoder

Pin No.	Signal	Pin No.	Signal
A	MA	M	-
B	MA	N	-
C	SLO	P	-
D	SLO	R	-
E	-	H	+5V
F	-	G	0V
K	-	J	SHIELD
L	-	-	-

(Single Turn Encoder Connector Pin Table)

Pin No.	Signal	Pin No.	Signal
A	MA	M	-
B	MA	N	-
C	SLO	P	-
D	SLO	R	-
E	VDD_B	H	+5V
F	GND_B	G	0V
K	-	J	SHIELD
L	-	-	-

(Multi Turn Encoder Connector Pin Table)

- Note1] In case of SG, use DC[90V] for brake input power supply. Note2] The () is for brake-attached type.

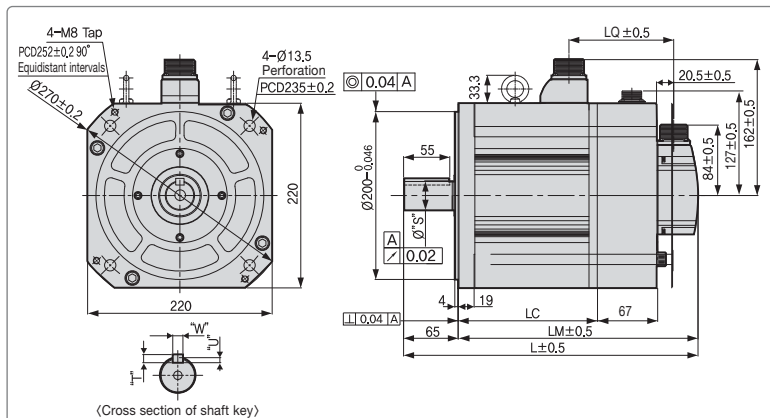

(Cross section of shaft key)

Model	External Dimensions(mm)			Key				Weight(kg)
	L	LM	LC	S	T	W	U	
FG22D, FG20G, FG12M FGP22D, FGP20G, FGP12M	229.5(295.7)	164.5(230.7)	115(114.2)					15.42(29.23)
FG35D, FG30G, FG20M FGP35D, FGP30G, FGP20M	250.5(316.7)	185.5(251.7)	136(135.2)	35 ^{+0.01} ₀	8	10	5	20.22(34.03)
FG55D, FG44G, FG30M FGP55D, FGP44G, FGP30M	282.5(348.7)	217.5(283.7)	168(167.2)					28.02(41.83)
FG75D, FG60G, FG44M FGP75D, FGP60G, FGP44M	304.5(370.7)	239.5(305.7)	190(189.2)	42 ⁻⁰ _{0.016}		12		33.45(47.26)

DD Motor Designation

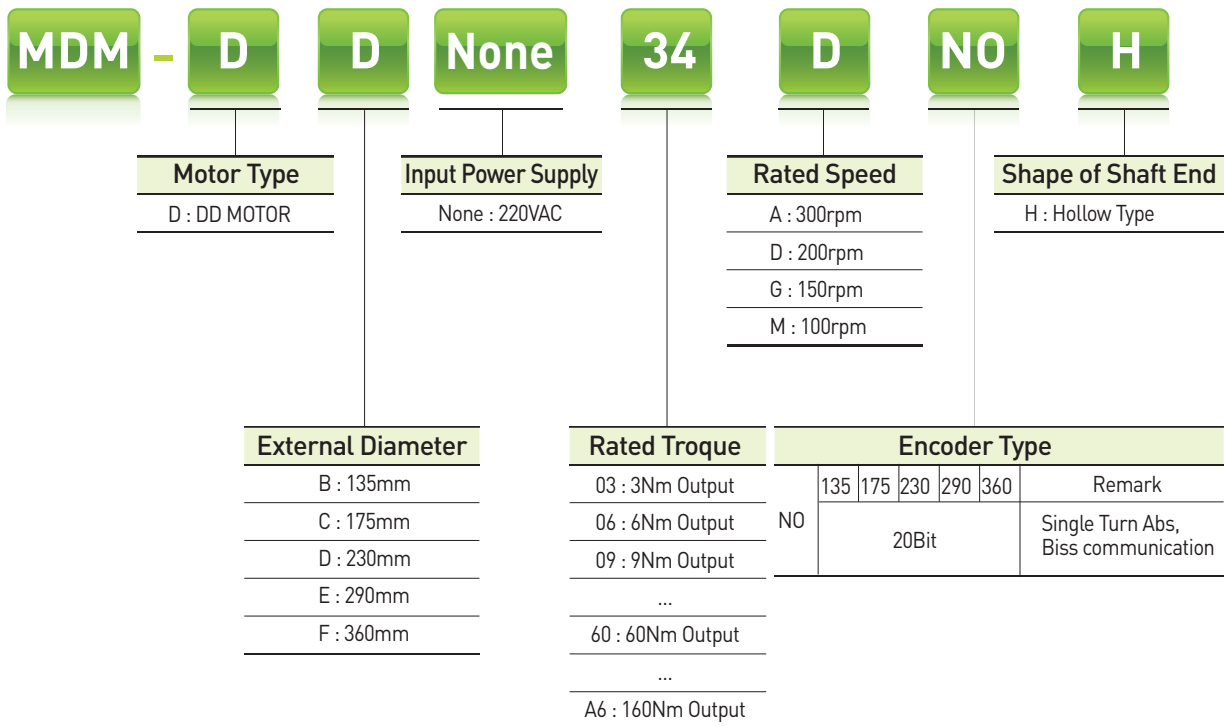

Using the own technologies to produce motors, drives and encoders domestically

Optimized for low-speed, high-torque and high-precision operation

- Providing Power connection for the connection of DC-Link Terminal
- Compact Size and Easy Wiring (Compared with 3 phase AC Reactor)
- Providing Connection for DC Input (PI, N)

Reduced cogging torque and optimized torque design

- Optimal ratio of the permanent magnet and coil / slot selected through electromagnetic analysis
- Using multiple permanent magnets to reduce torque ripple and to maximize torque
- Using a permanent magnet of high-energy rare earth elements (Nd-Fe-B)

Using the high-performance rotary optical encoder that adopts the Biss protocol

- Resolution of 1,048,576 CPR (Single turn Absolute)
- Using our own encoder technology to reduce the cost and shorten the delivery time

Compatible with our L7 Series AC Servo Drive (3phase AC 220V)

- Both standard I/O type (serial communication supported) and network type (EtherCAT) applicable

Direct Drive Structure

- No backlash impact
- High-precision operation and shortened installation time
- Smooth rotary motion
- Reduced noise

Hollow type that is efficient for wiring and piping

A wide range of products

- Rated output: 63W-25kW
- Rated torque: 3.0N.m-160N.m (the instantaneous maximum torque should be 3 times the rated torque)
- Rated speed: 150RPM-200RPM
- Frame diameter: 135mm,175mm,230mm,290mm, and 360mm (13 models)

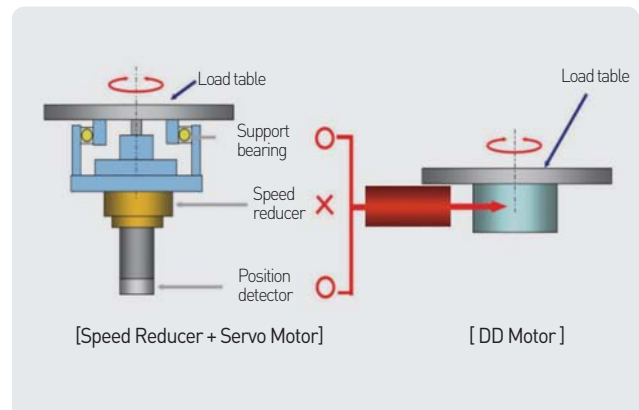







DD Motor Specifications

Ratings and Specifications

- Insulation class : Class B
- Protection class: IP 40
- Cooling type : Fully enclosed self-cooling
- Vibration class : V15
- Insulation resistance : 500 VDC, 10[M Ω] or higher
- Insulation internal voltage: 1800 VAC, 1 second
- Operating voltage: 200 VAC
- Operating temperature : 0 - 40[°C] / Storage temperature: -10~60[°C]
- Ambient humidity : 20 - 80% RH (no condensation)
- Installation location : Place with no toxic substances, such as corrosive and combustible gasses, cutting oil, metal dust, grease or direct sunlight

Line-up Table

Maximum Torque[Nm]			9	18	27	36	54	66	102	120	180	330	480
Rated speed 200[rpm]	Maximum speed 500[rpm]	Ø135	DB03D DB06D DB09D 										
		Ø175		DC06D		DC12D							
		Ø230				DD12D 							
	Maximum speed 400[rpm]	Ø175					DC18D 						
		Ø230					DD22D DD34D 						
	Maximum speed 300[rpm]	Ø290								DE40D DE60D 			
Rated speed 150[rpm]	Maximum speed 250[rpm]	Ø360									DFA1D DFA6D 		

Applicable Drive to Motor

Rated Speed (RPM)	Maximum Speed (RPM)	External Diameter of Motor(∅)	Applicable Motor	Applicable Drive	Standard Encoders	Encoders Cable (Serial)	Power Cable (Power)
200	500	135	DB03D	L7PA001U	* 20Bit Serial	XLCS-E □ □ □ ZS	XLCS-PN □ □ YS
			DB06D	L7PA001U			
			DB09D	L7PA001U			
	400	175	DC06D	L7PA002U			
			DC12D	L7PA002U			
			DC18D	L7PA002U			
	500	230	DD12D	L7PA004U			
			DD22D	L7PA004U			
	400		DD34D	L7PA008U			
	300	290	DE40D	L7PA008U			
DE60D			L7PA010U				
150	250	360	DFA1G	L7PA008U			XLCS-PN □ □ YS
			DFA6G	L7PA020U			

Appearances of Motor



Motor Designation		MDM-DB□□D□□H			MDM-DC□□D□□H		
		03	06	09	06	12	18
Applicable Drive		L7□A001□	L7□A002□	L7□A004□	L7□A002□	L7□A004□	L7□A008□
Flange Size	mm	∅135			∅175		
Rated Output	W	63	126	188	126	251	377
Rated Torque	N-m	3	6	9	6	12	18
Max Torque	N-m	9	18	27	18	36	54
Rated Current	Arms	1.12	1.46	2.63	1.48	2.41	3.0
Max Current	Arms	3.36	4.38	7.89	4.44	7.23	9.0
Rated Speed	rpm	200			200		
Max Speed	rpm	500	500	500	500	500	400
Constant of Torque	N-m/Arms	2.76	4.25	3.57	4.18	5.13	6.12
Inertia	kg-m ² × 10 ⁻⁴	5.74	8.67	11.5	27.32	38.9	50.48
Rated Power Rate	kW/S	15.68	42.35	70.43	13.18	52.71	118.59
Angular acceleration	rad/s ²	191.2	141.6	127.7	455.03	323.9	280.3
Positioning accuracy	arc-sec	±30					
Positioning repeatability	arc-sec	±1.3					
Axial run-out	mm	0.015					
Radial run-out	mm	0.03					
Allowable Thrust Load	N	1500			3300		
Max. Instantaneous	N-m	40			70		
Encoder Type		20-bit single turn serial encoder [Biss/Absolute]					
Weight(Approx.)	kg	6.3	7.2	9.2	8.7	10.6	12.6
Working Environment	Ambient Temp	operating : 0~40[°C] / storage : -20~60[°C]					
	Ambient Humidity	20~80[%] RH[avoid dew-condensation]					
	Atmosphere	Avoid direct sunlight, No corrosive gas, Inflammable gas, Oil mist, or Dust					

* In case of allowable load inertia ratio, please apply within 30 times of rotator inertia

Servo Motor

Speed-Torque Characteristics

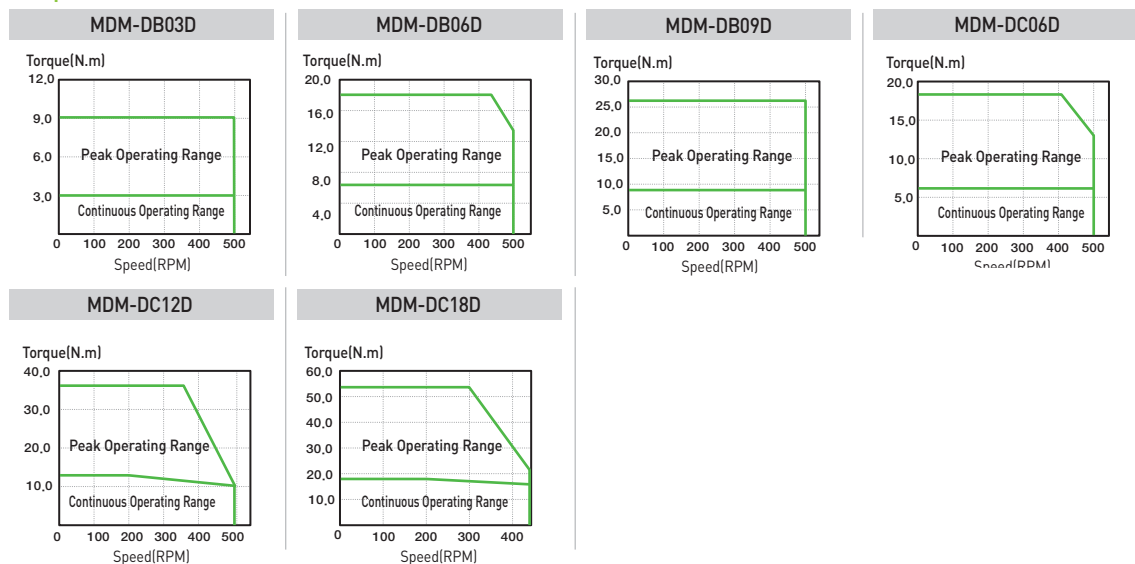

Motor Designation		MDM-DD□□D□□H			MDM-DE□□D□□H		MDM-DF□□G□□H	
		12	22	34	40	60	A1	A6
Applicable Drive		L7□A004□	L7□A008□	L7□A010□	L7□A010□	L7□A020□	L7□A020□	L7□A035□
Flange Size	mm	∅230			∅290		∅360	
Rated Output	W	251	461	712	838	1,257	1,728	2,513
Rated Torque	N-m	12	22	34	40	60	110	160
Max Torque	N-m	36	66	102	120	180	330	480
Rated Current	Arms	2.58	3.33	5.72	5.3	8.33	9.48	14.6
Max Current	Arms	7.74	9.99	17.16	15.9	24.99	28.44	43.8
Rated Speed	rpm	200			200		150	
Max Speed	rpm	500	400	400	300	300	250	250
Constant of Torque	N-m/Arms	4.8	6.81	6.13	7.77	7.42	11.95	11.29
Inertia	kg-m ² × 10 ⁻⁴	54.14	68.15	82.16	311.55	371.71	1410.2	1763.4
Rated Power Rate	kW/S	26.6	71.02	140.7	51.36	96.68	85.9	145.4
Angular acceleration	rad/s ²	450.9	309.6	241.5	778.35	619.1	1281.13	1101.4
Positioning accuracy	arc-sec	±30						
Positioning repeatability	arc-sec	±1.3						
Axial run-out	mm	0.015						
Radial run-out	mm	0.03						
Allowable Thrust Load	N	4000			1100		15000	
Max. Instantaneous	N-m	93			250		350	
Encoder Type		20-bit single turn serial encoder [Biss/Absolute]						
Weight(Approx.)	kg	17.3	19.6	21.9	28.2	35	54	70.3
Working Environment	Ambient Temp	operating : 0~40[°C] / storage : -20~60[°C]						
	Ambient Humidity	20~80[%] RH[avoid dew-condensation]						
	Atmosphere	Avoid direct sunlight, No corrosive gas, Inflammable gas, Oil mist, or Dust						

* In case of allowable load inertia ratio, please apply within 30 times of rotator inertia

Speed-Torque Characteristics

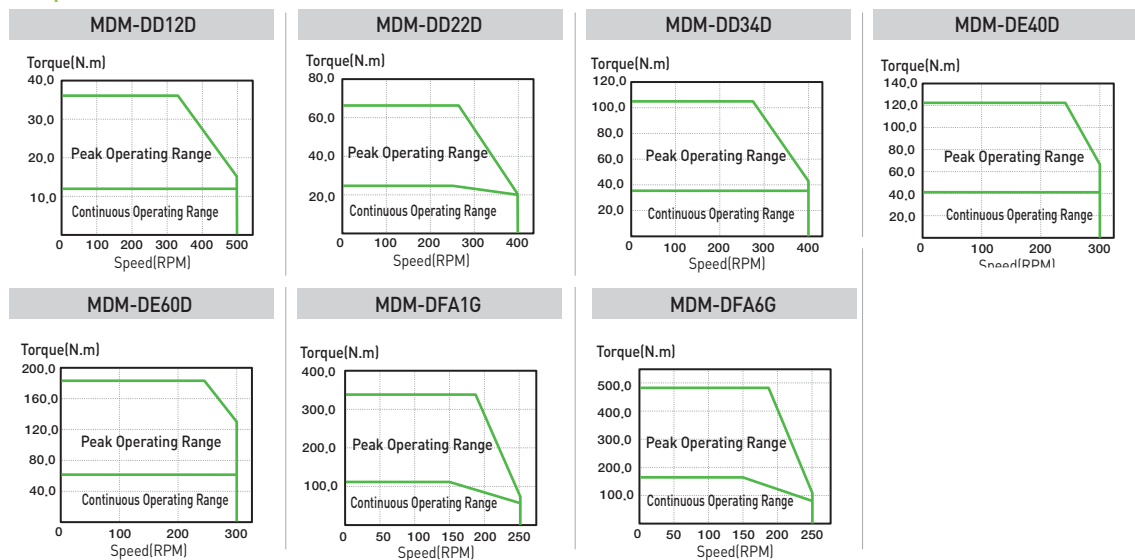

MDM-DB03D, MDM-DB06D, MDM-DB09D

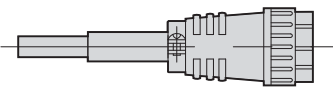

NJC-24-4-PM

Signal	Line color	Pin No.
LEAD U	Red	A
WIRE V	White	B
W	Black	C
FG	Green	D

POWER CONNECTOR

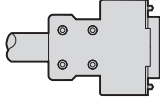

D.D SERVO ENCODER CABLE			
NO	Encoder Signal	NO	Encoder Signal
1	MA	9	+5V
2	SLO	10	-
3	-	11	-
4	OV	12	-
5	SHIELD	13	-
6	MA	14	-
7	SLO	15	-
8	-	-	-

ENCODER CONNECTOR

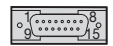

D-Sub Connector (15pin)

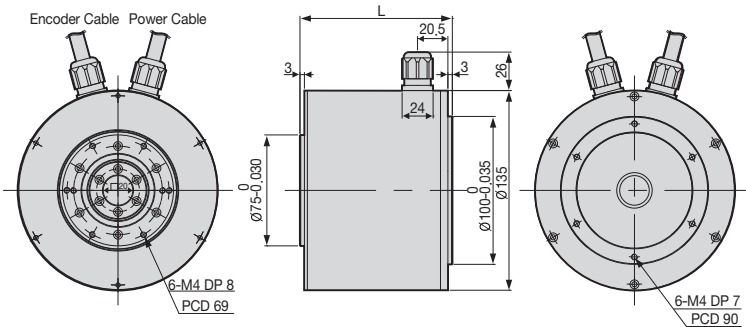

Encoder Cable Power Cable

6-M4 DP 8 PCD 69

6-M4 DP 7 PCD 90

Model Series	External Dimensions(mm)		Weight(kg)
	L		
MDM-DB03D	78		6.3
MDM-DB06D	100		7.2
MDM-DB09D	124		9.2

MDM-DC06D, MDM-DC12D, MDM-DC18D

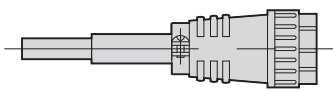

NJC-24-4-PM

Signal	Line color	Pin No.
LEAD U	Red	A
WIRE V	White	B
W	Black	C
FG	Green	D

POWER CONNECTOR

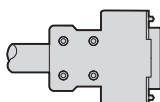

D.D SERVO ENCODER CABLE			
NO	Encoder Signal	NO	Encoder Signal
1	MA	9	+5V
2	SLO	10	-
3	-	11	-
4	OV	12	-
5	SHIELD	13	-
6	MA	14	-
7	SLO	15	-
8	-	-	-

ENCODER CONNECTOR

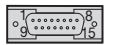

D-Sub Connector (15pin)

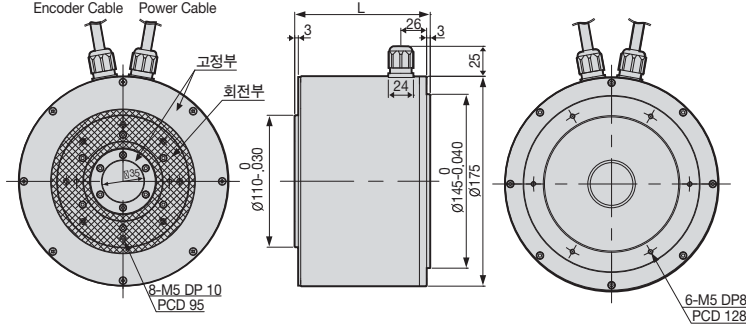

Encoder Cable Power Cable

고정부 회전부

8-M5 DP 10 PCD 95

6-M5 DP 8 PCD 128

Model Series	External Dimensions(mm)		Weight(kg)
	L		
MDM-DC06D	77		8.7
MDM-DC12D	95		10.6
MDM-DC18D	113		12.6

MDM-DD12D, MDM-DD22D, MDM-DD34D

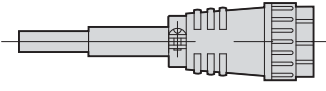

NJC-24-4-PM

Signal	Line color	Pin No.
U	Red	A
V	White	B
W	Black	C
FG	Green	D

POWER CONNECTOR

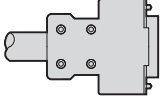

D- Sub Connector (15pin)

D.D SERVO ENCODER CABLE			
NO	Encoder Signal	NO	Encoder Signal
1	MA	9	+5V
2	SLO	10	-
3	-	11	-
4	OV	12	-
5	SHIELD	13	-
6	MA	14	-
7	SLO	15	-
8	-	-	-

ENCODER CONNECTOR

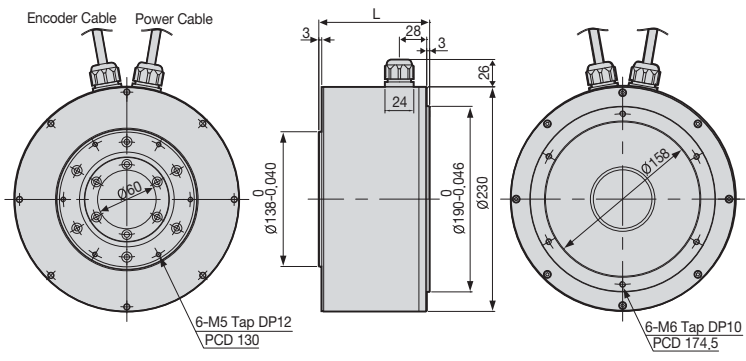

Encoder Cable Power Cable

6-M5 Tap DP12 PCD 130

6-M6 Tap DP10 PCD 174.5

Model Series	External Dimensions(mm)		Weight(kg)
	L		
MDM-DD12D	82.5		17.3
MDM-DD22D	100.5		19.6
MDM-DD34D	118.5		21.9

MDM-DE40D, MDM-DE60D

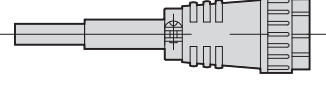

NJC-24-4-PM

내용	Line color	Pin No.
U	Red	A
V	White	B
W	Black	C
FG	Green	D

POWER CONNECTOR

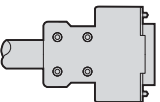

D- Sub Connector (15pin)

D.D SERVO ENCODER CABLE			
NO	Encoder Signal	NO	Encoder Signal
1	MA	9	+5V
2	SLO	10	-
3	-	11	-
4	OV	12	-
5	SHIELD	13	-
6	MA	14	-
7	SLO	15	-
8	-	-	-

ENCODER CONNECTOR

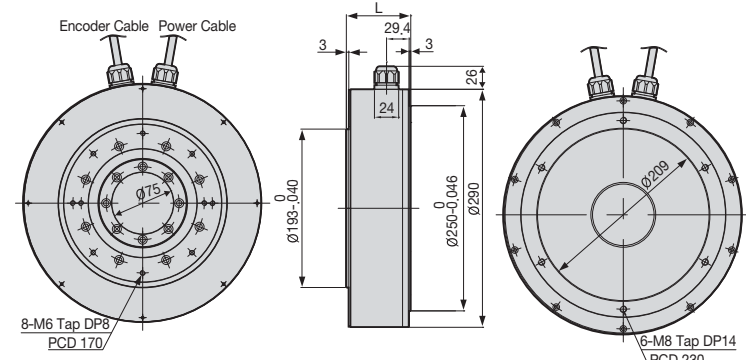

Encoder Cable Power Cable

8-M6 Tap DP8 PCD 170

6-M6 Tap DP14 PCD 230

Model Series	External Dimensions(mm)		Weight(kg)
	L		
MDM-DE40D	95.4		28.2
MDM-DE60D	113.4		35

MDM-DFA1G, MDM-DFA6G

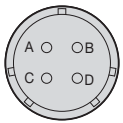

제작사: Nanaboshi Electronic
NJC-24-4-PM

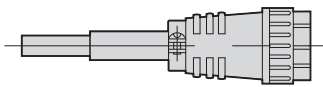

Signal	Line color	Pin No.
LEAD WIRE	U Red	A
	V White	B
	W Black	C
	FG Green	D

POWER CONNECTOR

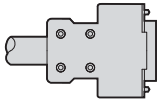

D- Sub Connector (15pin)

D.D SERVO ENCODER CABLE			
NO	Encoder Signal	NO	Encoder Signal
1	MA	9	+5V
2	SLO	10	-
3	-	11	-
4	OV	12	-
5	SHIELD	13	-
6	MA	14	-
7	SLO	15	-
8	-		

ENCODER CONNECTOR

Encoder Cable Power Cable

6-M8 Tap DP16 PCD 232

6-M8 DP 7 PCD 300

80° 돌기각

Model Series	External Dimensions(mm)		Weight(kg)
	L		
MDM-DFA1G	131		54
MDM-DFA6G	167		70.3



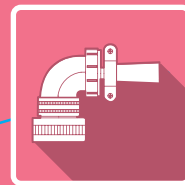

Options and Accessories

Contents

Signal cable	102
Power cable	106
DD Motor Signal cable	113
Other options [Signal cable]	114
Other options [Connector]	115
200V Braking Resistor	116
400V Braking Resistor	117

Signal Cable [Incremental]

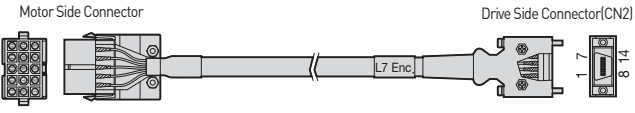
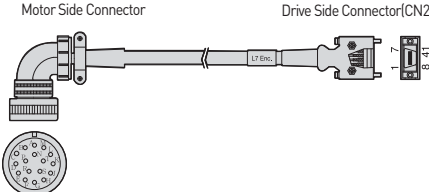
Type	Product Type	Model Name ^[Note1]	Applicable Drive	Applicable Motor	Specifications																																																																								
For Signal	Parallel Encoder Cable (Small Capacity)	XLCS-E□□□AS	XDL-L7SA□□□A L7NHA□□□U L7PA□□□U	All Models of XML-SA SB SC HB SERIES	 <table border="1" data-bbox="869 600 1332 824"> <thead> <tr> <th>PIN No.</th> <th>Encoder Signal</th> <th>PIN No.</th> <th>Encoder Signal</th> <th>PIN No.</th> <th>Encoder Signal</th> <th>PIN No.</th> <th>Encoder Signal</th> </tr> </thead> <tbody> <tr><td>1</td><td>A</td><td>9</td><td>V</td><td>1</td><td>W</td><td>8</td><td>Z̄</td></tr> <tr><td>2</td><td>Ā</td><td>10</td><td>V̄</td><td>2</td><td>W̄</td><td>9</td><td>Z</td></tr> <tr><td>3</td><td>B</td><td>11</td><td>W</td><td>3</td><td>V</td><td>10</td><td>B̄</td></tr> <tr><td>4</td><td>B̄</td><td>12</td><td>W̄</td><td>4</td><td>V̄</td><td>11</td><td>B</td></tr> <tr><td>5</td><td>Z</td><td>13</td><td>+5V</td><td>5</td><td>U</td><td>12</td><td>Ā</td></tr> <tr><td>6</td><td>Z̄</td><td>14</td><td>OV</td><td>6</td><td>Ū</td><td>13</td><td>A</td></tr> <tr><td>7</td><td>U</td><td>15</td><td>SHIELD</td><td>7</td><td>OV</td><td>14</td><td>+5V</td></tr> <tr><td>8</td><td>Ū</td><td></td><td></td><td></td><td>PLATE</td><td></td><td>SHIELD</td></tr> </tbody> </table> <p data-bbox="869 824 981 846">[Motor Side Connector]</p> <p data-bbox="1101 824 1212 846">[Driver Side Connector]</p> <ol style="list-style-type: none"> Motor Side Connector <ul style="list-style-type: none"> Cap Spec.(15 Position) : 172163-1(AMP) Socket Spec. : 170361-1(AMP) Driver Side Connector(CN2) <ul style="list-style-type: none"> Case Spec. : 10314-52A0-008(3M) or SM-14J(Suntone) Connector Spec. : 10114-3000VE(3M) or SM-14J(Suntone) Cable Spec. : 7P×0.25Q or 7P×AWG24 	PIN No.	Encoder Signal	PIN No.	Encoder Signal	PIN No.	Encoder Signal	PIN No.	Encoder Signal	1	A	9	V	1	W	8	Z̄	2	Ā	10	V̄	2	W̄	9	Z	3	B	11	W	3	V	10	B̄	4	B̄	12	W̄	4	V̄	11	B	5	Z	13	+5V	5	U	12	Ā	6	Z̄	14	OV	6	Ū	13	A	7	U	15	SHIELD	7	OV	14	+5V	8	Ū				PLATE		SHIELD
					PIN No.	Encoder Signal	PIN No.	Encoder Signal	PIN No.	Encoder Signal	PIN No.	Encoder Signal																																																																	
1	A	9	V	1	W	8	Z̄																																																																						
2	Ā	10	V̄	2	W̄	9	Z																																																																						
3	B	11	W	3	V	10	B̄																																																																						
4	B̄	12	W̄	4	V̄	11	B																																																																						
5	Z	13	+5V	5	U	12	Ā																																																																						
6	Z̄	14	OV	6	Ū	13	A																																																																						
7	U	15	SHIELD	7	OV	14	+5V																																																																						
8	Ū				PLATE		SHIELD																																																																						
For Signal	Parallel Encoder Cable (Middle Capacity)	XLCS-E□□□BS	XDL-L7SA□□□A L7NHA□□□U L7PA□□□U	All Models of XML-SE/SEP SF/SFP SG/SGP LF LG HE SERIES	 <table border="1" data-bbox="861 1384 1324 1608"> <thead> <tr> <th>PIN No.</th> <th>Encoder Signal</th> <th>PIN No.</th> <th>Encoder Signal</th> <th>PIN No.</th> <th>Encoder Signal</th> <th>PIN No.</th> <th>Encoder Signal</th> </tr> </thead> <tbody> <tr><td>A</td><td>A</td><td>M</td><td>V</td><td>1</td><td>W</td><td>8</td><td>Z̄</td></tr> <tr><td>B</td><td>Ā</td><td>N</td><td>V̄</td><td>2</td><td>W̄</td><td>9</td><td>Z</td></tr> <tr><td>C</td><td>B</td><td>P</td><td>W</td><td>3</td><td>V</td><td>10</td><td>B̄</td></tr> <tr><td>D</td><td>B̄</td><td>R</td><td>W̄</td><td>4</td><td>V̄</td><td>11</td><td>B</td></tr> <tr><td>E</td><td>Z</td><td>H</td><td>+5V</td><td>5</td><td>U</td><td>12</td><td>Ā</td></tr> <tr><td>F</td><td>Z̄</td><td>G</td><td>OV</td><td>6</td><td>Ū</td><td>13</td><td>A</td></tr> <tr><td>K</td><td>U</td><td>J</td><td>SHIELD</td><td>7</td><td>OV</td><td>14</td><td>+5V</td></tr> <tr><td>L</td><td>Ū</td><td></td><td></td><td></td><td>PLATE</td><td></td><td>SHIELD</td></tr> </tbody> </table> <p data-bbox="861 1608 973 1630">[Motor Side Connector]</p> <p data-bbox="1093 1608 1204 1630">[Driver Side Connector]</p> <ol style="list-style-type: none"> Motor Side Connector(MS : Military Standard) <ul style="list-style-type: none"> Plug Spec. : MS3108B20-29S Driver Side Connector(CN2) <ul style="list-style-type: none"> Case Spec. : 10314-52A0-008(3M) or SM-14J(Suntone) Connector Spec. : 10114-3000VE(3M) or SM-14J(Suntone) Cable Spec. : 7P×0.25Q or 7P×AWG24 	PIN No.	Encoder Signal	PIN No.	Encoder Signal	PIN No.	Encoder Signal	PIN No.	Encoder Signal	A	A	M	V	1	W	8	Z̄	B	Ā	N	V̄	2	W̄	9	Z	C	B	P	W	3	V	10	B̄	D	B̄	R	W̄	4	V̄	11	B	E	Z	H	+5V	5	U	12	Ā	F	Z̄	G	OV	6	Ū	13	A	K	U	J	SHIELD	7	OV	14	+5V	L	Ū				PLATE		SHIELD
PIN No.	Encoder Signal	PIN No.	Encoder Signal	PIN No.	Encoder Signal	PIN No.	Encoder Signal																																																																						
A	A	M	V	1	W	8	Z̄																																																																						
B	Ā	N	V̄	2	W̄	9	Z																																																																						
C	B	P	W	3	V	10	B̄																																																																						
D	B̄	R	W̄	4	V̄	11	B																																																																						
E	Z	H	+5V	5	U	12	Ā																																																																						
F	Z̄	G	OV	6	Ū	13	A																																																																						
K	U	J	SHIELD	7	OV	14	+5V																																																																						
L	Ū				PLATE		SHIELD																																																																						

[Note1] □ □ □ of Model Name indicates the kind and length of cable. And the declaration is as below.

Cable Length(m)	3	5	10	20
General Cable(N)	N03	N05	N10	N20
Robotic Cable(F)	F03	F05	F10	F20

Signal Cable [Serial]

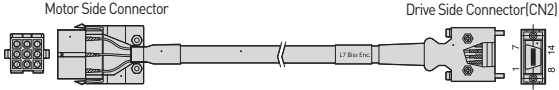
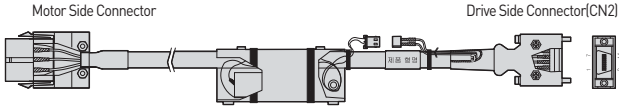
Type	Product Type	Model Name ^[Note1]	Applicable Drive	Applicable Motor	Specifications																																																																		
For Signal	S Series Motor S-turn Encoder Cable (Small Capacity)	XLCS-E□□□CS	XDL-L7S□□□B L7NA□□□B L7NH□□□□U L7PA□□□U	All Models of XML-SA SB SC SERIES	 <table border="1" data-bbox="1050 611 1436 869"> <thead> <tr> <th>PIN No.</th> <th>Encoder Signal</th> <th>PIN No.</th> <th>Encoder Signal</th> <th>PIN No.</th> <th>Encoder Signal</th> </tr> </thead> <tbody> <tr> <td>1</td> <td>MA</td> <td>1</td> <td>-</td> <td>8</td> <td>-</td> </tr> <tr> <td>2</td> <td>MA</td> <td>2</td> <td>-</td> <td>9</td> <td>-</td> </tr> <tr> <td>3</td> <td>SLO</td> <td>3</td> <td>MA</td> <td>10</td> <td>-</td> </tr> <tr> <td>4</td> <td>SLO</td> <td>4</td> <td>MA</td> <td>11</td> <td>-</td> </tr> <tr> <td>5</td> <td>-</td> <td>5</td> <td>SLO</td> <td>12</td> <td>-</td> </tr> <tr> <td>6</td> <td>-</td> <td>6</td> <td>SLO</td> <td>13</td> <td>-</td> </tr> <tr> <td>7</td> <td>+5V</td> <td>7</td> <td>OV</td> <td>14</td> <td>+5V</td> </tr> <tr> <td>8</td> <td>OV</td> <td colspan="2">PLATE</td> <td colspan="2">SHIELD</td> </tr> <tr> <td>9</td> <td>SHIELD</td> <td colspan="2">[Driver Side Connector]</td> <td colspan="2"></td> </tr> </tbody> </table> <p data-bbox="1050 857 1157 875">[Motor Side Connector]</p> <p data-bbox="1204 835 1316 853">[Driver Side Connector]</p> <ol style="list-style-type: none"> Motor Side Connector <ul style="list-style-type: none"> Cap Spec.(9 Position) : 172161-1(AMP) Socket Spec. : 170361-1(AMP) Drive Side Connector(CN2) <ul style="list-style-type: none"> Case Spec. : 10314-52A0-008(3M)or SM-14J(Suntone) Connector Spec. : 10114-3000VE(3M)or SM-14J(Suntone) Cable Spec. : 3P×0.25Q or 3P×24AWG 	PIN No.	Encoder Signal	PIN No.	Encoder Signal	PIN No.	Encoder Signal	1	MA	1	-	8	-	2	MA	2	-	9	-	3	SLO	3	MA	10	-	4	SLO	4	MA	11	-	5	-	5	SLO	12	-	6	-	6	SLO	13	-	7	+5V	7	OV	14	+5V	8	OV	PLATE		SHIELD		9	SHIELD	[Driver Side Connector]									
					PIN No.	Encoder Signal	PIN No.	Encoder Signal	PIN No.	Encoder Signal																																																													
1	MA	1	-	8	-																																																																		
2	MA	2	-	9	-																																																																		
3	SLO	3	MA	10	-																																																																		
4	SLO	4	MA	11	-																																																																		
5	-	5	SLO	12	-																																																																		
6	-	6	SLO	13	-																																																																		
7	+5V	7	OV	14	+5V																																																																		
8	OV	PLATE		SHIELD																																																																			
9	SHIELD	[Driver Side Connector]																																																																					
For Signal	S Series Motor M-turn Encoder Cable (Small Capacity)	XLCS-E□□□CS1	XDL-L7S□□□B L7NA□□□B L7NH□□□□U L7PA□□□U	All Models of XML-SA SB SC SERIES	 <table border="1" data-bbox="842 1323 981 1570"> <thead> <tr> <th>PIN No.</th> <th>Encoder Signal</th> <th>PIN No.</th> <th>Encoder Signal</th> <th>PIN No.</th> <th>Encoder Signal</th> </tr> </thead> <tbody> <tr> <td>1</td> <td>MA</td> <td>1</td> <td>-</td> <td>8</td> <td>-</td> </tr> <tr> <td>2</td> <td>MA</td> <td>2</td> <td>-</td> <td>9</td> <td>-</td> </tr> <tr> <td>3</td> <td>SL</td> <td>3</td> <td>MA</td> <td>10</td> <td>-</td> </tr> <tr> <td>4</td> <td>SL</td> <td>4</td> <td>MA</td> <td>11</td> <td>-</td> </tr> <tr> <td>5</td> <td>VOD_B</td> <td>5</td> <td>SLO</td> <td>12</td> <td>-</td> </tr> <tr> <td>6</td> <td>GND_B</td> <td>6</td> <td>SLO</td> <td>13</td> <td>-</td> </tr> <tr> <td>7</td> <td>+5V</td> <td>7</td> <td>OV</td> <td>14</td> <td>+5V</td> </tr> <tr> <td>8</td> <td>OV</td> <td colspan="2">PLATE</td> <td colspan="2">SHIELD</td> </tr> <tr> <td>9</td> <td>SHIELD</td> <td colspan="2">[Driver Side Connector]</td> <td colspan="2"></td> </tr> </tbody> </table> <p data-bbox="774 1368 829 1400">AMP 12290 CAP 30C1940B</p> <table border="1" data-bbox="1300 1377 1444 1478"> <thead> <tr> <th>PIN No.</th> <th>Encoder Signal</th> </tr> </thead> <tbody> <tr> <td>1</td> <td>BATTERY(VDD_B)</td> </tr> <tr> <td>2</td> <td>BATTERY OV(GND_B)</td> </tr> </tbody> </table> <p data-bbox="1300 1467 1396 1485">[Battery Connector]</p> <ol style="list-style-type: none"> Motor Side Connector <ul style="list-style-type: none"> CAP Spec.(9 Position) : 172161-1(AMP) Socket Spec. : 170361-1(AMP) Drive Side Connector(CN2) <ul style="list-style-type: none"> Case Spec. : 10314-52A0-008(3M) or SM-14J(Suntone) Connector Spec. : 10114-3000VE(3M) or SM-14J(Suntone) Cable Spec. : 4P×0.25Q or 4P×24AWG Cable Spec. : 3P×0.25Q or 3P×24AWG 	PIN No.	Encoder Signal	PIN No.	Encoder Signal	PIN No.	Encoder Signal	1	MA	1	-	8	-	2	MA	2	-	9	-	3	SL	3	MA	10	-	4	SL	4	MA	11	-	5	VOD_B	5	SLO	12	-	6	GND_B	6	SLO	13	-	7	+5V	7	OV	14	+5V	8	OV	PLATE		SHIELD		9	SHIELD	[Driver Side Connector]				PIN No.	Encoder Signal	1	BATTERY(VDD_B)	2	BATTERY OV(GND_B)
PIN No.	Encoder Signal	PIN No.	Encoder Signal	PIN No.	Encoder Signal																																																																		
1	MA	1	-	8	-																																																																		
2	MA	2	-	9	-																																																																		
3	SL	3	MA	10	-																																																																		
4	SL	4	MA	11	-																																																																		
5	VOD_B	5	SLO	12	-																																																																		
6	GND_B	6	SLO	13	-																																																																		
7	+5V	7	OV	14	+5V																																																																		
8	OV	PLATE		SHIELD																																																																			
9	SHIELD	[Driver Side Connector]																																																																					
PIN No.	Encoder Signal																																																																						
1	BATTERY(VDD_B)																																																																						
2	BATTERY OV(GND_B)																																																																						

[Note1] □□□ of Model Name indicates the kind and length of cable. And the declaration is as below.

Cable Length(m)	3	5	10	20
General Cable(N)	N03	N05	N10	N20
Robotic Cable(F)	F03	F05	F10	F20

Signal Cable [Serial]

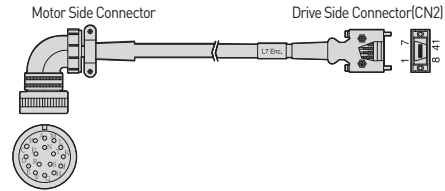
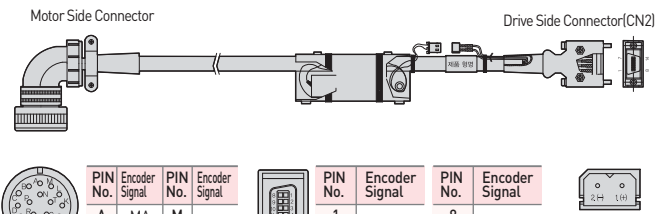
Type	Product Type	Model Name ^[Note1]	Applicable Drive	Applicable Motor	Specifications																																																																								
For Signal	S/F Series Motor S-turn Encoder Cable (Middle Capacity)	XLCS-E□□□DS	XDL-L7S□□□B L7NA□□□B L7NH□□□□U L7PA□□□U	All Models of XML-SE FE/SEP/FEP SF/FF SFP/FFP SG/FG SGP/FGP LF LG SERIES	 <table border="1" data-bbox="901 672 1364 896"> <thead> <tr> <th>PIN No.</th> <th>Encoder Signal</th> <th>PIN No.</th> <th>Encoder Signal</th> <th>PIN No.</th> <th>Encoder Signal</th> <th>PIN No.</th> <th>Encoder Signal</th> </tr> </thead> <tbody> <tr> <td>A</td> <td>MA</td> <td>M</td> <td>-</td> <td>1</td> <td>-</td> <td>8</td> <td>-</td> </tr> <tr> <td>B</td> <td>MA</td> <td>N</td> <td>-</td> <td>2</td> <td>-</td> <td>9</td> <td>-</td> </tr> <tr> <td>C</td> <td>SLO</td> <td>P</td> <td>-</td> <td>3</td> <td>MA</td> <td>10</td> <td>-</td> </tr> <tr> <td>D</td> <td>SLO</td> <td>R</td> <td>-</td> <td>4</td> <td>MA</td> <td>11</td> <td>-</td> </tr> <tr> <td>E</td> <td>-</td> <td>H</td> <td>+5V</td> <td>5</td> <td>SLO</td> <td>12</td> <td>-</td> </tr> <tr> <td>F</td> <td>-</td> <td>G</td> <td>OV</td> <td>6</td> <td>SLO</td> <td>13</td> <td>-</td> </tr> <tr> <td>K</td> <td>-</td> <td>J</td> <td>SHIELD</td> <td>7</td> <td>OV</td> <td>14</td> <td>+5V</td> </tr> <tr> <td>L</td> <td>-</td> <td>-</td> <td>-</td> <td colspan="2">PLATE</td> <td colspan="2">SHIELD</td> </tr> </tbody> </table> <p>(Motor Side Connector) (Drive Side Connector)</p> <ol style="list-style-type: none"> Motor Side Connector(MS : Military Standard) <ul style="list-style-type: none"> Plug Spec. : MS3108B20-29S Drive Side Connector(CN2) <ul style="list-style-type: none"> Case Spec. : 10314-52A0-008(3M) or SM-14J(Suntone) Connector Spec. : 10114-3000VE(3M) or SM-14J(Suntone) Cable Spec. : 3P×0.25Q or 3P×24AWG 	PIN No.	Encoder Signal	PIN No.	Encoder Signal	PIN No.	Encoder Signal	PIN No.	Encoder Signal	A	MA	M	-	1	-	8	-	B	MA	N	-	2	-	9	-	C	SLO	P	-	3	MA	10	-	D	SLO	R	-	4	MA	11	-	E	-	H	+5V	5	SLO	12	-	F	-	G	OV	6	SLO	13	-	K	-	J	SHIELD	7	OV	14	+5V	L	-	-	-	PLATE		SHIELD	
					PIN No.	Encoder Signal	PIN No.	Encoder Signal	PIN No.	Encoder Signal	PIN No.	Encoder Signal																																																																	
A	MA	M	-	1	-	8	-																																																																						
B	MA	N	-	2	-	9	-																																																																						
C	SLO	P	-	3	MA	10	-																																																																						
D	SLO	R	-	4	MA	11	-																																																																						
E	-	H	+5V	5	SLO	12	-																																																																						
F	-	G	OV	6	SLO	13	-																																																																						
K	-	J	SHIELD	7	OV	14	+5V																																																																						
L	-	-	-	PLATE		SHIELD																																																																							
For Signal	S/F Series Motor M-turn Encoder Cable (Middle Capacity)	XLCS-E□□□DS1	XDL-L7S□□□B L7NA□□□B L7NH□□□□U L7PA□□□U	All Models of XML-SE/FE SEP/FEP SF/FF SFP/FFP SG/FG SGP/FGP LF LG SERIES	 <table border="1" data-bbox="774 1355 1436 1590"> <thead> <tr> <th>PIN No.</th> <th>Encoder Signal</th> <th>PIN No.</th> <th>Encoder Signal</th> <th>PIN No.</th> <th>Encoder Signal</th> <th>PIN No.</th> <th>Encoder Signal</th> </tr> </thead> <tbody> <tr> <td>A</td> <td>MA</td> <td>M</td> <td>-</td> <td>1</td> <td>-</td> <td>8</td> <td>-</td> </tr> <tr> <td>B</td> <td>MA</td> <td>N</td> <td>-</td> <td>2</td> <td>-</td> <td>9</td> <td>-</td> </tr> <tr> <td>C</td> <td>SLO</td> <td>P</td> <td>-</td> <td>3</td> <td>MA</td> <td>10</td> <td>-</td> </tr> <tr> <td>D</td> <td>SLO</td> <td>R</td> <td>-</td> <td>4</td> <td>MA</td> <td>11</td> <td>-</td> </tr> <tr> <td>E</td> <td>VDD_B</td> <td>H</td> <td>+5V</td> <td>5</td> <td>SLO</td> <td>12</td> <td>-</td> </tr> <tr> <td>F</td> <td>GND_B</td> <td>G</td> <td>OV</td> <td>6</td> <td>SLO</td> <td>13</td> <td>-</td> </tr> <tr> <td>G</td> <td>-</td> <td>J</td> <td>SHIELD</td> <td>7</td> <td>OV</td> <td>14</td> <td>+5V</td> </tr> <tr> <td>L</td> <td>-</td> <td>-</td> <td>-</td> <td colspan="2">PLATE</td> <td colspan="2">SHIELD</td> </tr> </tbody> </table> <p>(Motor Side Connector) (Drive Side Connector)</p> <ol style="list-style-type: none"> Motor Side Connector(MS : Military Standard) <ul style="list-style-type: none"> Plug Spec. : MS3108B20-29S Drive Side Connector(CN2) <ul style="list-style-type: none"> Case Spec. : 10314-52A0-008(3M) or SM-14J(Suntone) Connector Spec. : 10114-3000VE(3M) or SM-14J(Suntone) Cable Spec. : 4P×0.25Q or 4P×24AWG Battery Connector Spec. : 5267-02A(MOLEX) 	PIN No.	Encoder Signal	PIN No.	Encoder Signal	PIN No.	Encoder Signal	PIN No.	Encoder Signal	A	MA	M	-	1	-	8	-	B	MA	N	-	2	-	9	-	C	SLO	P	-	3	MA	10	-	D	SLO	R	-	4	MA	11	-	E	VDD_B	H	+5V	5	SLO	12	-	F	GND_B	G	OV	6	SLO	13	-	G	-	J	SHIELD	7	OV	14	+5V	L	-	-	-	PLATE		SHIELD	
PIN No.	Encoder Signal	PIN No.	Encoder Signal	PIN No.	Encoder Signal	PIN No.	Encoder Signal																																																																						
A	MA	M	-	1	-	8	-																																																																						
B	MA	N	-	2	-	9	-																																																																						
C	SLO	P	-	3	MA	10	-																																																																						
D	SLO	R	-	4	MA	11	-																																																																						
E	VDD_B	H	+5V	5	SLO	12	-																																																																						
F	GND_B	G	OV	6	SLO	13	-																																																																						
G	-	J	SHIELD	7	OV	14	+5V																																																																						
L	-	-	-	PLATE		SHIELD																																																																							

[Note1] □□□ of Model Name indicates the kind and length of cable. And the declaration is as below.

Cable Length(m)	3	5	10	20
General Cable(N)	N03	N05	N10	N20
Robotic Cable(F)	F03	F05	F10	F20

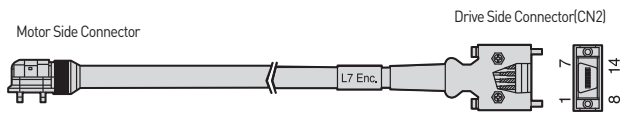
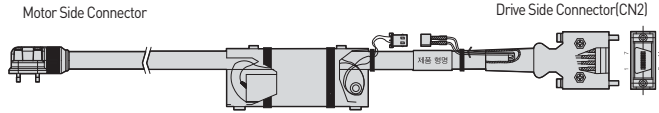
Type	Product Type	Model Name ^(Note1)	Applicable Drive	Applicable Motor	Specifications																																																												
For Signal	F Series Motor S-turn Encoder Cable (Small Capacity)	XLCS-E□□□ES-□	XDL-L7S□□□B L7NA□□□B L7NH□□□□U L7PA□□□U	All Models of XML-FAL FB/FBL FC/FCL SERIES	 <p>Motor Side Connector</p> <p>Drive Side Connector(CN2)</p> <table border="1"> <thead> <tr> <th>PIN No.</th> <th>Encoder Signal</th> <th>PIN No.</th> <th>Encoder Signal</th> <th>PIN No.</th> <th>Encoder Signal</th> </tr> </thead> <tbody> <tr> <td>1</td> <td>MA</td> <td>1</td> <td>-</td> <td>8</td> <td>-</td> </tr> <tr> <td>2</td> <td>SLO</td> <td>2</td> <td>-</td> <td>9</td> <td>-</td> </tr> <tr> <td>3</td> <td>-</td> <td>3</td> <td>MA</td> <td>10</td> <td>-</td> </tr> <tr> <td>4</td> <td>OV</td> <td>4</td> <td>MA</td> <td>11</td> <td>-</td> </tr> <tr> <td>5</td> <td>SHIELD</td> <td>5</td> <td>SLO</td> <td>12</td> <td>-</td> </tr> <tr> <td>6</td> <td>MA</td> <td>6</td> <td>SLO</td> <td>13</td> <td>-</td> </tr> <tr> <td>7</td> <td>SLO</td> <td>7</td> <td>OV</td> <td>14</td> <td>+5V</td> </tr> <tr> <td>8</td> <td>-</td> <td colspan="2">PLATE</td> <td colspan="2">SHIELD</td> </tr> <tr> <td>9</td> <td>+5V</td> <td colspan="4"></td> </tr> </tbody> </table> <p>(Motor Side Connector)</p> <p>(Drive Side Connector)</p> <p>Tyco Connector (7Circuits)</p> <p>1. Motor Side Connector</p> <ul style="list-style-type: none"> • Cap Spec. : 2201825-1(Tyco) • Socket Spec. : 2174065-4(Tyco) <p>2. Drive Side Connector(CN2)</p> <ul style="list-style-type: none"> • Case Spec. : 10314-52A0-008(3M) or SM-14J(Suntone) • Connector Spec. : 10114-3000VE(3M) or SM-14J(Suntone) <p>3. Cable Spec. : 3P×0.25Q or 3P×24AWG</p>	PIN No.	Encoder Signal	PIN No.	Encoder Signal	PIN No.	Encoder Signal	1	MA	1	-	8	-	2	SLO	2	-	9	-	3	-	3	MA	10	-	4	OV	4	MA	11	-	5	SHIELD	5	SLO	12	-	6	MA	6	SLO	13	-	7	SLO	7	OV	14	+5V	8	-	PLATE		SHIELD		9	+5V				
					PIN No.	Encoder Signal	PIN No.	Encoder Signal	PIN No.	Encoder Signal																																																							
1	MA	1	-	8	-																																																												
2	SLO	2	-	9	-																																																												
3	-	3	MA	10	-																																																												
4	OV	4	MA	11	-																																																												
5	SHIELD	5	SLO	12	-																																																												
6	MA	6	SLO	13	-																																																												
7	SLO	7	OV	14	+5V																																																												
8	-	PLATE		SHIELD																																																													
9	+5V																																																																
For Signal	F Series Motor M-turn Encoder Cable (Small Capacity)	XLCS-E□□□ES1-□	XDL-L7S□□□B L7NA□□□B L7NH□□□□U L7PA□□□U	All Models of XML-FAL FB/FBL FC/FCL SERIES	 <p>Motor Side Connector</p> <p>Drive Side Connector(CN2)</p> <table border="1"> <thead> <tr> <th>PIN No.</th> <th>Encoder Signal</th> <th>PIN No.</th> <th>Encoder Signal</th> <th>PIN No.</th> <th>Encoder Signal</th> </tr> </thead> <tbody> <tr> <td>1</td> <td>MA</td> <td>1</td> <td>-</td> <td>8</td> <td>-</td> </tr> <tr> <td>2</td> <td>SLO</td> <td>2</td> <td>-</td> <td>9</td> <td>-</td> </tr> <tr> <td>3</td> <td>GND_B</td> <td>3</td> <td>MA</td> <td>10</td> <td>-</td> </tr> <tr> <td>4</td> <td>OV</td> <td>4</td> <td>MA</td> <td>11</td> <td>-</td> </tr> <tr> <td>5</td> <td>SHIELD</td> <td>5</td> <td>SLO</td> <td>12</td> <td>-</td> </tr> <tr> <td>6</td> <td>MA</td> <td>6</td> <td>SLO</td> <td>13</td> <td>-</td> </tr> <tr> <td>7</td> <td>SLO</td> <td>7</td> <td>OV</td> <td>14</td> <td>+5V</td> </tr> <tr> <td>8</td> <td>VOD_B</td> <td colspan="2">PLATE</td> <td colspan="2">SHIELD</td> </tr> <tr> <td>9</td> <td>+5V</td> <td colspan="4"></td> </tr> </tbody> </table> <p>(Motor Side Connector)</p> <p>(Driver Side Connector)</p> <p>(Front Direction)</p> <p>(Rear Direction)</p> <p>1. Motor Side Connector</p> <ul style="list-style-type: none"> • Cap Spec. : 2201825-1(Tyco) • Socket Spec. : 2174065-4(Tyco) <p>2. Drive Side Connector(CN2)</p> <ul style="list-style-type: none"> • Cap Spec. : 10314-52A0-008(3M) or SM-14J(Suntone) • Connector Spec. : 10114-3000VE(3M) or SM-14J(Suntone) <p>3. Cable Spec. : 4P×0.25Q or 4P×24AWG</p> <p>4. Battery Connector Spec. : 5267-02A(MOLEX)</p>	PIN No.	Encoder Signal	PIN No.	Encoder Signal	PIN No.	Encoder Signal	1	MA	1	-	8	-	2	SLO	2	-	9	-	3	GND_B	3	MA	10	-	4	OV	4	MA	11	-	5	SHIELD	5	SLO	12	-	6	MA	6	SLO	13	-	7	SLO	7	OV	14	+5V	8	VOD_B	PLATE		SHIELD		9	+5V				
					PIN No.	Encoder Signal	PIN No.	Encoder Signal	PIN No.	Encoder Signal																																																							
1	MA	1	-	8	-																																																												
2	SLO	2	-	9	-																																																												
3	GND_B	3	MA	10	-																																																												
4	OV	4	MA	11	-																																																												
5	SHIELD	5	SLO	12	-																																																												
6	MA	6	SLO	13	-																																																												
7	SLO	7	OV	14	+5V																																																												
8	VOD_B	PLATE		SHIELD																																																													
9	+5V																																																																

Note1) □□□ of Model Name indicates the kind and length of cable. And the declaration is as below.

Note2) In case of □ marked product, the connector can draw in a direction of Front(load) / Rear(half load). [Front Type : No mark, Rear Type : -R]

Cable Length(m)	3	5	10	20
General Cable(N)	N03	N05	N10	N20
Robotic Cable(F)	F03	F05	F10	F20

Power Cable [200V]

Type	Product Type	Model Name ^(Note1)	Applicable Drive	Applicable Motor	Specifications										
For Power	S Series Power Cable (Small Capacity)	XLCS-P □□□ GS	XDL-L7SA□□□A L7NHA□□□U L7PA□□□U	All Models of XML-SA SB SC HB SERIES	<table border="1"> <thead> <tr> <th>PIN No.</th> <th>Signal</th> </tr> </thead> <tbody> <tr> <td>1</td> <td>U</td> </tr> <tr> <td>2</td> <td>V</td> </tr> <tr> <td>3</td> <td>W</td> </tr> <tr> <td>4</td> <td>Ground</td> </tr> </tbody> </table> <ol style="list-style-type: none"> Motor Side Connector <ul style="list-style-type: none"> Cap Spec.(4 Position) : 172159-1(AMP) Socket Spec. : 170362-1(AMP) Drive Side Connector(U, V, W, FG) <ul style="list-style-type: none"> U, V, W Pin Spec. : 1512 FG Pin Spec. : 1.54x4(Ring Terminal) Cable Spec. : 4C×0.75SQ or 4C×18AWG 	PIN No.	Signal	1	U	2	V	3	W	4	Ground
PIN No.	Signal														
1	U														
2	V														
3	W														
4	Ground														
For Power	S Series Brake Cable (Small Capacity)	XLCS-P □□□ KB	XDL-L7SA□□□A L7NHA□□□U L7PA□□□U	All Models of XML-SA SB SC HB SERIES	<table border="1"> <thead> <tr> <th>PIN No.</th> <th>Signal</th> </tr> </thead> <tbody> <tr> <td>1</td> <td>BK+</td> </tr> <tr> <td>2</td> <td>BK-</td> </tr> </tbody> </table> <ol style="list-style-type: none"> Motor Side Connector <ul style="list-style-type: none"> Cap Spec.(2 Position) : 172157-1(AMP) Socket Spec. : 170362-1(AMP) Drive Side Connector(U, V, W, FG) <ul style="list-style-type: none"> Connecting terminal Spec. : 1.5x3(Ring Terminal) Cable Spec. : 2C×0.75SQ or 2C×18AWG 	PIN No.	Signal	1	BK+	2	BK-				
PIN No.	Signal														
1	BK+														
2	BK-														
For Power	F Series Power Cable (Small Capacity)	XLCS-P □□□ FS-□	XDL-L7SA□□□B L7NA□□□B L7NHA□□□U L7PA□□□U	All Models of XML-FB FC SERIES	<table border="1"> <thead> <tr> <th>PIN No.</th> <th>Signal</th> </tr> </thead> <tbody> <tr> <td>1</td> <td>W</td> </tr> <tr> <td>2</td> <td>V</td> </tr> <tr> <td>3</td> <td>U</td> </tr> <tr> <td>4</td> <td>Ground</td> </tr> </tbody> </table> <ol style="list-style-type: none"> Motor Side Connector <ul style="list-style-type: none"> Plug Spec. : KN5FT04SJ1(JAE) Socket Spec. : ST-KN-S-C1B-3500(JAE) Drive Side Connector(U, V, W, FG) <ul style="list-style-type: none"> U, V, W Pin Spec. : 1512 FG Pin Spec. : 1.5x4(Ring Terminal) Cable Spec. : 4C×0.75SQ or 4C×18AWG 	PIN No.	Signal	1	W	2	V	3	U	4	Ground
PIN No.	Signal														
1	W														
2	V														
3	U														
4	Ground														

Note1) □ □ □ of Model Name indicates the kind and length of cable. And the declaration is as below.

Note2) In case of □ marked product, the connector can draw in a direction of Front(load) / Rear(half load).[Front Type : No mark, Rear Type : -R]

Cable Length(m)	3	5	10	20
General Cable(N)	F03	F05	F10	F20
Robotic Cable(F)	N03	N05	N10	N20

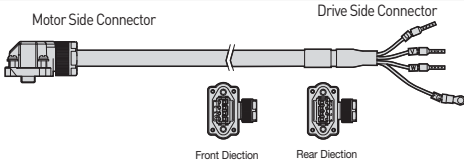
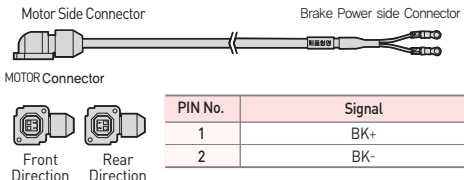
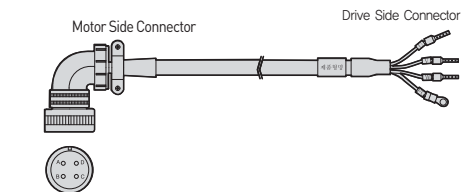
Type	Product Type	Model Name ^{Note1)}	Applicable Drive	Applicable Motor	Specifications										
For Power	L Series Power Cable (Small Capacity)	XLCS-P □□□LS-□	XDL- L7SA□□□B L7NA□□□B L7NHA□□□U L7PA□□□U	All Models of XML- FAL FB/L FCL SERIES	 <table border="1"> <thead> <tr> <th>PIN No.</th> <th>Signal</th> </tr> </thead> <tbody> <tr> <td>A</td> <td>U</td> </tr> <tr> <td>B</td> <td>V</td> </tr> <tr> <td>C</td> <td>W</td> </tr> <tr> <td>D</td> <td>Ground</td> </tr> </tbody> </table> <ol style="list-style-type: none"> Motor Side Connector <ul style="list-style-type: none"> Plug Spec. : SM-JN8FT04(Suntone) Socket Spec. : SMS-201(Suntone) Drive Side Connector (U,V,W,FG) <ul style="list-style-type: none"> U, V, W Pin Spec. : 1512(Ferrule) FG Pin Spec. : 1.5x4 (Ring Terminal) Cable Spec. : 4C×0.75SQ or 4C×18AWG In case of FAL products, Please install Power Cable first before connecting Encoder Cable 	PIN No.	Signal	A	U	B	V	C	W	D	Ground
PIN No.	Signal														
A	U														
B	V														
C	W														
D	Ground														
For Power	Brake Cable for Flat Motor (Small Capacity)	XLCS-B □□□QS-□	XDL- L7SA□□□B L7NA□□□B L7NHA□□□U L7PA□□□U	All Models of XML- FAL FB/FBL FC/FCL SERIES	 <table border="1"> <thead> <tr> <th>PIN No.</th> <th>Signal</th> </tr> </thead> <tbody> <tr> <td>1</td> <td>BK+</td> </tr> <tr> <td>2</td> <td>BK-</td> </tr> </tbody> </table> <ol style="list-style-type: none"> Motor Side Connector <ul style="list-style-type: none"> Plug Spec. : KN5FT02SJ1 Socket Spec. : ST-KN-S-C1B-3500 Drive Side Connector (U,V,W,FG) <ul style="list-style-type: none"> Connecting terminal Spec. : 1.5x3(Ring Terminal) Cable Spec. : 2C×0.75SQ or 2C×18AWG 	PIN No.	Signal	1	BK+	2	BK-				
PIN No.	Signal														
1	BK+														
2	BK-														
For Power	Power Cable (Middle Capacity)	XLCS-P □□□HS	XDL- L7SA□□□A L7SA□□□B L7NA□□□B L7NHA□□□U L7PA□□□U	All Models of XML- SE FE HE SERIES	 <table border="1"> <thead> <tr> <th>PIN No.</th> <th>Signal</th> </tr> </thead> <tbody> <tr> <td>A</td> <td>U</td> </tr> <tr> <td>B</td> <td>V</td> </tr> <tr> <td>C</td> <td>W</td> </tr> <tr> <td>D</td> <td>Ground</td> </tr> </tbody> </table> <ol style="list-style-type: none"> Motor Side Connector <ul style="list-style-type: none"> Plug Spec. : MS3108B20-4S(MS) Drive Side Connector (U,V,W,FG) <ul style="list-style-type: none"> U, V, W Pin Spec. : 2512 FG Pin Spec. : 2.5x4(Ring Terminal) Cable Spec. : 4C×2.5SQ or 4C×14AWG 	PIN No.	Signal	A	U	B	V	C	W	D	Ground
PIN No.	Signal														
A	U														
B	V														
C	W														
D	Ground														

Note1) □ □ □ of Model Name indicates the kind and length of cable. And the declaration is as below.

Note2) In case of □ marked product, the connector can draw in a direction of Front(load) / Rear(half load). [Front Type : No mark, Rear Type : -R]

Cable Length(m)	3	5	10	20
General Cable(N)	F03	F05	F10	F20
Robotic Cable(F)	N03	N05	N10	N20

Power Cable [200V]

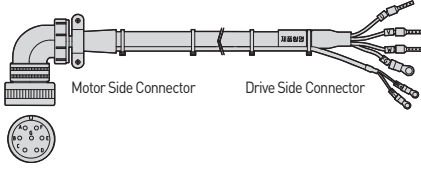
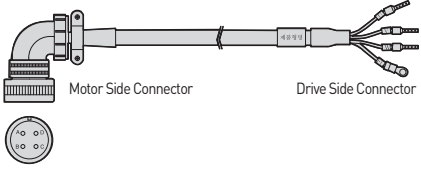
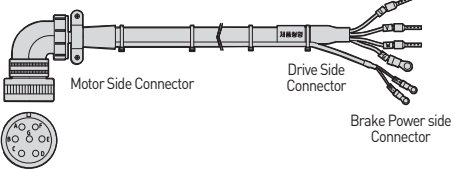
Type	Product Type	Model Name ^{Note1)}	Applicable Drive	Applicable Motor	Specifications																
For Power	Power Cable (Brake Type)	XLCS-P □□□NB	XDL-L7SA□□□A L7SA□□□B L7NA□□□B L7NHA□□□U L7PA□□□U	All Models of XML-SE FE SERIES	 <p>Motor Side Connector Drive Side Connector</p> <table border="1"> <thead> <tr> <th>PIN No.</th> <th>Signal</th> <th>PIN No.</th> <th>Signal</th> </tr> </thead> <tbody> <tr> <td>A</td> <td>U</td> <td>D</td> <td>Ground</td> </tr> <tr> <td>B</td> <td>V</td> <td>E</td> <td>BK+</td> </tr> <tr> <td>C</td> <td>W</td> <td>F</td> <td>BK-</td> </tr> </tbody> </table>	PIN No.	Signal	PIN No.	Signal	A	U	D	Ground	B	V	E	BK+	C	W	F	BK-
					PIN No.	Signal	PIN No.	Signal													
A	U	D	Ground																		
B	V	E	BK+																		
C	W	F	BK-																		
<p>1. Motor Side Connector</p> <ul style="list-style-type: none"> Plug Spec. : MS3108B20-15S(MS) <p>2. Drive Side Connector</p> <ul style="list-style-type: none"> U, V, W Pin Spec. : 2012 Cable Spec. : 4Cx2.5SQ or 4Cx41AWG FG Pin Spec. : 2.5x4(Ring Terminal) <p>3. Brake Power side Connector</p> <ul style="list-style-type: none"> BK Pin Spec. : 1.5x3(Ring Terminal) Cable Spec. : 2Cx07.5SQ or 2Cx18AWG 																					
For Power	Power Cable (Middle Capacity)	XLCS-P □□□IS	XDL-L7SA□□□A L7SA□□□B L7NA□□□B L7NHA□□□U L7PA□□□U	XML-SF30A SF22D/LF35D SF20G/LF30G SF12M/SF20M LF30M/SG22D LG35D/SG20G LG30G/SG12M SG20M/LG30M FF30A/FF22D FF35D/FF20G FF30G/FF12M FF20M/FF30M FG22D/FG35D FG20G/FG30G FG12M/FG20M FG30M	 <p>Motor Side Connector Drive Side Connector</p> <table border="1"> <thead> <tr> <th>PIN No.</th> <th>Signal</th> </tr> </thead> <tbody> <tr> <td>1</td> <td>U</td> </tr> <tr> <td>2</td> <td>V</td> </tr> <tr> <td>3</td> <td>W</td> </tr> <tr> <td>4</td> <td>Ground</td> </tr> </tbody> </table>	PIN No.	Signal	1	U	2	V	3	W	4	Ground						
					PIN No.	Signal															
1	U																				
2	V																				
3	W																				
4	Ground																				
<p>1. Motor Side Connector</p> <ul style="list-style-type: none"> Plug Spec. : MS3108B22-22S(MS) <p>2. Drive Side Connector</p> <ul style="list-style-type: none"> U, V, W Pin Spec. : 2512 FG Pin Spec. : 2.5x4(Ring Terminal) <p>3. Cable Spec. : 4C × 2.5SQ or 4C14AWG</p>																					
For Power	Power Cable (Brake Type)	XLCS-P □□□PB	XDL-L7SA□□□A L7SA□□□B L7NA□□□B L7NHA□□□U L7PA□□□U	XML-SF30A SF22D/LF35D SF20G/LF30G SF12M/SF20M LF30M/FF30A FF22D/FF35D FF20G/FF30G FF12M/FF20M FF30M	 <p>Motor Side Connector Drive Side Connector Brake Power side Connector</p> <table border="1"> <thead> <tr> <th>PIN No.</th> <th>Signal</th> </tr> </thead> <tbody> <tr> <td>A</td> <td>U</td> </tr> <tr> <td>B</td> <td>V</td> </tr> <tr> <td>C</td> <td>W</td> </tr> <tr> <td>D</td> <td>Ground</td> </tr> <tr> <td>E</td> <td>BK+</td> </tr> <tr> <td>F</td> <td>BK-</td> </tr> </tbody> </table>	PIN No.	Signal	A	U	B	V	C	W	D	Ground	E	BK+	F	BK-		
					PIN No.	Signal															
A	U																				
B	V																				
C	W																				
D	Ground																				
E	BK+																				
F	BK-																				
<p>1. Motor Side Connector</p> <ul style="list-style-type: none"> PLUG Spec. : MS3108B24-10S(MS) <p>2. Drive Side Connector</p> <ul style="list-style-type: none"> U, V, W Pin Spec. : 2512 Cable Spec. : 4Cx2.5SQ or 4Cx52AWG FG Pin Spec. : 2.5x4(Ring Terminal) <p>3. Brake Power side Connector</p> <ul style="list-style-type: none"> BK Pin Spec. : 1.5x3(Ring Terminal) Cable Spec. : 2Cx07.5. S or 2Cx18AWG 																					

Note1) □ □ □ of Model Name indicates the kind and length of cable. And the declaration is as below.

Cable Length(m)	3	5	10	20
General Cable(N)	N03	N05	N10	N20
Robotic Cable(F)	F03	F05	F10	F20

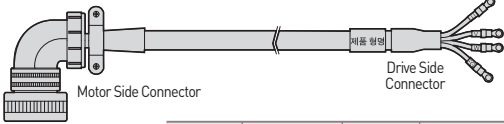
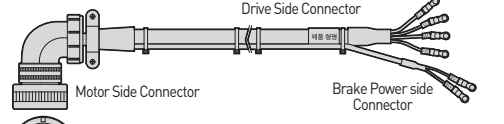
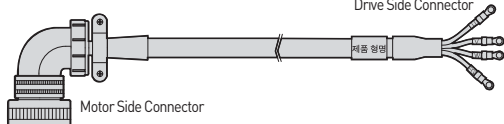
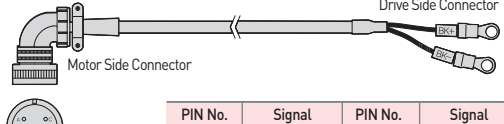
Type	Product Type	Model Name ^(Note1)	Applicable Drive	Applicable Motor	Specifications																	
For Power	Power Cable (Middle Capacity)	XLCS-P □□□JS	XDL-L7SA□□□A L7SA□□□B L7NA□□□B L7NHA□□□U L7PA□□□U	XML-SF50A SF55D/SF75D SF44G/SF60G SF44M/SG55D SG75D/SG44G SG60G/SG44M FF50A/FF55D FF75D/FF44G FF60G/FF44M FG55D/FG75D FG44G/FG60G FG44M	 <table border="1" data-bbox="1085 582 1444 660"> <thead> <tr> <th>PIN No.</th> <th>Signal</th> <th>PIN No.</th> <th>Signal</th> </tr> </thead> <tbody> <tr> <td>A</td> <td>U</td> <td>C</td> <td>W</td> </tr> <tr> <td>B</td> <td>V</td> <td>D</td> <td>Ground</td> </tr> </tbody> </table> <p>1. Motor Side Connector • Plug Spec. : MS3108B22-22S(MS)</p> <p>2. Drive Side Connector • Connecting terminal Spec. : 6x5(Ring Terminal)</p> <p>3. Cable Spec: 4Cx6SQ or 4Cx10AWG</p>	PIN No.	Signal	PIN No.	Signal	A	U	C	W	B	V	D	Ground					
					PIN No.	Signal	PIN No.	Signal														
					A	U	C	W														
					B	V	D	Ground														
For Power	Power Cable (Brake Type)	XLCS-P □□□LB	XDL-L7SA□□□A L7SA□□□B L7NA□□□B L7NHA□□□U L7PA□□□U	XML-SF50A SF55D/SF75D SF44G/SF60G SF44M/FF50A FF50D/FF75D FF44G/FF60G FF40M	 <p>1. Motor Side Connector • Plug Spec. : MS3108A24-10S(MS)</p> <p>2. Drive Side Connector • Connecting terminal Spec. : 6x5(Ring Terminal) • 4Cx6SQ or 4Cx10AWG</p> <p>3. Brake Power side Connector • Connecting terminal Spec. : 1.25x3(Ring Terminal) • Cable Spec. : 2Cx0.75SQ or 2Cx8AWG</p>																	
					For Power	Power Cable (Middle Capacity)	XLCS-P □□□MS	XDL-L7SA□□□A L7SA□□□B L7NA□□□B L7NHA□□□U L7PA□□□U	XML-SG60M SF75G/FF75G	 <table border="1" data-bbox="1085 1366 1444 1444"> <thead> <tr> <th>PIN No.</th> <th>Signal</th> <th>PIN No.</th> <th>Signal</th> </tr> </thead> <tbody> <tr> <td>A</td> <td>U</td> <td>C</td> <td>W</td> </tr> <tr> <td>B</td> <td>V</td> <td>D</td> <td>Ground</td> </tr> </tbody> </table> <p>1. Motor Side Connector • Plug Spec. : MS3108B32-17S(MS)</p> <p>2. Drive Side Connector • Connecting terminal Spec. : 10x8(Ring Terminal)</p> <p>3. Cable Spec: 4Cx10SQ or 4Cx8AWG</p>	PIN No.	Signal	PIN No.	Signal	A	U	C	W	B	V	D	Ground
										PIN No.	Signal	PIN No.	Signal									
										A	U	C	W									
B	V	D	Ground																			
For Power	Brake Cable	XLCS-P □□□SB	XDL-L7SA□□□A L7SA□□□B L7NA□□□B L7NHA□□□U L7PA□□□U	All Models of XML-SG LG FG SERIES	 <table border="1" data-bbox="1085 1736 1444 1792"> <thead> <tr> <th>PIN No.</th> <th>Signal</th> <th>PIN No.</th> <th>Signal</th> </tr> </thead> <tbody> <tr> <td>A</td> <td>BK+</td> <td>B</td> <td>BK-</td> </tr> </tbody> </table> <p>1. Motor Side Connector • Plug Spec. : MS3108B 14S-7S(MS)</p> <p>2. Drive Side Connector • Connecting terminal Spec. : 1.5x3(Ring Terminal)</p> <p>3. Cable Spec: 2Cx0.75SQ or 2Cx19AWG</p>	PIN No.	Signal	PIN No.	Signal	A	BK+	B	BK-									
					PIN No.	Signal	PIN No.	Signal														
					A	BK+	B	BK-														

Note1) □ □ □ of Model Name indicates the kind and length of cable. And the declaration is as below.

Cable Length(m)	3	5	10	20
General Cable(N)	N03	N05	N10	N20
Robotic Cable(F)	F03	F05	F10	F20



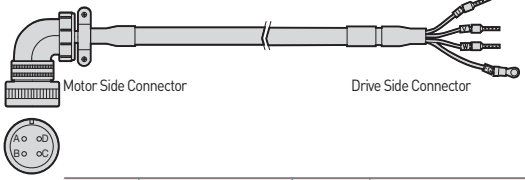
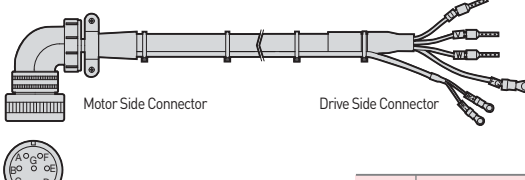
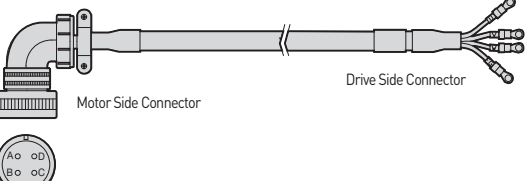



Power Cable [400V]

Type	Product Type	Model Name ^(Note1)	Applicable Drive	Applicable Motor	Specifications														
For Power	Power Cable	XLCS-P □□□HS	XDL-L7SB□□□B L7NHB□□□U	All Models of XML-SEP FEP SERIES	 <table border="1" data-bbox="973 660 1444 728"> <thead> <tr> <th>PIN No.</th> <th>Signal</th> <th>PIN No.</th> <th>Signal</th> </tr> </thead> <tbody> <tr> <td>A</td> <td>U</td> <td>C</td> <td>W</td> </tr> <tr> <td>B</td> <td>V</td> <td>D</td> <td>Ground</td> </tr> </tbody> </table> <p>1. Motor Side Connector • Plug Spec. : MS3108A 20-4S(MS)</p> <p>2. Drive Side Connector(U,V,W,FG) • U, V, W Pin Spec. : 1512(Ferrule) • FG Pin Spec. : 1.5x4(Ring Terminal)</p> <p>3. Cable Spec: 4Cx1.5SQ or 4Cx15AWG</p>	PIN No.	Signal	PIN No.	Signal	A	U	C	W	B	V	D	Ground		
PIN No.	Signal	PIN No.	Signal																
A	U	C	W																
B	V	D	Ground																
For Power	Power Cable (Brake Type)	XLCS-P □□□NB	XDL-L7SB□□□B L7NHB□□□U	All Models of XML-SEP FEP SERIES	 <table border="1" data-bbox="1268 1131 1444 1299"> <thead> <tr> <th>PIN No.</th> <th>Signal</th> </tr> </thead> <tbody> <tr> <td>A</td> <td>U</td> </tr> <tr> <td>B</td> <td>V</td> </tr> <tr> <td>C</td> <td>W</td> </tr> <tr> <td>D</td> <td>Ground</td> </tr> <tr> <td>E</td> <td>BK+</td> </tr> <tr> <td>F</td> <td>BK-</td> </tr> </tbody> </table> <p>1. Motor Side Connector • Plug Spec. : MS3108A 20-15S(MS)</p> <p>2. Drive Side Connector (U,V,W,FG) • U, V, W Pin Spec. : 1512(Ferrule) • FG Pin Spec. : 1.5 x 4(Ring Terminal)</p> <p>3. Power Cable Spec. : 4Cx1.5SQ or 4Cx15AWG</p> <p>4. Brake Power side Connector • Connecting terminal Spec. : 1.5 x 3(Ring Terminal)</p> <p>5. Brake Cable Spec. : 2Cx0.75SQ or 2Cx19AWG</p>	PIN No.	Signal	A	U	B	V	C	W	D	Ground	E	BK+	F	BK-
PIN No.	Signal																		
A	U																		
B	V																		
C	W																		
D	Ground																		
E	BK+																		
F	BK-																		
For Power	Power Cable	XLCS-P □□□IS	XDL-L7SB□□□B L7NHB□□□U	XML-[S/F]FP30A [S/F]FP22D/ [S/F]FP35D/ [S/F]FP20G/ FFP30G/ [S/F]FP12M/ [S/F]FP20M/ [S/F]GP22D/ [S/F]GP35D/ [S/F]GP20G/ FGP30G/ [S/F]GP12M/ [S/F]GP20M	 <table border="1" data-bbox="1268 1691 1444 1814"> <thead> <tr> <th>PIN No.</th> <th>Signal</th> </tr> </thead> <tbody> <tr> <td>A</td> <td>U</td> </tr> <tr> <td>B</td> <td>V</td> </tr> <tr> <td>C</td> <td>W</td> </tr> <tr> <td>D</td> <td>Ground</td> </tr> </tbody> </table> <p>1. Motor Side Connector • Plug Spec. : MS3108A 22-22S(MS)</p> <p>2. Drive Side Connector (U,V,W,FG) • U, V, W Pin Spec : 2512(Ferrule) • FG Pin Spec. : 2.5x4 (Ring Terminal)</p> <p>3. Cable Spec. : 4Cx2.5SQ or 4Cx14AWG</p>	PIN No.	Signal	A	U	B	V	C	W	D	Ground				
PIN No.	Signal																		
A	U																		
B	V																		
C	W																		
D	Ground																		

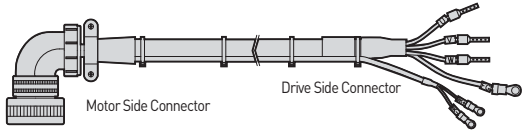
Note1) □ □ □ of Model Name indicates the kind and length of cable. And the declaration is as below.

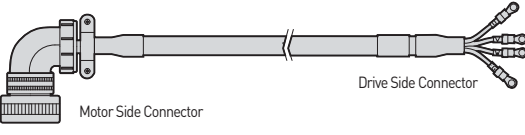
Note2) In case of 400V products, you can use Robotic Cable only.

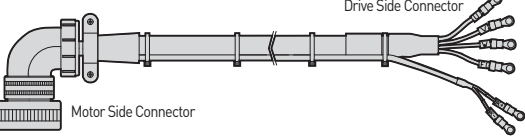
Cable Length(m)	3	5	10	20
Robotic Cable(F)	F03	F05	F10	F20

Type	Product Type	Model Name ^(Note1)	Applicable Drive	Applicable Motor	Specifications														
For Power	Power Cable (Brake Type)	XLCS-P □□□ PB	XDL-L7SB□□□ B L7NHB□□□ U	XML- [S/F]FP30A/ [S/F]FP22D/ [S/F]FP35D/ [S/F]FP20G/ FFP30G/ [S/F]FP12M/ [S/F]FP20M/ [S/F]GP22D/ [S/F]GP35D/ [S/F]GP20G/ FGP30G/ [S/F]GP12M/ [S/F]GP20M	 <p>Motor Side Connector</p> <p>Drive Side Connector</p>  <table border="1" data-bbox="1268 616 1444 784"> <thead> <tr> <th>PIN No.</th> <th>Signal</th> </tr> </thead> <tbody> <tr> <td>A</td> <td>U</td> </tr> <tr> <td>B</td> <td>V</td> </tr> <tr> <td>C</td> <td>W</td> </tr> <tr> <td>D</td> <td>Ground</td> </tr> <tr> <td>E</td> <td>BK+</td> </tr> <tr> <td>F</td> <td>BK-</td> </tr> </tbody> </table> <ol style="list-style-type: none"> Motor Side Connector <ul style="list-style-type: none"> Plug Spec. : MS3108A 24-10S(MS) Drive Side Connector <ul style="list-style-type: none"> U, V, W Pin Spec. : 2512(Ferrule) FG Pin Spec. : 2.5 x 4(Ring Terminal) Power Cable Spec. : 4Cx2.5SQ or 4Cx14AWG Brake Power side Connector <ul style="list-style-type: none"> Connecting terminal Spec. : 1.5 x 3(Ring Terminal) Brake Cable Spec. : 2Cx0.75SQ or 2Cx19AWG 	PIN No.	Signal	A	U	B	V	C	W	D	Ground	E	BK+	F	BK-
					PIN No.	Signal													
					A	U													
B	V																		
C	W																		
D	Ground																		
E	BK+																		
F	BK-																		
For Power	Power Cable (Middle Capacity)	XLCS-P □□□ JS	XDL-L7SB□□□ B L7NHB□□□ U	XML- [S/F]FP50A/ [S/F]FP55D/ [S/F]FP75D/ SFP30G/ [S/F]FP44G/ [S/F]FP60G/ [S/F]FP30M/ [S/F]FP44M/ [S/F]GP55D/ SGP30G/ [S/F]GP44G/ [S/F]GP60G/ [S/F]GP30M/ [S/F]GP44M	 <p>Motor Side Connector</p> <p>Drive Side Connector</p>  <table border="1" data-bbox="1268 1153 1444 1288"> <thead> <tr> <th>PIN No.</th> <th>Signal</th> </tr> </thead> <tbody> <tr> <td>A</td> <td>U</td> </tr> <tr> <td>B</td> <td>V</td> </tr> <tr> <td>C</td> <td>W</td> </tr> <tr> <td>D</td> <td>Ground</td> </tr> </tbody> </table> <ol style="list-style-type: none"> Motor Side Connector <ul style="list-style-type: none"> Plug Spec. : MS3108A 22-22S(MS) Drive Side Connector (U,V,W,FG) <ul style="list-style-type: none"> U, V, W Pin Spec. : 4.0x 5(Ring Terminal) Cable Spec. : 4Cx4.0SQ or 4Cx11AWG 	PIN No.	Signal	A	U	B	V	C	W	D	Ground				
					PIN No.	Signal													
					A	U													
B	V																		
C	W																		
D	Ground																		
For Power	Power Cable (Brake Type)	XLCS-P □□□ LB	XDL-L7SB□□□ B L7NHB□□□ U	XML- [S/F]FP50A/ [S/F]FP55D/ [S/F]FP75D/ SFP30G/ [S/F]FP44G/ [S/F]FP60G/ [S/F]FP30M/ [S/F]FP44M	 <p>Motor Side Connector</p> <p>Drive Side Connector</p>  <table border="1" data-bbox="1268 1579 1444 1747"> <thead> <tr> <th>PIN 번호</th> <th>신호</th> </tr> </thead> <tbody> <tr> <td>A</td> <td>U</td> </tr> <tr> <td>B</td> <td>V</td> </tr> <tr> <td>C</td> <td>W</td> </tr> <tr> <td>D</td> <td>Ground</td> </tr> <tr> <td>E</td> <td>BK+</td> </tr> <tr> <td>F</td> <td>BK-</td> </tr> </tbody> </table> <ol style="list-style-type: none"> Motor Side Connector <ul style="list-style-type: none"> Plug Spec. : MS3108A 24-10S(MS) Drive Side Connector <ul style="list-style-type: none"> U, V, W Pin Spec. : 4.0X5(Ring Terminal) Power Cable Spec. : 4Cx4.0SQ or 4Cx11AWG Brake Power side Connector <ul style="list-style-type: none"> Connecting terminal Spec. : 1.5 x 3(Ring Terminal) Brake Cable Spec. : 2Cx0.75SQ or 2Cx19AWG 	PIN 번호	신호	A	U	B	V	C	W	D	Ground	E	BK+	F	BK-
					PIN 번호	신호													
					A	U													
B	V																		
C	W																		
D	Ground																		
E	BK+																		
F	BK-																		

Note1) □ □ □ of Model Name indicates the kind and length of cable. And the declaration is as below.

Note2) In case of 400V products, you can use Robotic Cable only.

Cable Length(m)	3	5	10	20
Robotic Cable(F)	F03	F05	F10	F20

Power Cable [400V]

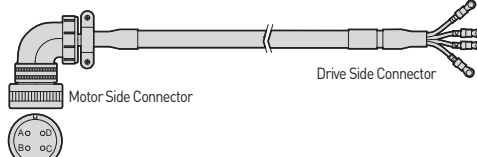
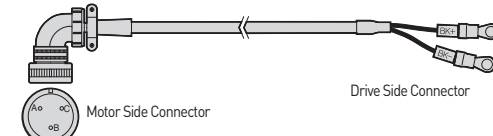
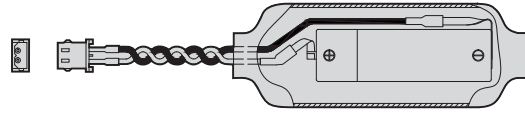



Type	Product Type	Model Name ^{Note1)}	Applicable Drive	Applicable Motor	Specifications												
For Power	Power Cable (Middle Capacity)	XLCS-P □□□MS	XDL-L7SB□□□B L7NHB□□□U	XML-[S/F]FP75G/ [S/F]GP110D/ [S/F]GP85G/ [S/F]GP110G/ [S/F]GP150G/ [S/F]GP60M/	 <table border="1"> <thead> <tr> <th>PIN No.</th> <th>Signal</th> <th>PIN No.</th> <th>Signal</th> </tr> </thead> <tbody> <tr> <td>A</td> <td>U</td> <td>C</td> <td>W</td> </tr> <tr> <td>B</td> <td>V</td> <td>D</td> <td>Ground</td> </tr> </tbody> </table> <ol style="list-style-type: none"> Motor Side Connector <ul style="list-style-type: none"> Plug Spec. : MS3108A 32-17S(MS) Drive Side Connector(U,V,W,FG) <ul style="list-style-type: none"> U, V, W Pin Spec. : 10x5(Ring Terminal) Cable Spec: 4Cx10SQ or 4Cx7AWG 	PIN No.	Signal	PIN No.	Signal	A	U	C	W	B	V	D	Ground
PIN No.	Signal	PIN No.	Signal														
A	U	C	W														
B	V	D	Ground														
For Power	Brake Cable (same with 200V)	XLCS-P □□□SB	XDL-L7SB□□□B L7NHB□□□U	All Models of XML-SGP FGP SERIES	 <p>MS3108B14S-7S (2Circuits)</p> <table border="1"> <thead> <tr> <th>PIN No.</th> <th>Signal</th> </tr> </thead> <tbody> <tr> <td>1</td> <td>BK+</td> </tr> <tr> <td>2</td> <td>BK-</td> </tr> </tbody> </table> <ol style="list-style-type: none"> Motor Side Connector <ul style="list-style-type: none"> Plug Spec. : MS3108B 14-7S(MS) Brake Power side Connector <ul style="list-style-type: none"> Connecting terminal Spec. : 1.5x3(Ring Terminal) Cable Spec. : 4Cx2.5SQ or 4Cx14AWG 	PIN No.	Signal	1	BK+	2	BK-						
PIN No.	Signal																
1	BK+																
2	BK-																
Battery For Encoder	Battery Ass'y	XLCS-BATT36	All L7 Drives for M-turn	All Model of XML-F Series	 <table border="1"> <thead> <tr> <th>PIN No.</th> <th>Signal</th> <th>Color</th> </tr> </thead> <tbody> <tr> <td>1</td> <td>BK+</td> <td>Red</td> </tr> <tr> <td>2</td> <td>BK-</td> <td>Black</td> </tr> </tbody> </table> <ol style="list-style-type: none"> PLUG Spec. : 5264-02 (Molex) PLUG Pin Spec. : 5263PBT (Molex) Battery Spec. : ER6V/3.6V, 2000mAh (TOSHIBA) 	PIN No.	Signal	Color	1	BK+	Red	2	BK-	Black			
PIN No.	Signal	Color															
1	BK+	Red															
2	BK-	Black															

Note1) □ □ □ of Model Name indicates the kind and length of cable. And the declaration is as below.

Note2) In case of 400V products, you can use Robotic Cable only.

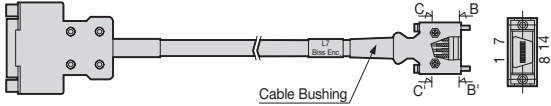
Cable Length(m)	3	5	10	20
Robotic Cable(F)	F03	F05	F10	F20

DD Motor Signal Cable

Type	Product Type	Model Name ^(Note1)	Applicable Drive	Specifications	Specifications																																			
For Signal	L7 Encoder Cable	XLCS-E □□□ZS	XDL-L7SA□□□B L7NA□□□B L7NHA□□□U L7PA□□□U	All Models of DD motor	 <p style="text-align: center;">Cable Bushing</p>																																			
					<div style="display: flex; justify-content: space-between;"> <div style="width: 45%;">  <p>D-sub(15pin)(female)</p> </div> <div style="width: 45%;"> <table border="1"> <thead> <tr> <th colspan="4">D.D SERVO ENCODER CABLE</th> </tr> <tr> <th>NO</th> <th>Encoder Signal</th> <th>NO</th> <th>Encoder Signal</th> </tr> </thead> <tbody> <tr><td>1</td><td>MA</td><td>9</td><td>+5V</td></tr> <tr><td>2</td><td>SLO</td><td>10</td><td>-</td></tr> <tr><td>3</td><td>GND_B</td><td>11</td><td>-</td></tr> <tr><td>4</td><td>OV</td><td>12</td><td>-</td></tr> <tr><td>5</td><td>SHELD</td><td>13</td><td>-</td></tr> <tr><td>6</td><td>MA</td><td>14</td><td>-</td></tr> <tr><td>7</td><td>SLO</td><td>15</td><td>-</td></tr> <tr><td>8</td><td>+5V</td><td></td><td>-</td></tr> </tbody> </table> </div> </div> <div style="display: flex; justify-content: space-around; margin-top: 10px;"> <div style="width: 45%;">  <p>(ENCODER CONNECTOR) (Motor Connector)</p> </div> <div style="width: 45%;">  <p>Biss Serial Encoder (Driver Connector)</p> </div> </div>	D.D SERVO ENCODER CABLE				NO	Encoder Signal	NO	Encoder Signal	1	MA	9	+5V	2	SLO	10	-	3	GND_B	11	-	4	OV	12	-	5	SHELD	13	-	6	MA	14	-	7	SLO	15
D.D SERVO ENCODER CABLE																																								
NO	Encoder Signal	NO	Encoder Signal																																					
1	MA	9	+5V																																					
2	SLO	10	-																																					
3	GND_B	11	-																																					
4	OV	12	-																																					
5	SHELD	13	-																																					
6	MA	14	-																																					
7	SLO	15	-																																					
8	+5V		-																																					
					<p>3. Cable Spec. : 3Px0.25SQ</p>																																			

- Motor Side Connector**
 - Connector(D-SUB) : DA-15PF-N(Female connector)
 - Connector CASE(D-SUB) : SK-15H-1A
- Drive Side Connector**
 - CASE Spec. : 10314-52A0-008(3M)
 - Connector Spec. : 10114-3000VE(3M)

3. Cable Spec. : 3Px0.25SQ

DD Motor Power Cable

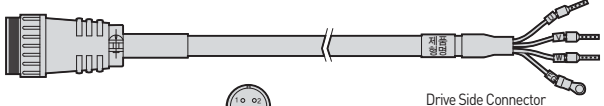
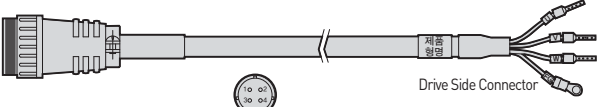
Type	Product Type	Model Name ^(Note1)	Applicable Drive	Specifications	Specifications												
For Power	Power Cable	XLCS-PN □□□YS	XDL-L7SA□□□B L7NA□□□B L7NHA□□□U L7PA□□□U	XML-DB03D/ DB06D/ DB09D/ DC06D/ DC12D/ DC18D/ DD12D/ DD22D/ DD34D/ DE40D/ DE60D	 <p style="text-align: center;">Drive Side Connector</p>												
					<div style="display: flex; justify-content: space-between;"> <div style="width: 45%;"> <p>Nanaboshi Electronic NJC-24-4-ADF(Female) (Motor side connector)</p> </div> <div style="width: 45%;"> <table border="1"> <thead> <tr> <th>Item</th> <th>Signal</th> <th>PIN No.</th> <th>Line Color</th> </tr> </thead> <tbody> <tr><td rowspan="4">Motor</td><td>U</td><td>1</td><td>Red</td></tr> <tr><td>V</td><td>2</td><td>White</td></tr> <tr><td>W</td><td>3</td><td>Black</td></tr> <tr><td>Ground</td><td>4</td><td>Green</td></tr> </tbody> </table> </div> </div>	Item	Signal	PIN No.	Line Color	Motor	U	1	Red	V	2	White	W
Item	Signal	PIN No.	Line Color														
Motor	U	1	Red														
	V	2	White														
	W	3	Black														
	Ground	4	Green														
For Power	Power Cable	XLCS-PN □□□ZS	XDL-L7SA□□□B L7NA□□□B L7NHA□□□U L7PA□□□U	XML-DFA1G/ DFA6G	 <p style="text-align: center;">Drive Side Connector</p>												
					<div style="display: flex; justify-content: space-between;"> <div style="width: 45%;"> <p>Nanaboshi Electronic NJC-24-4-ADF(Female) (Motor side connector)</p> </div> <div style="width: 45%;"> <table border="1"> <thead> <tr> <th>Item</th> <th>Signal</th> <th>PIN No.</th> <th>Line Color</th> </tr> </thead> <tbody> <tr><td rowspan="4">Motor</td><td>U</td><td>1</td><td>Red</td></tr> <tr><td>V</td><td>2</td><td>White</td></tr> <tr><td>W</td><td>3</td><td>Black</td></tr> <tr><td>Ground</td><td>4</td><td>Green</td></tr> </tbody> </table> </div> </div>	Item	Signal	PIN No.	Line Color	Motor	U	1	Red	V	2	White	W
Item	Signal	PIN No.	Line Color														
Motor	U	1	Red														
	V	2	White														
	W	3	Black														
	Ground	4	Green														

Note1) □□□ of Model Name indicates the kind and length of cable. And the declaration is as below.

Cable Length(m)	3	5	10	20
Robotic Cable(F)	F03	F05	F10	F20
General Cable(N)	N03	N05	N10	N20

Signal Cable

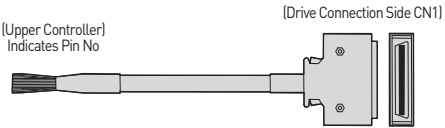
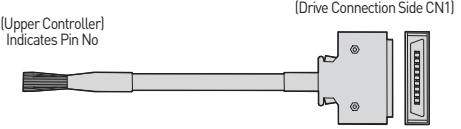
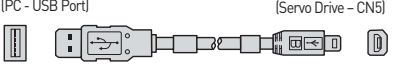
Type	Product Type	Model Name ^(Note1)	Applicable Motor	Specifications							
For Signal	CN1 Cable	XLC-CN1□□A	XDL-L7S□□□B XDL-L7NH□□□U	 <p>Drive Side Connection(CN1)</p> <ul style="list-style-type: none"> • Case Spec. : 10350-52A0-008(3M) • Connector Spec. : 10150-3000VE(3M) • Cable Spec. : 20276-SB 25P(AWG28) 							
	(Pin No. Display)										
	NO	I/O Signal	NO		I/O Signal	NO	I/O Signal	NO	I/O Signal	NO	I/O Signal
	1	TRQCOM	11		PR+	21	SPD3	31	/BO	41	RDY-
	2	REFCOM	12		PR-	22	SPD2	32	A0	42	TLOUT
	3	PZO	13		PCON	23	SPD1	33	/A0	43	ZSPD
	4	ZO	14		GAIN2(SEN)	24	GND	34	+15V	44	BRAKE
	5	/ZO	15		PCLEAR	25	GND	35	-15V	45	INSPD/INPOS
	6	SRO	16		TLIMIT	26	SETCOM	36	GND	46	DIR
	7	/SRO	17		ALMRST	27	SPDCOM	37	GND	47	SVON
8	GND	18	EMG	28	MONIT1	38	ALARM+	48	STOP		
9	RF+	19	CWLIM	29	MONIT2	39	ALARM-	49	PULCOM		
10	PF-	20	CCWLIM	30	BO	40	RDY+	50	+24Vin		
For Signal	CN1 Cable	XLCS-CN1□□A	XDL-L7S□□□B XDL-L7NH□□□U	 <p>Drive Side Connection(CN1)</p> <ul style="list-style-type: none"> • Case Spec. : 10320-52A0-008(3M) • Connector Spec. : 10120-3000VE(3M) • Cable Spec. : ROW-SB0.1C ×20C(AWG28) 							
	(Pin No. Display)										
	NO	Signal	NO		Signal	NO	Signal	NO	Signal		
	1	BRAKE+	6		24V	11	HOME	16	Spare Pin		
	2	BRAKE-	7		CWL	12	ALMRST	17	RDY+		
	3	ALARM+	8		CCWL	13	DI1	18	RDY-		
4	ALARM-	9	PROBE1	14	DI2	19	DO1+				
5	Spare Pin	10	PROBE2	15	Spare Pin	20	DO1-				
For Signal	Communication Cable	XLCS-CN5L7U	All Models of XDL-L7 SERIES	 <ol style="list-style-type: none"> 1. PC Side Connector : USB A Plug 2. Drive Side Connector(CN5) : Mini USB 5P Plug 3. Electric Requirements Spec : Double Shielded, Twisted Pair, EMI-filter attached type (Ex. : KU-AMB518, SANWA) 4. Only 1.8m length of cable is available to use 							

Note1 □□□ of Model Name indicates the kind and length of cable. And the declaration is as below.

Cable Length(m)	1	2	3	5
General Cable(N)	N01	N02	N03	N05
Robotic Cable(F)	F01	F02	F03	F05

Connector

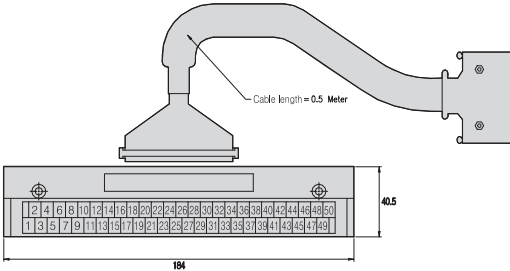
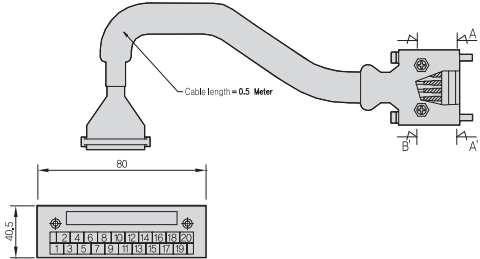
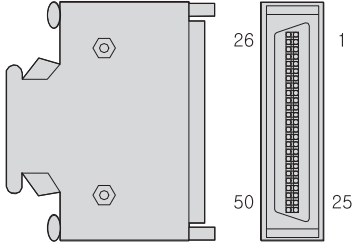
Type	Product Type	Model Name ^(Note1)	Applicable Motor	Specifications																																																																																																													
T/B	CN1 T/B	XLC- VSCN1T □□	XDL-L7S □□ □B XDL-L7NH □□ □U	 <ul style="list-style-type: none"> • Extended CN1 T/B for VS/L7S • Available Cable Length : 0.5[m], 1[m], 1.5[m], 2[m], 3[m] 																																																																																																													
	<p>(Pin No. Display)</p> <table border="1"> <thead> <tr> <th>NO</th> <th>I/O Signal</th> <th>NO</th> <th>I/O Signal</th> <th>NO</th> <th>I/O Signal</th> <th>NO</th> <th>I/O Signal</th> <th>NO</th> <th>I/O Signal</th> </tr> </thead> <tbody> <tr><td>1</td><td>TRQCOM</td><td>11</td><td>PR+</td><td>21</td><td>SPD3</td><td>31</td><td>/BO</td><td>41</td><td>RDY-</td></tr> <tr><td>2</td><td>REFCOM</td><td>12</td><td>PR-</td><td>22</td><td>SPD2</td><td>32</td><td>A0</td><td>42</td><td>TLOUT</td></tr> <tr><td>3</td><td>PZO</td><td>13</td><td>PCON</td><td>23</td><td>SPD1</td><td>33</td><td>/A0</td><td>43</td><td>ZSPD</td></tr> <tr><td>4</td><td>ZO</td><td>14</td><td>GAIN2(SEN)</td><td>24</td><td>GND</td><td>34</td><td>+15V</td><td>44</td><td>BRAKE</td></tr> <tr><td>5</td><td>/ZO</td><td>15</td><td>PCLEAR</td><td>25</td><td>GND</td><td>35</td><td>-15V</td><td>45</td><td>INSPD/INPOS</td></tr> <tr><td>6</td><td>SRO</td><td>16</td><td>TLIMIT</td><td>26</td><td>SETCOM</td><td>36</td><td>GND</td><td>46</td><td>DIR</td></tr> <tr><td>7</td><td>/SRO</td><td>17</td><td>ALMRST</td><td>27</td><td>SPDCOM</td><td>37</td><td>GNDA</td><td>47</td><td>SVON</td></tr> <tr><td>8</td><td>GNDA</td><td>18</td><td>EMG</td><td>28</td><td>MONIT1</td><td>38</td><td>ALARM+</td><td>48</td><td>STOP</td></tr> <tr><td>9</td><td>RF+</td><td>19</td><td>CWLIM</td><td>29</td><td>MONIT2</td><td>39</td><td>ALARM-</td><td>49</td><td>PULCOM</td></tr> <tr><td>10</td><td>PF-</td><td>20</td><td>CCWLIM</td><td>30</td><td>BO</td><td>40</td><td>RDY+</td><td>50</td><td>+24Vin</td></tr> </tbody> </table>				NO	I/O Signal	NO	I/O Signal	NO	I/O Signal	NO	I/O Signal	NO	I/O Signal	1	TRQCOM	11	PR+	21	SPD3	31	/BO	41	RDY-	2	REFCOM	12	PR-	22	SPD2	32	A0	42	TLOUT	3	PZO	13	PCON	23	SPD1	33	/A0	43	ZSPD	4	ZO	14	GAIN2(SEN)	24	GND	34	+15V	44	BRAKE	5	/ZO	15	PCLEAR	25	GND	35	-15V	45	INSPD/INPOS	6	SRO	16	TLIMIT	26	SETCOM	36	GND	46	DIR	7	/SRO	17	ALMRST	27	SPDCOM	37	GNDA	47	SVON	8	GNDA	18	EMG	28	MONIT1	38	ALARM+	48	STOP	9	RF+	19	CWLIM	29	MONIT2	39	ALARM-	49	PULCOM	10	PF-	20	CCWLIM	30	BO	40	RDY+	50
NO	I/O Signal	NO	I/O Signal	NO	I/O Signal	NO	I/O Signal	NO	I/O Signal																																																																																																								
1	TRQCOM	11	PR+	21	SPD3	31	/BO	41	RDY-																																																																																																								
2	REFCOM	12	PR-	22	SPD2	32	A0	42	TLOUT																																																																																																								
3	PZO	13	PCON	23	SPD1	33	/A0	43	ZSPD																																																																																																								
4	ZO	14	GAIN2(SEN)	24	GND	34	+15V	44	BRAKE																																																																																																								
5	/ZO	15	PCLEAR	25	GND	35	-15V	45	INSPD/INPOS																																																																																																								
6	SRO	16	TLIMIT	26	SETCOM	36	GND	46	DIR																																																																																																								
7	/SRO	17	ALMRST	27	SPDCOM	37	GNDA	47	SVON																																																																																																								
8	GNDA	18	EMG	28	MONIT1	38	ALARM+	48	STOP																																																																																																								
9	RF+	19	CWLIM	29	MONIT2	39	ALARM-	49	PULCOM																																																																																																								
10	PF-	20	CCWLIM	30	BO	40	RDY+	50	+24Vin																																																																																																								
T/B	CN1 T/B	XLCS-L7NCN1T- □□	XDL-L7S □□ □B XDL-L7NH □□ □U	 <ul style="list-style-type: none"> • Extended CN1 T/B for L7N • Available Cable Length : 0.5[m], 1[m], 1.5[m], 2[m] 																																																																																																													
	<p>(Pin No. Display)</p> <table border="1"> <thead> <tr> <th>NO</th> <th>Signal</th> <th>NO</th> <th>Signal</th> <th>NO</th> <th>Signal</th> <th>NO</th> <th>Signal</th> </tr> </thead> <tbody> <tr><td>1</td><td>BRAKE+</td><td>6</td><td>24V</td><td>11</td><td>HOME</td><td>16</td><td>Spare Pin</td></tr> <tr><td>2</td><td>BRAKE-</td><td>7</td><td>CWL</td><td>12</td><td>ALMRST</td><td>17</td><td>RDY+</td></tr> <tr><td>3</td><td>ALARM+</td><td>8</td><td>CCWL</td><td>13</td><td>DI1</td><td>18</td><td>RDY-</td></tr> <tr><td>4</td><td>ALARM-</td><td>9</td><td>PROBE1</td><td>14</td><td>DI2</td><td>19</td><td>DO1+</td></tr> <tr><td>5</td><td>Spare Pin</td><td>10</td><td>PROBE2</td><td>15</td><td>Spare Pin</td><td>20</td><td>DO1-</td></tr> </tbody> </table>				NO	Signal	NO	Signal	NO	Signal	NO	Signal	1	BRAKE+	6	24V	11	HOME	16	Spare Pin	2	BRAKE-	7	CWL	12	ALMRST	17	RDY+	3	ALARM+	8	CCWL	13	DI1	18	RDY-	4	ALARM-	9	PROBE1	14	DI2	19	DO1+	5	Spare Pin	10	PROBE2	15	Spare Pin	20	DO1-																																																													
NO	Signal	NO	Signal	NO	Signal	NO	Signal																																																																																																										
1	BRAKE+	6	24V	11	HOME	16	Spare Pin																																																																																																										
2	BRAKE-	7	CWL	12	ALMRST	17	RDY+																																																																																																										
3	ALARM+	8	CCWL	13	DI1	18	RDY-																																																																																																										
4	ALARM-	9	PROBE1	14	DI2	19	DO1+																																																																																																										
5	Spare Pin	10	PROBE2	15	Spare Pin	20	DO1-																																																																																																										
CN	CN1 Connector	XLC-CN1NNA	XDL-L7S □□ □B XDL-L7NH □□ □U	 <ul style="list-style-type: none"> • Case Spec. : 10350-52A0-008(3M) • Connector Spec. : 10150-3000VE(3M) 																																																																																																													

Note1) □ □ □ of Model Name indicates the kind and length of cable. And the declaration is as below.

XLC-VSCN1T

Cable Length(m)	0.5	1	2	3
Declaration	None	01	02	03

XLCS-L7NCN1T

Cable Length(m)	0.5	1	2	3
Declaration	None	01	02	03

Connector

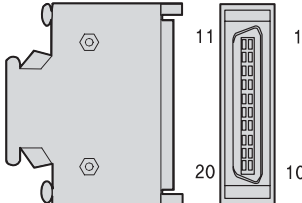
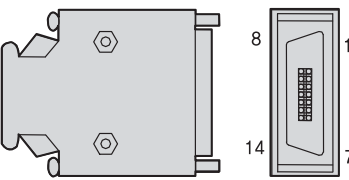
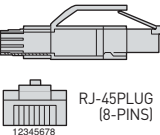
<p>CN</p>	<p>CN1 Connector</p>	<p>XLC-CN2NNA</p>	<p>XDL- L7NA□□□B L7NH□□□U</p>	 <p>• Case Spec. : 10320-52A0-008(3M) • Connector Spec. : 10120-3000VE(3M)</p>																														
<p>CN</p>	<p>CN2 Connector</p>	<p>XLC-CN3NNA</p>	<p>All models of XDL- L7 SERIES</p>	 <p>• Case Spec. : 10314-52A0-008(3M) • Connector Spec. : 10114-3000VE(3M)</p>																														
<p>CN</p>	<p>CN3 CN4 EtherCAT Connector</p>	<p>XLCS-CN4NNA</p>	<p>XDL- L7NA□□□B L7NH□□□U</p>	 <p>RJ-45 PLUG (8-PINS) 12345678</p> <table border="1" data-bbox="1157 1232 1396 1456"> <thead> <tr> <th>PIN No.</th> <th>Signal</th> <th>Line Color</th> </tr> </thead> <tbody> <tr> <td>1</td> <td>TX/RX0 Plus</td> <td>White/Orange</td> </tr> <tr> <td>2</td> <td>TX/RX0 Minus</td> <td>Orange</td> </tr> <tr> <td>3</td> <td>TX/RX1 Plus</td> <td>White/Green</td> </tr> <tr> <td>4</td> <td>TX/RX2 Plus</td> <td>Blue</td> </tr> <tr> <td>5</td> <td>TX/RX2 Minus</td> <td>White/Blue</td> </tr> <tr> <td>6</td> <td>TX/RX1 Minus</td> <td>Green</td> </tr> <tr> <td>7</td> <td>TX/RX3 Plus</td> <td>White/Brown</td> </tr> <tr> <td>8</td> <td>TX/RX3 Minus</td> <td>Brown</td> </tr> <tr> <td colspan="2">Plate</td> <td>SHILDE</td> </tr> </tbody> </table> <p>Note1) EtherCAT use only 4wires(1, 2, 3, 6)</p>	PIN No.	Signal	Line Color	1	TX/RX0 Plus	White/Orange	2	TX/RX0 Minus	Orange	3	TX/RX1 Plus	White/Green	4	TX/RX2 Plus	Blue	5	TX/RX2 Minus	White/Blue	6	TX/RX1 Minus	Green	7	TX/RX3 Plus	White/Brown	8	TX/RX3 Minus	Brown	Plate		SHILDE
PIN No.	Signal	Line Color																																
1	TX/RX0 Plus	White/Orange																																
2	TX/RX0 Minus	Orange																																
3	TX/RX1 Plus	White/Green																																
4	TX/RX2 Plus	Blue																																
5	TX/RX2 Minus	White/Blue																																
6	TX/RX1 Minus	Green																																
7	TX/RX3 Plus	White/Brown																																
8	TX/RX3 Minus	Brown																																
Plate		SHILDE																																
<p>CN</p>	<p>STO Cable</p>	<p>XLCS-STO□□A</p>	<p>XDL- L7NA□□□B L7NH□□□U</p>	<table border="1" data-bbox="1157 1624 1396 1825"> <thead> <tr> <th>PIN No.</th> <th>IO Signal</th> <th>Color</th> </tr> </thead> <tbody> <tr> <td>1</td> <td>NC</td> <td>-</td> </tr> <tr> <td>2</td> <td>NC</td> <td>-</td> </tr> <tr> <td>3</td> <td>HWBB1 Minus</td> <td>Orange</td> </tr> <tr> <td>4</td> <td>HWBB1 Plus</td> <td>Orange</td> </tr> <tr> <td>5</td> <td>HWBB2 Minus</td> <td>Yellow</td> </tr> <tr> <td>6</td> <td>HWBB2 Plus</td> <td>Yellow</td> </tr> <tr> <td>7</td> <td>EDM Plus</td> <td>White</td> </tr> <tr> <td>8</td> <td>EDM Minus</td> <td>White</td> </tr> </tbody> </table> <p>1. Cable Length • Only 0.3[m], 1[m], 3[m] of Cable is available to use.</p> <p>2. Connector Model Name : APC-ST000A</p> <p>* Caution During assembly of connector, It can be broken easily without</p>	PIN No.	IO Signal	Color	1	NC	-	2	NC	-	3	HWBB1 Minus	Orange	4	HWBB1 Plus	Orange	5	HWBB2 Minus	Yellow	6	HWBB2 Plus	Yellow	7	EDM Plus	White	8	EDM Minus	White			
PIN No.	IO Signal	Color																																
1	NC	-																																
2	NC	-																																
3	HWBB1 Minus	Orange																																
4	HWBB1 Plus	Orange																																
5	HWBB2 Minus	Yellow																																
6	HWBB2 Plus	Yellow																																
7	EDM Plus	White																																
8	EDM Minus	White																																

200V Braking Resistor

*Option braking resistors are selectable items for user's need.

Type	Product Type	Model Name ^{Note1)}	Applicable Motor	Specifications
Resistor	Braking Resistor	XLCS-140R50	XDL- L7 □ A001 □ L7 □ A002 □ L7 □ A004 □	<p>• IRH 140W 50ohm</p>
Resistor	Braking Resistor	XLCS-300R30	XDL- L7 □ A008 □ L7 □ A010 □	<p>• IRV 300W 30ohm</p>
Resistor	Braking Resistor	XLC-600R30	XDL- L7 □ A020 □ L7 □ A035 □	<p>IRV 600W 30ohm * L7 □ A020 □ - 2pcs(Parallel Connection) L7 □ A030 □ - 3pcs(Parallel Connection)</p> <p>IRV 600W 28ohm * L7 □ A050 □ - 4pcs(Parallel Connection)</p> <p>Note1) IRV 600S 30ohm and 600S 28ohm have the same external dimensions.</p>
		XLC-600R28	XDL- L7 □ A050 □(4P)	

Note1) L7 Series 100W-7.5kW has the internal basic braking resistor. If the machine requires short deceleration time frequently, refer to table above and apply the appropriate braking resistor.

400V Braking Resistor

*Option braking resistors are selectable items for user's need.

Type	Product Type	Model Name ^[Note1]	Applicable Motor	Specifications
Resistor	Braking Resistor	XLCS-300R82 82[Ω]/300W	XDL-L7□B010□	<p>IRV300-82Ω</p>
Resistor	Braking Resistor	XLCS-600R140 70Ω/1200W (140Ω / 600W ×2P)	XDL-L7□B020□ L7□B035□	<p>IRV600-140Ω</p>
Resistor	Braking Resistor	XLCS-600R75 25Ω/800W (75Ω / 600W ×3P)	XDL-L7□B75□	<p>IRV600-75Ω</p>
Resistor	Braking Resistor	XLCS-2000R13.4 13.4Ω/2000W	XDL-L7□B150□	<p>IRM2000-13.4Ω</p>

[Note1] L7 Series 100W-7.5kW has the internal basic braking resistor. If the machine requires short deceleration time frequently, refer to table above and apply the appropriate braking resistor.





Application

Contents

Motion Module [EtherCAT] -----	122
Positioning Module(EtherCAT) -----	123
Positioning Module [APM] -----	124
Positioning Module [XPM] -----	125
XG-PM-----	126
Positioning Module/External Device Interface--	127
Worldwide Network-----	138

Features

- 32 axes (master) and 4 axes (virtual) control
- EtherCAT CoE supported servo drive
- Communication cycle : 1ms
- Built-in DI/DO 8 points each and EtherCAT I/O 512 points
- Program 2MB
- External encoder input 2ch (line drive)
- Max. transmission distance : 100m



Specifications

Item		XGF-M32E
Communication		EtherCAT (CoE : CANopen over EtherCAT)
Number of axis	Real	32 axes
	Virtual	4axes
	I/O	Input/output 8 points each (built-in) EtherCAT I/O connection available
Control period		1ms, 2ms, 4ms (same as main task period)
Control unit		Pulse, mm, inch, degree
I/O	Internal	Input 8 points, output 8 points
	External	EtherCAT I/O 4 ea (max. 256 points)
Motion Program	No. of program	Max. 256 ea
	Capacity	Max. 2Mbyte
	Language	LD(FB), ST
	Position data	6400 points/all aixs
Control method		Position, Velocity, Torque(Servo drivers support) control, Synchronous control, Interpolation control
Range of position/velocity		± LREAL, 0
Acc. Dec. process		Trapezoid type, S-type (Setting to specify the Jerk at function block)
Acc. Dec. time		1 ~ 2, 147, 483, 647ms
Manual operation		JOG operation
Torque unit		Rated torque % designation
Encoder input	Channel	2 channels
	Max. input	Max. 500Kpps
	Input method	Line drive input (RS-422A IEC specification) Open collector output type encoder
	Input type	CW/CCW, Pulse/Dir, Phase A/B
Max. distance		100m
Communication cable		Over CAT.5 STP(Shielded Twisted-pair) cable
Error indication		Indicated by LED
Communication status indication		Indicated by LED
Occupied point I/O		Variable: 16 point, Fixed: 64 point
Communication physical layer		100BASE-TX
Consumable current(mA)		900mA
Weight		122g

Features

- XGF-PN8B : Standard EtherCAT Network Support(XGT Servo XDL Series)
- Direct connect with servo driver Max 8
- 2~8 axis linear interpolation, 2axis circular interpolation, 3axis helical interpolation
- Position, speed, feed control is possible through the various operation
- Parameters, the operation data stored in the FRAM(without Battery)
- CAM for controlling up to eight different types of CAM data



Specifications

Item		XGF-PN8B			
Number of axis		8 axis			
Interpolation		2-8 axis linear, 2axis circular, 3axis helical interpolation			
Control method		Position, speed, Speed/position, position/speed position/torque, Feed control			
Setting unit		pulse, mm, inch, degree			
Positioning data		Each axis has 400 data items (Operation step number 1~400). It is available to set with software package or programming.			
XG-PM	Port	RS-232C, USB			
	Data	Basic, expansion, manual, servo parameter, operation data, cam data, command information			
	Monitor	Operation, trace, input sort, error information			
Back-up		FRAM(parameter, operation data) no battery			
Positioning	Positioning method	Absolute/Incremental			
	Position address range		Absolute	Incremental	Speed/position, position/speed conversion control
		mm	-214748364.8 ~ 214748364.7 (μm)	-214748364.8 ~ 214748364.7 (μm)	-214748364.8 ~ 214748364.7 (μm)
		inch	-21474.83648 ~ 21474.83647	-21474.83648 ~ 21474.83647	-21474.83648 ~ 21474.83647
		degree	-21474.83648 ~ 21474.83647	-21474.83648 ~ 21474.83647	-21474.83648 ~ 21474.83647
		pulse	-2147483648 ~ 2147483647	-2147483648 ~ 2147483647	-2147483648 ~ 2147483647
	Position speed range	mm	0.01 ~ 20000000.00 (mm/Min)		
		inch	0.001 ~ 2000000.000 (inch/Min)		
		degree	0.001 ~ 2000000.000 (degree/Min)		
		pulse	1 ~ 20.000.000 (pulse/Sec)		
RPM		0.1 ~ 100000.0 (RPM)			
Accel/Decel pattern	Trapezoidal & S-curve acceleration/deceleration				
Accel/Decel time	1~2.147.483.647 ms				
Manual		Jog/ MPG/ inching			
Homing method		Max+Z(Forward), Min+Z(Backward), Near-point+Z(Forward, Backward), Max+near-point+Z(Forward, Min+near-point+Z(Backward), Z(Forward, Backward), near-point(Forward, Backward)			
The ability to Change speed		Absolute/Percent			
Torque		Rated torque %			
Absolute position System		0 (Absolute encoder type servo)			
Encoder input	Channel	2 Channel			
	Max. Input	Max. 200 Kpps			
	Input method	line-drive input (RS-422A IEC), open collector output type			
	Type	CW/CCW, Pulse/Dir, Phase A/B			
Connector		12 Pin connector			
Communication Cycle		800 μs			
Max. distance		100 m			
Cable		STP(Shielded Twisted-pair) cable			
Error display		LED			
Operation display		LED			
Occupied points of I/O		64points (Fixed type), 16points (Variable type)			
Current consumption (mA)		500 mA			
Weight(kg)		115 g			

Features

- Highly reliable position control with LSIS ASIC-embedded processor
- Enhanced control with fast control processing speed
- High-speed motor control (Max. pulse output: 1Mbps)
- Circular/linear interpolation, separate/synchronous operation
- Trapezoidal & S-curve acceleration/deceleration
- Easy and quick control through external input (JOG operation included)
- Encoder input support
- High-speed processing of command (4ms)
- Easy to set positioning parameters (Windows)
- Monitoring/Tracking/Simulation
- Available to edit operation parameter data in EXCEL
- Self-diagnosis
- Real-time information and solution for each error



Specifications

Item	Specifications		
	XGF-PO1A, XGF-PD1A	XGF-PO2A, XGF-PD2A	XGF-PO3A, XGF-PD3A
Number of axis	1	2	3
Interpolation		2-axis linear interpolation, 2-axis circular interpolation	2/3-axis linear interpolation, 2-axis circular interpolation
Control method	Position control, speed control, speed/position control, position/speed control		
Setting unit	Pulse, mm, inch, degree		
Positioning data	Each axis has 400 data items (Operation step number 1~400). It is available to set with software package or programming.		
Software package	Available (Connected with RS-232C Port of CPU module)		
Data backup	Flash memory (No battery)		
Positioning	Positioning method		Absolute / relative method
	Position speed range	mm	-214748364.8 ~ 214748364.7 (μm)
		Inch	-21474.83648 ~ 21474.83647
		Degree	-21474.83648 ~ 21474.83647
		Pulse	-2147483648 ~ 2147483647
	Type		XGF-PO□A: Open collector, XGF-PD□A: Line Driver
	Position speed range	mm	0.01 ~ 20000000.00 (mm/min)
		Inch	0.001 ~ 2000000.000 (inch/min)
		Degree	0.001 ~ 2000000.000 (degree/min)
		Pulse	XGF-PO□A: 1~200,000 (pulse/sec), XGF-PD□A: 1~1,000,000 (pulse/sec)
Accel/Decel pattern		Trapezoidal & S-curve acceleration/deceleration	
Accel/Decel time		1 ~ 65,535mm	
Max. output pulse	XGF-PO□A: 200Kpps / XGF-PD□A: 1Mpps		
Max. distance	XGF-PO□A: 2m / XGF-PD□A: 10m		
Max. encoder input	200 Kpps		
Error display	LED		
Operation display	LED		
Connection connector	40 Pin connector		
Size of cable	AWG #24		
Occupied points of I/O	64 points (Fixed type), 16 points (Variable type)		
Current consumption (mA)	XGF-PO1A: 340	XGF-PO2A: 360	XGF-PO3A: 400
	XGF-PD1A: 510	XGF-PD2A: 790	XGF-PD3A: 860
Weight (kg)	0.12	0.13	0.135

* XGF-PO□0: Open Collector type, □: Number of axis
XGF-PD□0: Line Drive type, □: Number of axis

Features

- Max 4Axis, Max pulse output 4Mpps
- Circular/linear/ellipse/helical interpolation
- Asymmetric acceleration and deceleration driving
- FRAM parameter
- XG-PM monitoring, simulation, trace
- CAM profile program



Specifications

Item	XGF-P01H XGF-PD1H	XGF-P02H XGF-PD2H	XGF-P03H XGF-PD3H	XGF-P04H XGF-PD4H
Number of axis	1 axis	2 axis	3 axis	4 axis
Interpolation	-	Circular, linear, ellipse	Circular, linear, helical, ellipse	
Control method	Position control, speed control, speed/position control, position/speed control, FEED			
Positioning data	Each axis has 400 data items (Operation step number 1-400). It is available to set with XG-PM or programming.			
Configuration Tool	XG-PM (Connected with USB or RS-232C Port of CPU module)			
Data backup	FRAM (Parameter, Operation data), Flash memory (CAM Data), No battery			
Pulse output	XGF-POxH: Open collector, XGF-PDxH: line driver			
Positioning	Positioning method	Absolute / Incremental		
	Position address range	mm	-214,748,364.8 ~ 214,748,364.7 (μm)	
		inch	-21,474.83648 ~ 21,474.83647	
		degree	-21,474.83648 ~ 21,474.83647	
		pulse	-2,147,483,648 ~ 2,147,483,647	
	Position address speed	mm	0.01 ~ 20,000,000.00 (mm/min)	
		inch	0.001 ~ 2,000,000.000 (inch/min)	
		degree	0.001 ~ 2,000,000.000 (degree/min)	
pulse		1 ~ 500,000 (pulse/sec): Open collector, 1 ~ 4,000,000 (pulse/sec): line driver		
RPM	0.1 ~ 100,000.0 (RPM)			
Accel/Decel pattern	Trapezoidal & S-curve acceleration/deceleration			
Accel/Decel time	0~2,147,483,647ms			
Max. output pulse	Open collector: 500kpps, line driver: 4Mpps			
Max. distance	Open collector: 5m, line driver: 10m			
Max. encoder input	500kpps			
Error display	LED			
Size of cable	AWG #24			
Occupied points of I/O	64 points (Fixed type), 16 points (Variable type)			
Connection connector	40Pin		80Pin	
Current consumption (mA)	XGF-P01H:400mA	XGF-P02H:410mA	XGF-P03H:420mA	XGF-P04H:430mA
	XGF-PD1H:520mA	XGF-PD2H:600mA	XGF-PD3H:850mA	XGF-PD4H:890mA
Weight (kg)	120		130	

Features

- Configuration tool with updated APM software package
- All models can be used for XGT Positioning module(APM, XPM)
- Simultaneous communications can be accessed with XG5000
- Powerful simulation, trace, monitoring



System View



Data trace(trend graph)

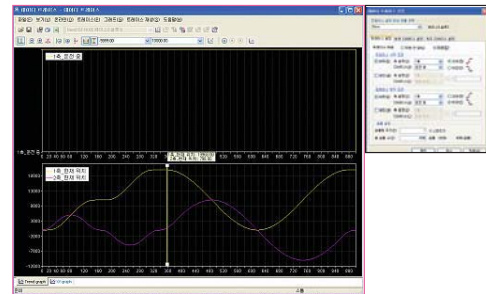

Data trace(XY graph)

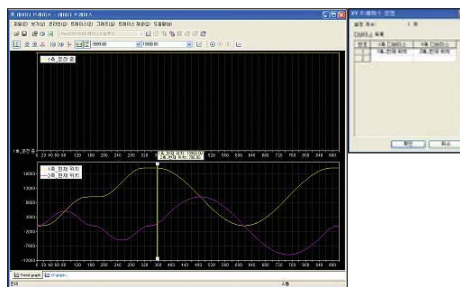

XYZ trend(3D View)

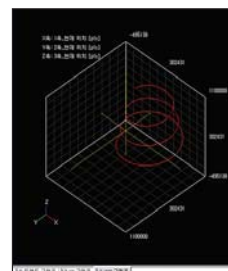

XYZ monitor(2D View)

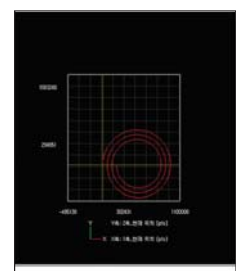

CAM control profile

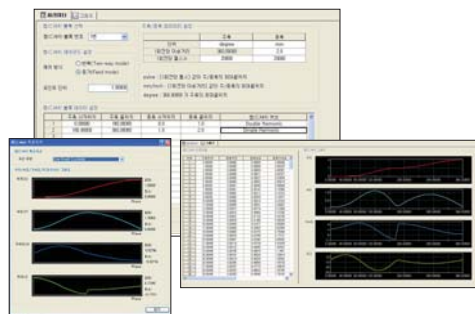

Simulation



XGF-PO1/2/3A (Open Collector)

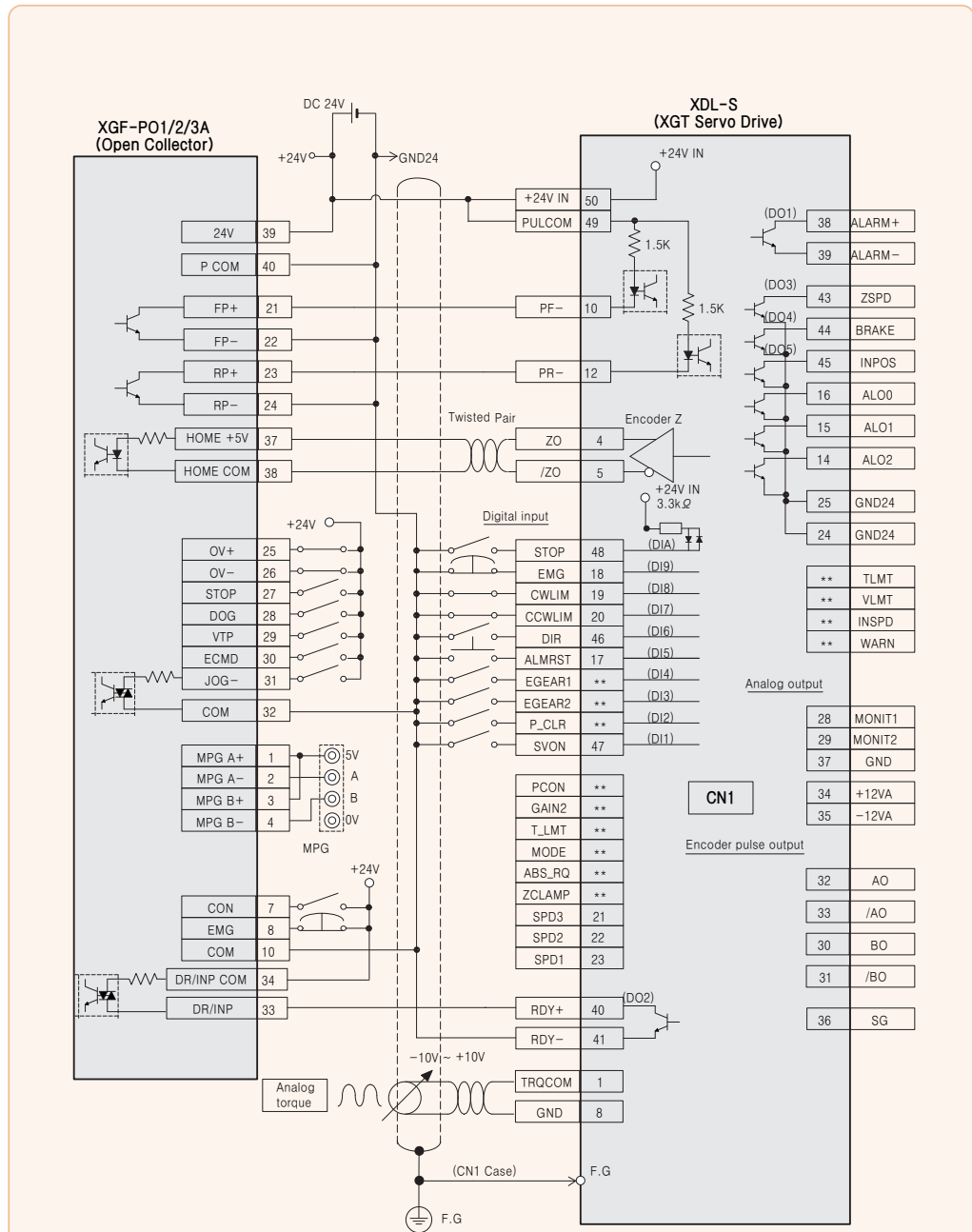

Note1) Input signals DI1 to DIA and output signals DO1 to DO5 are default signals allocated by the factory.
 Note2) These are non-allocated signals. You can change their allocation by setting parameters. For more information, refer to XDL/XML servo manual.

XGF-PD1/2/3A (Line Driver)

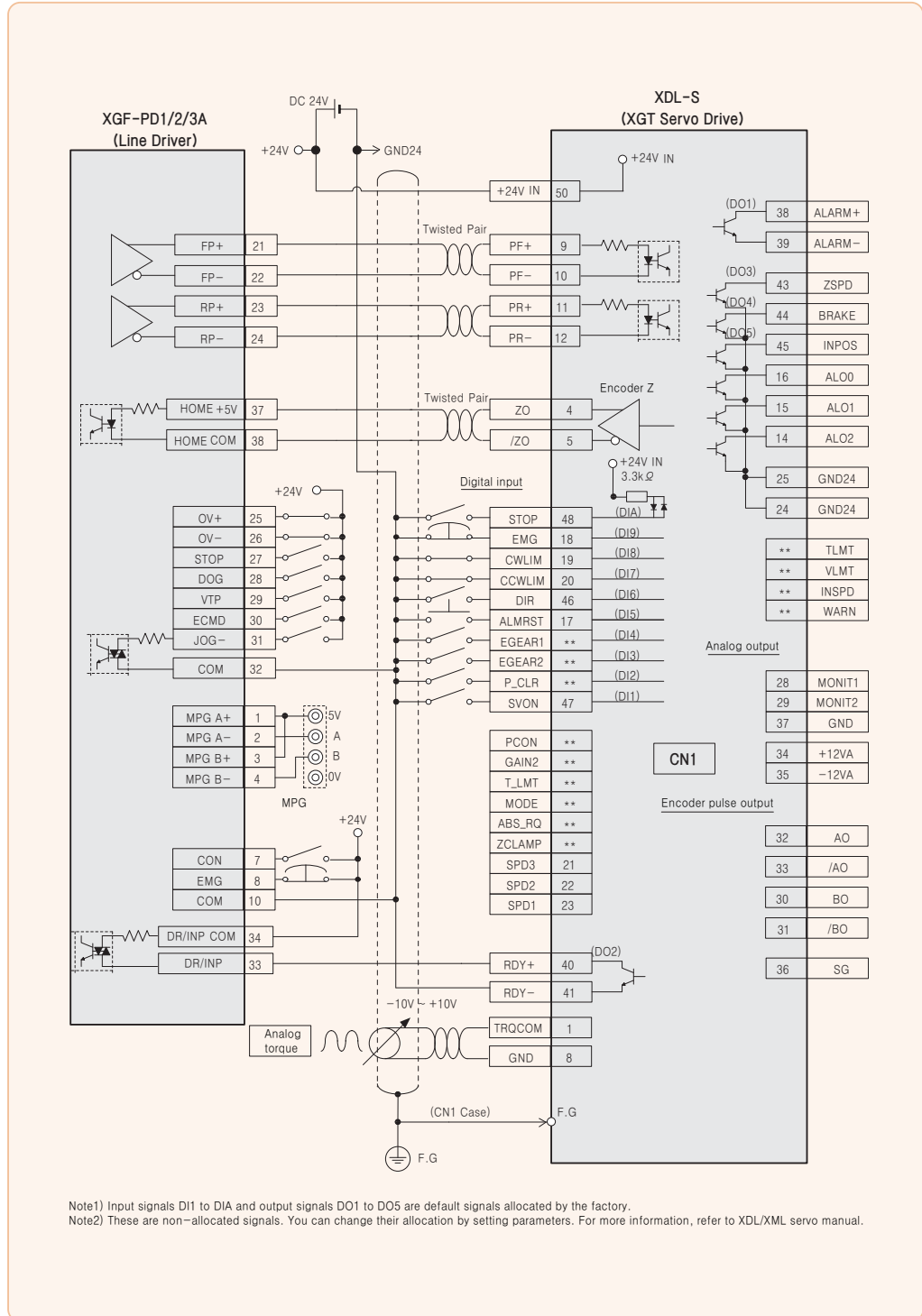

XGF-PO1/2/3/4H (Open Collector)

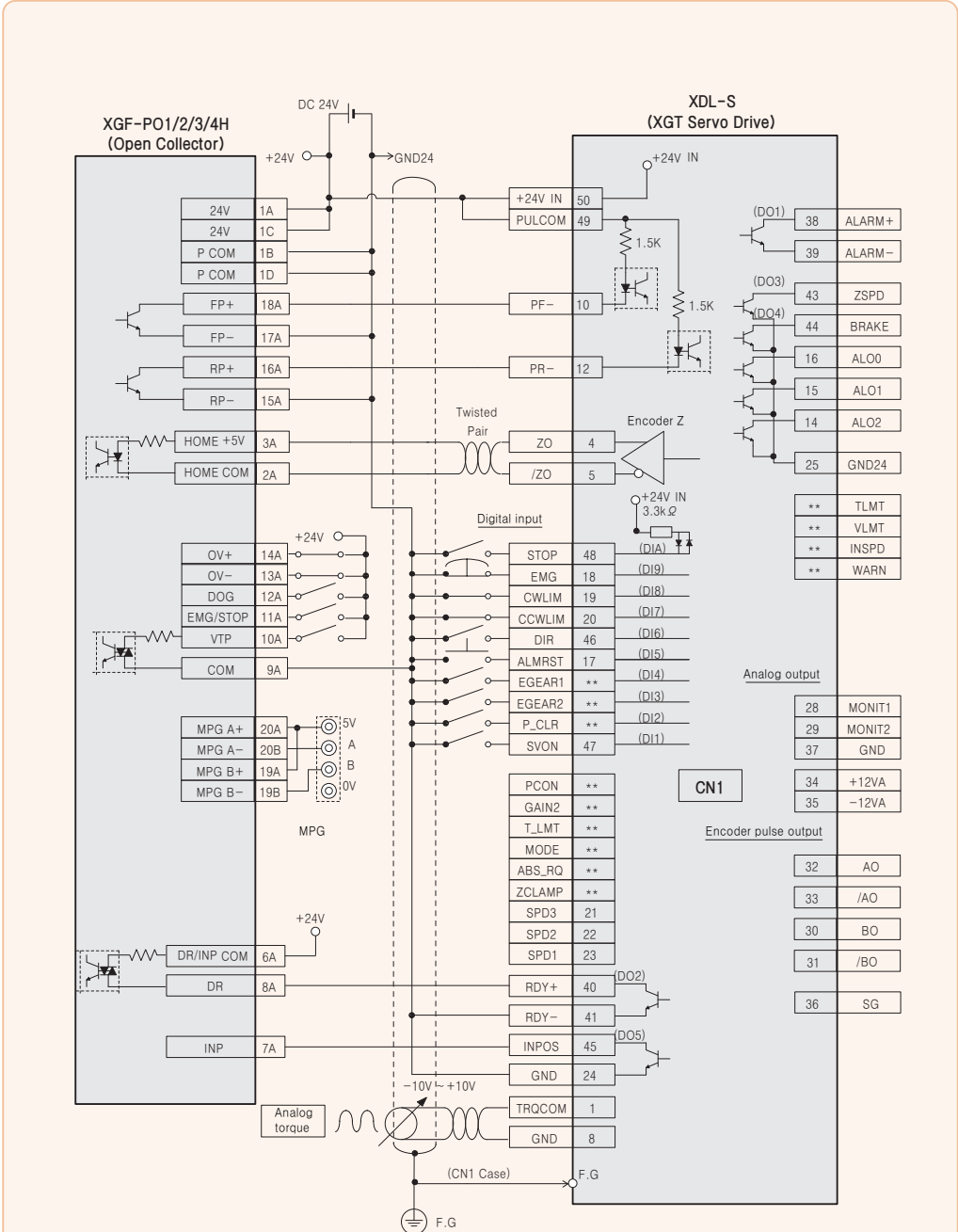

Note1) Input signals DI1 to DIA and output signals DO1 to DO5 are default signals allocated by the factory.
 Note2) These are non-allocated signals. You can change their allocation by setting parameters. For more information, refer to XDL/XML servo manual.

XGF-PD1/2/3/4H (Line Driver)

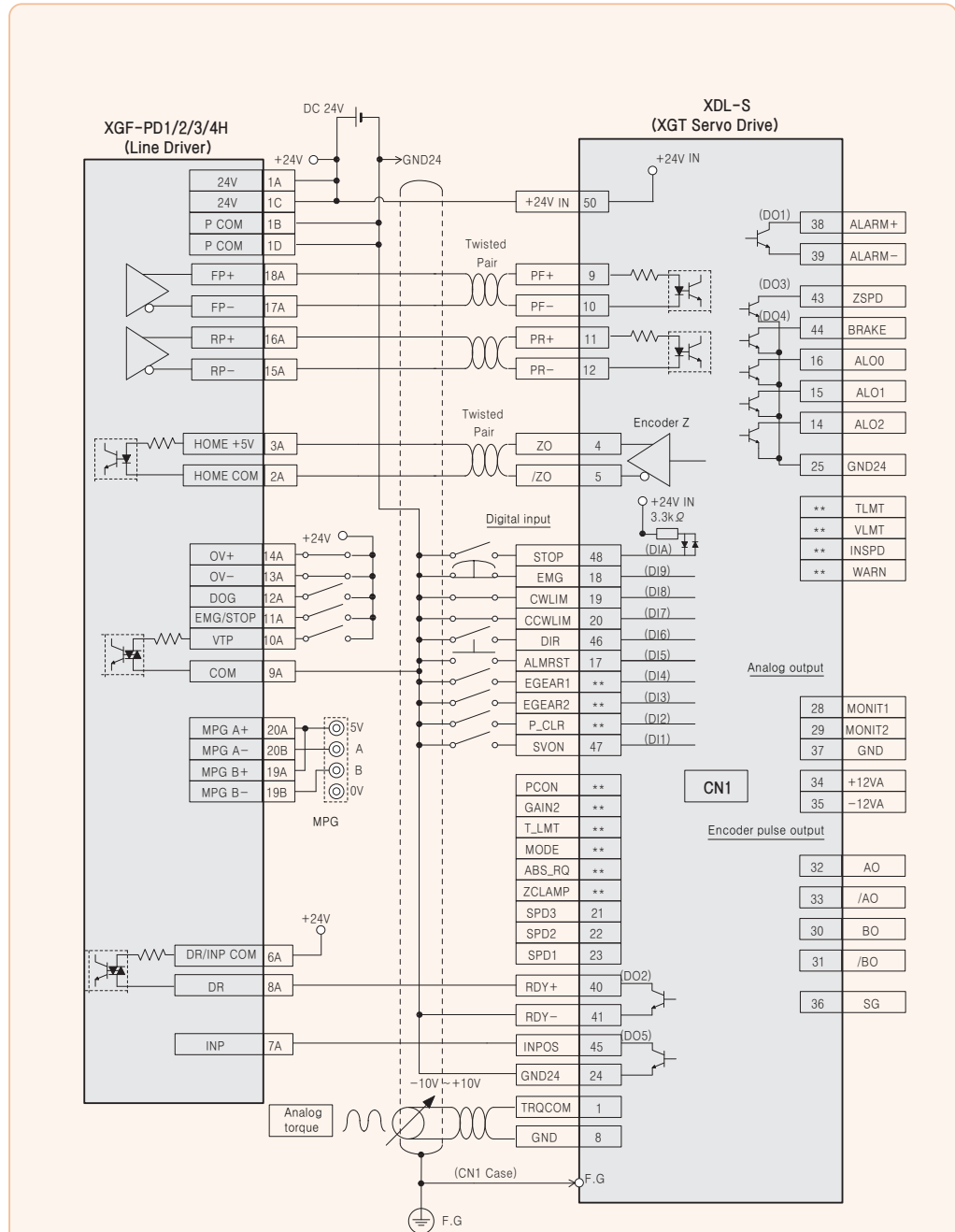

Note1) Input signals DI1 to DIA and output signals DO1 to DO5 are default signals allocated by the factory.

Note2) These are non-allocated signals. You can change their allocation by setting parameters. For more information, refer to XDL/XML servo manual.

XBF-PD02A(Line Driver)

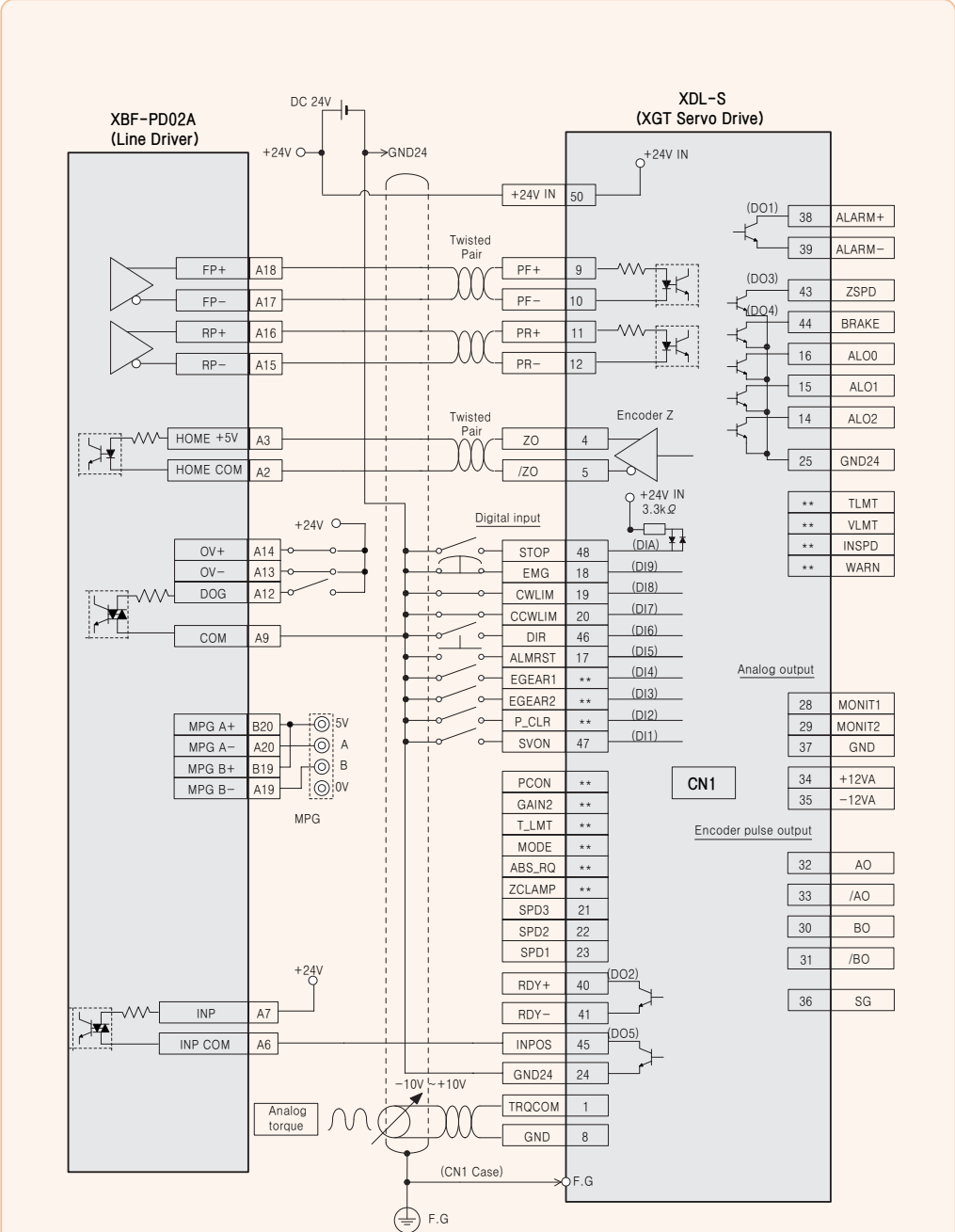

Note1) Input signals D11 to DIA and output signals DO1 to DO5 are default signals allocated by the factory.
 Note2) These are non-allocated signals. You can change their allocation by setting parameters. For more information, refer to XDL/XML servo manual.

XBM-DN**S(Open Collector)

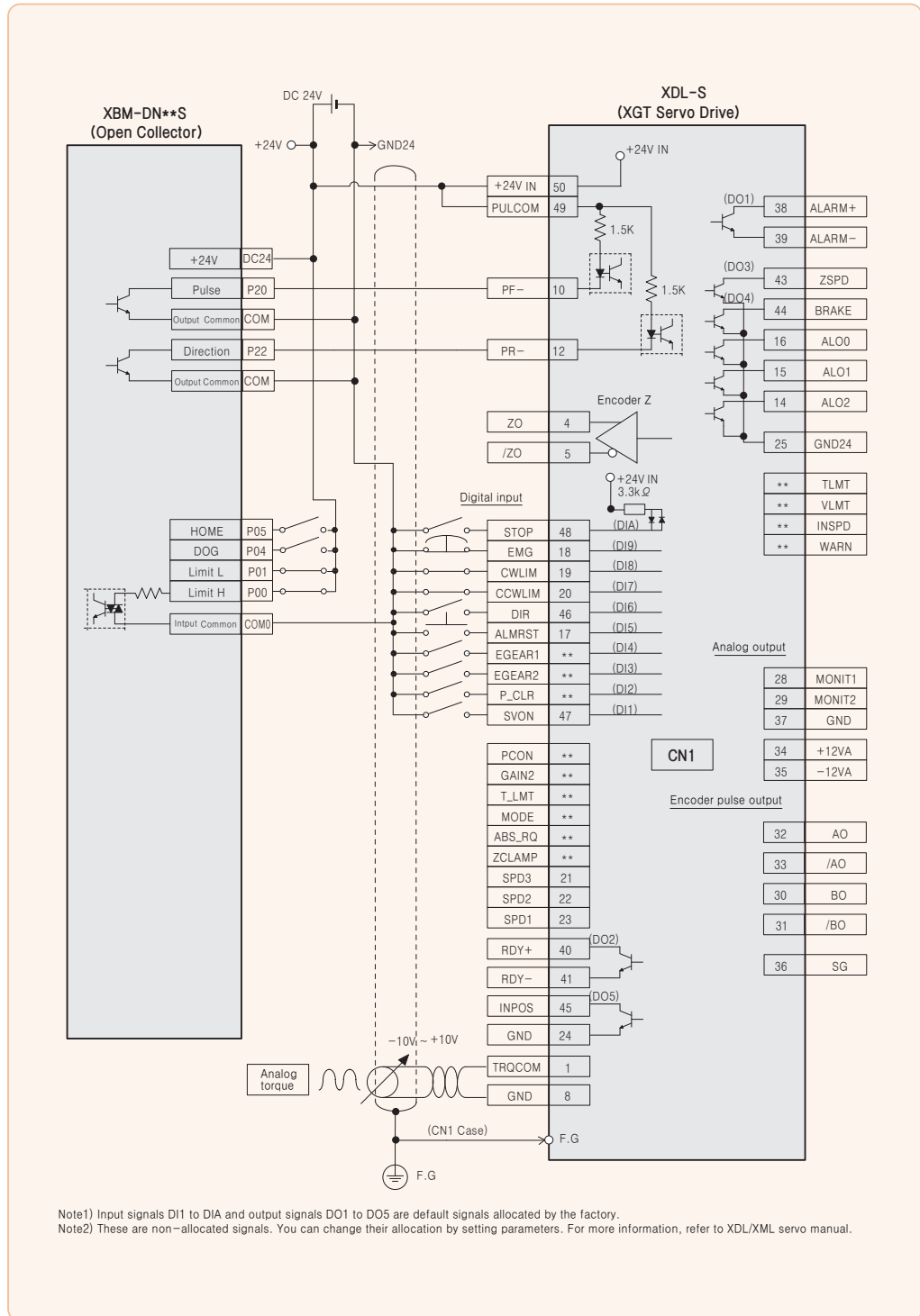

Note1) Input signals DI1 to DIA and output signals DO1 to DO5 are default signals allocated by the factory.
 Note2) These are non-allocated signals. You can change their allocation by setting parameters. For more information, refer to XDL/XML servo manual.

XBC/XEC-DN**H(Open Collector)

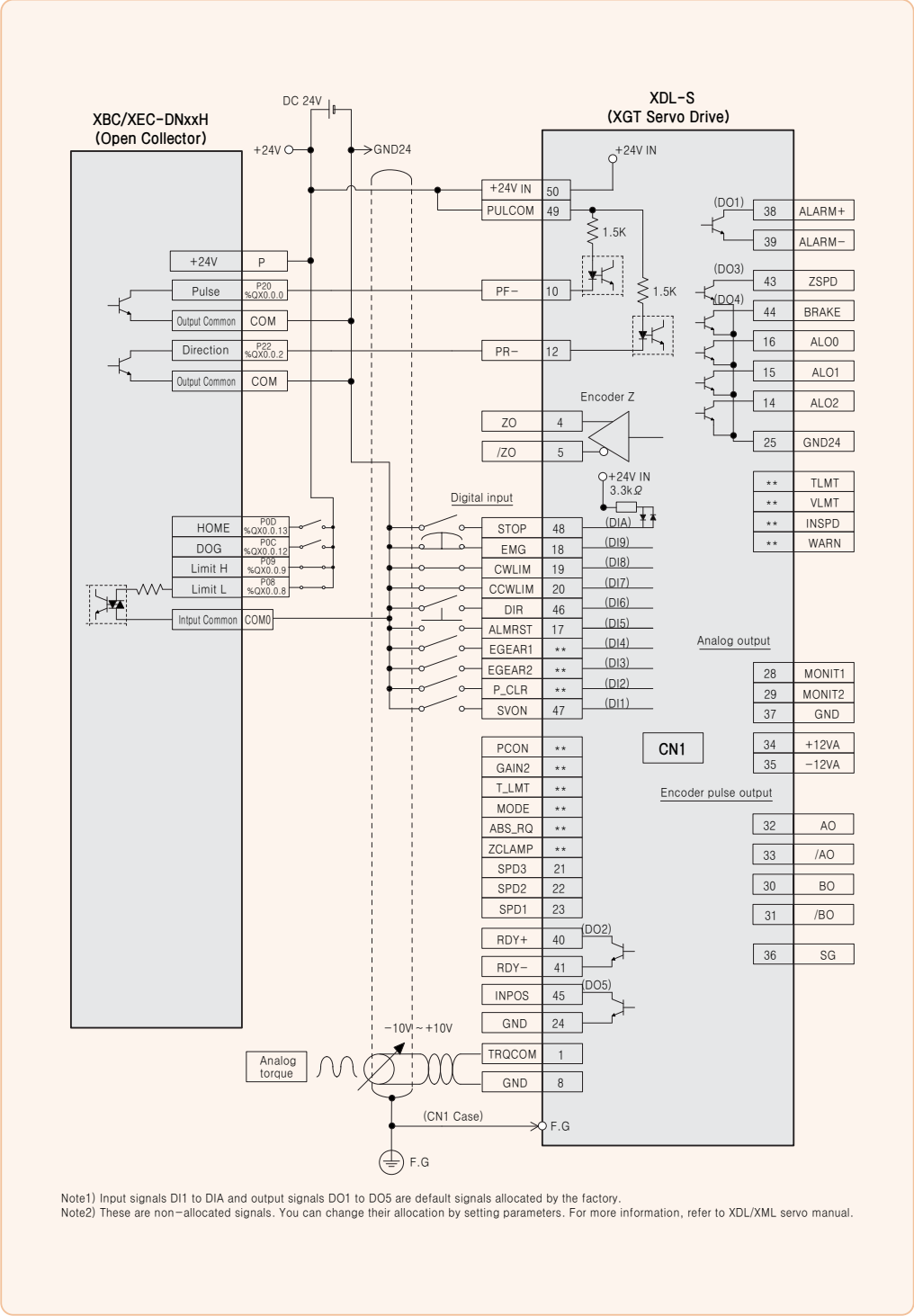

XGF-M32E

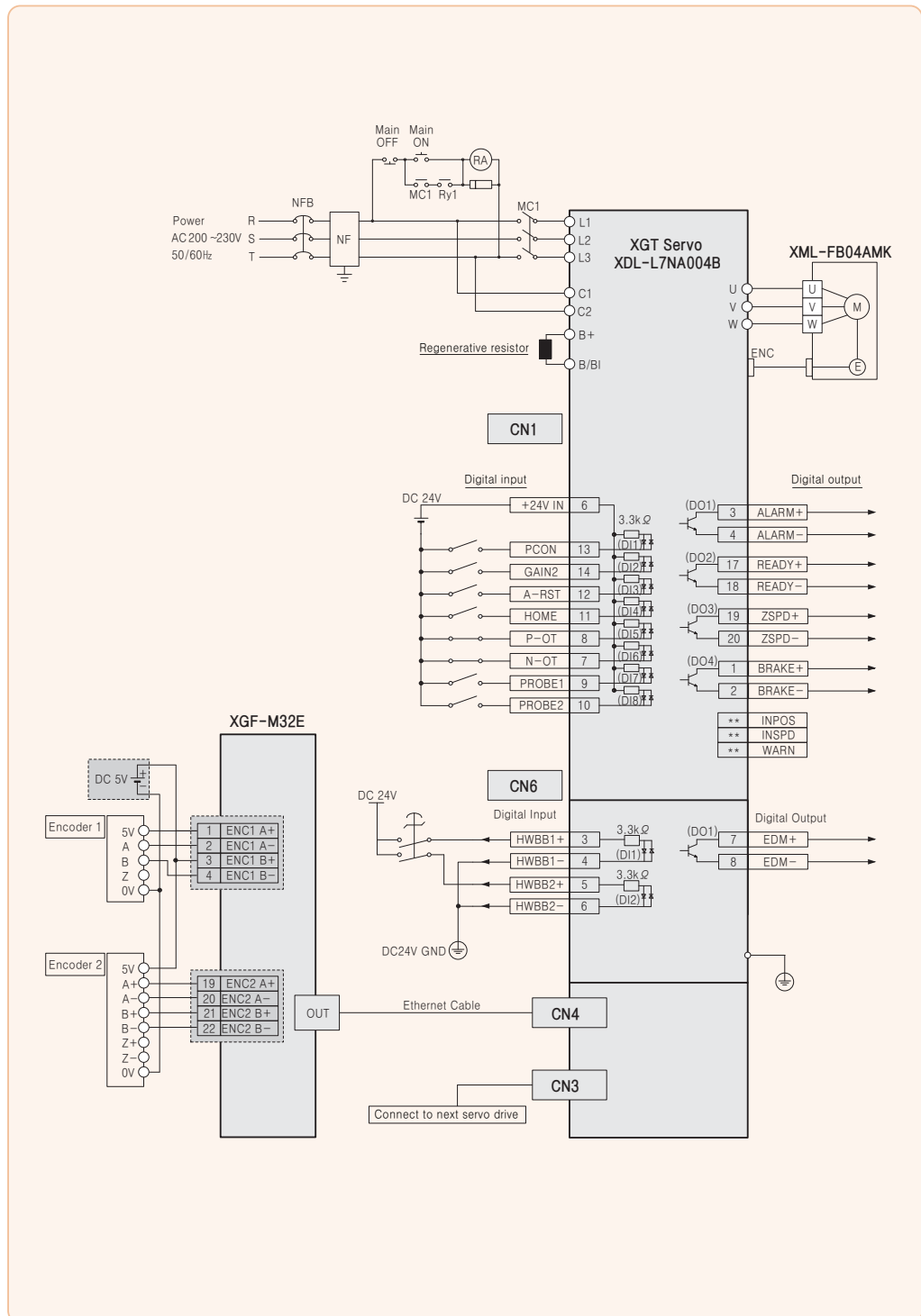

XGF-PN8B

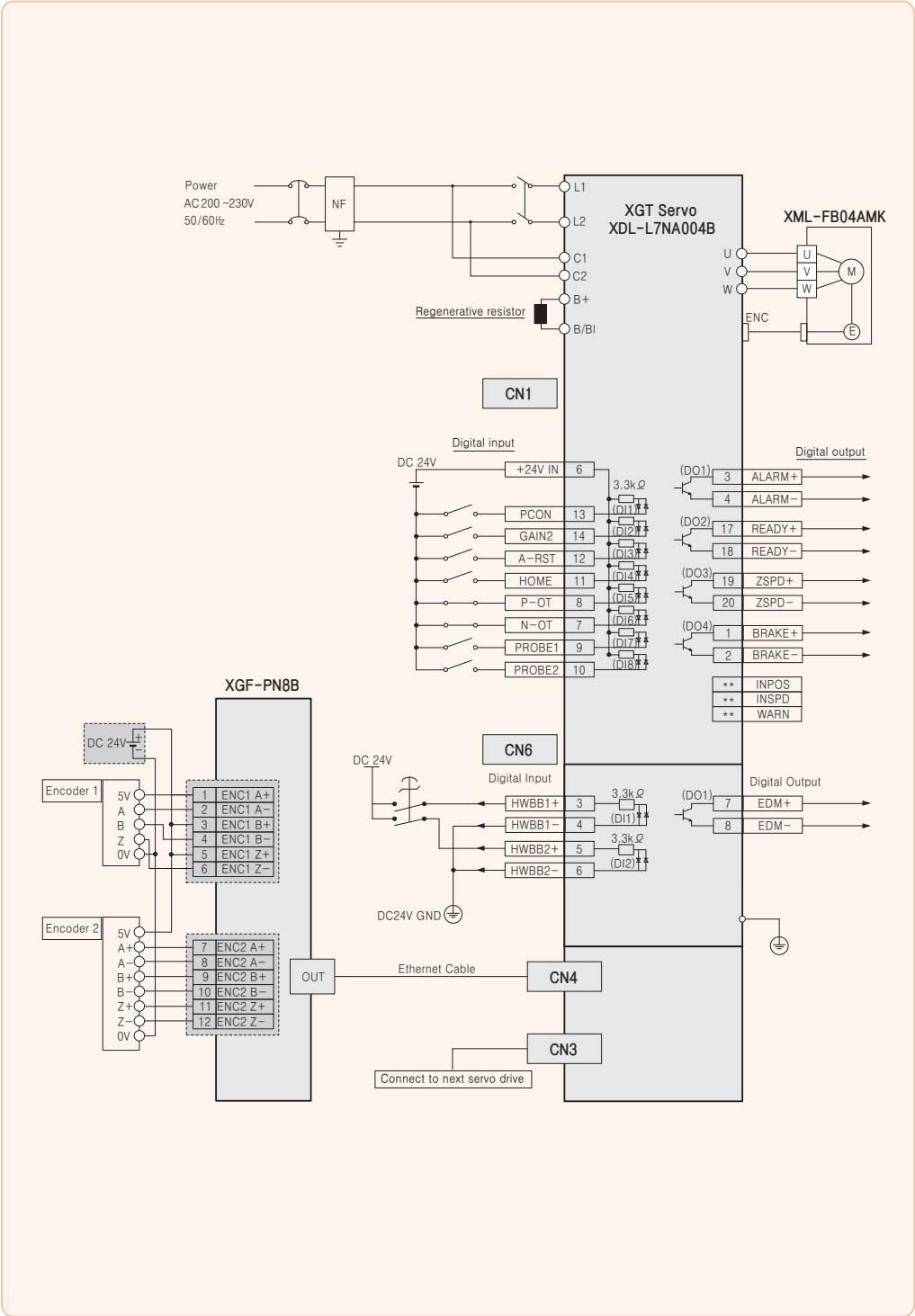

A large, empty rectangular area with a light beige background and a thin red border, intended for writing a memo.

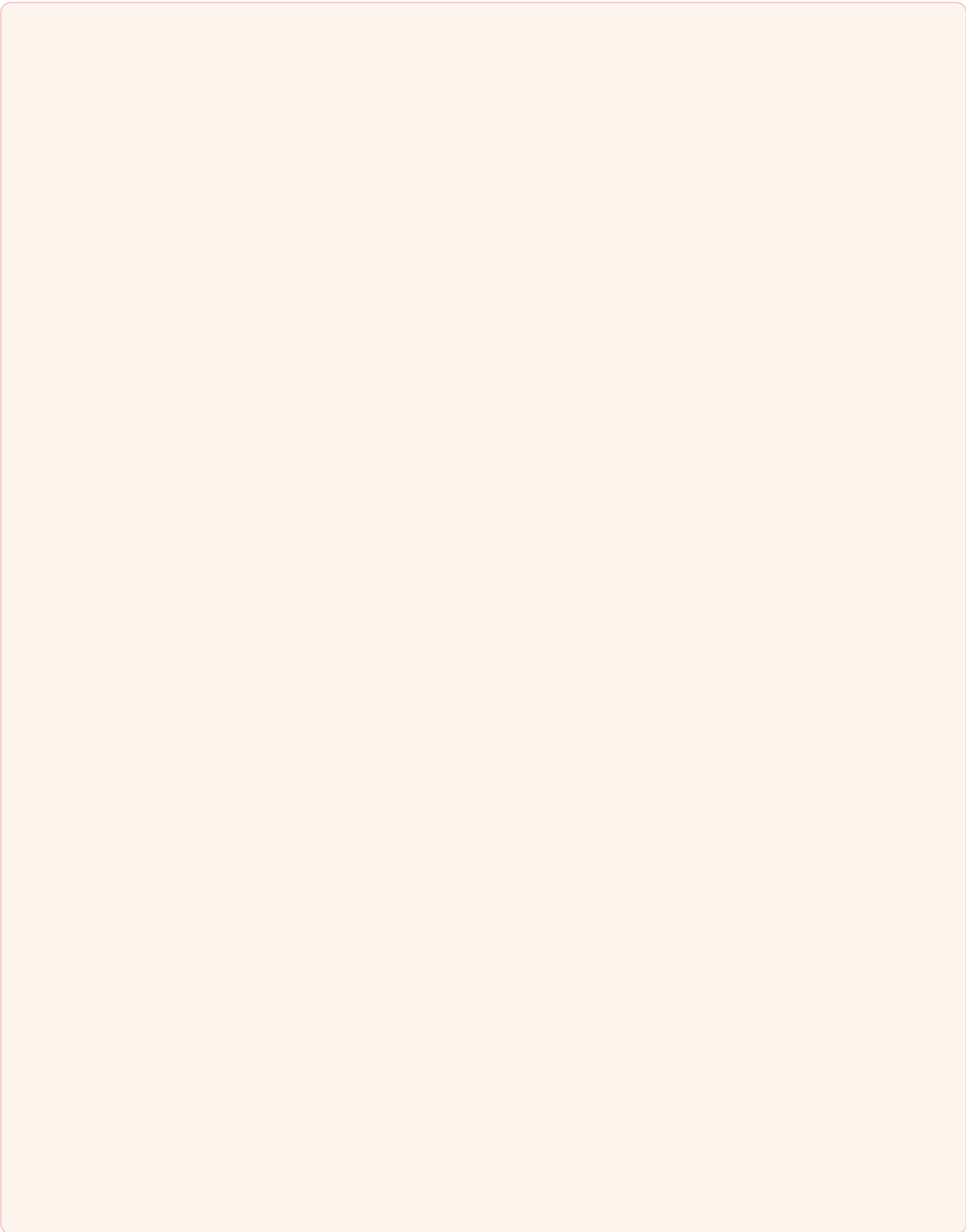

Worldwide Network

Head Office and Domestic Factories (Cheongju, Cheonan, Busan)

Domestic Factories

- **Head Office**
LS Tower, 127, LS-ro, Dongan-gu, Anyang-si, Gyeonggi-Do, 431-848, Korea
Tel : 82-2-2034-4870 Fax : 82-2-2034-3660-7021
- **Cheongju Factory**
1 Songjeong-dong, Cheongju-si, Chungbuk-do, 361-720, Korea
Tel : 82-43-261-6114 Fax : 82-43-261-6602
- **Cheonan Factory**
181 Samseong-ri, Mokcheon-myeon, Cheonan-si Chungnam-do, 330-840 Korea
Tel : 82-41-550-8114 Fax : 82-41-566-8408
- **Busan Factory**
1-19 Block Hwajeon-dong, Gangseo-gu, Busan, 618-280, Korea
Tel : 82-51-795-6114 Fax : 82-51-795-6169

Overseas Factories

- **Wuxi Factory, CHINA**
102-A. National High & New Tech Industrial Development Area, Wuxi. Jiangsu. 214028. P.R. China
Tel : 86-510-8534-6666 Fax : 86-510-8534-4078
- **Dalian Factory, CHINA**
No. 15. Liaohexi 3-Road. Economic and Technical Development zone. Dalian 116600. China
Tel : 86-411-273-7777 Fax : 86-411-8730-7560
- **Hanoi Factory, VIETNAM**
Room 1311, 13th Floor, M3-M4 Building 91 Nguyen Chi Thanh street, Hanoi, Vietnam.
Tel : 84-4-6275-8055 Fax : 84-4-6275-8056

R&D Center

- **Advanced Technology R&D Center**
533 Hogye-dong, Dongan-gu, Anyang-si, Gyeonggi-do, 431-749, Korea
Tel : 82-31-450-7114
- **Electro Technology R&D Center**
1 Songjeong-dong, Cheongju-si, Chungcheongbuk-do, 361-720, Korea
Tel : 82-43-261-6114
- **Automation R&D Center**
181 Samseong-ri, Mokcheon-myeon, Cheonan-si, Chungcheongnam-do, 330-840, Korea
Tel : 82-41-550-8272
- **Power Testing & Technology Institute**
1 Songjeong-dong, Cheongju-si, Chungcheongbuk-do, 361-720, Korea
Tel : 82-43-261-6114



Cheongju Factory



Wuxi Factory (China)



Cheonan Factory



Dalian Factory (China)



Busan Factory



Hanoi Factory (Vietnam)

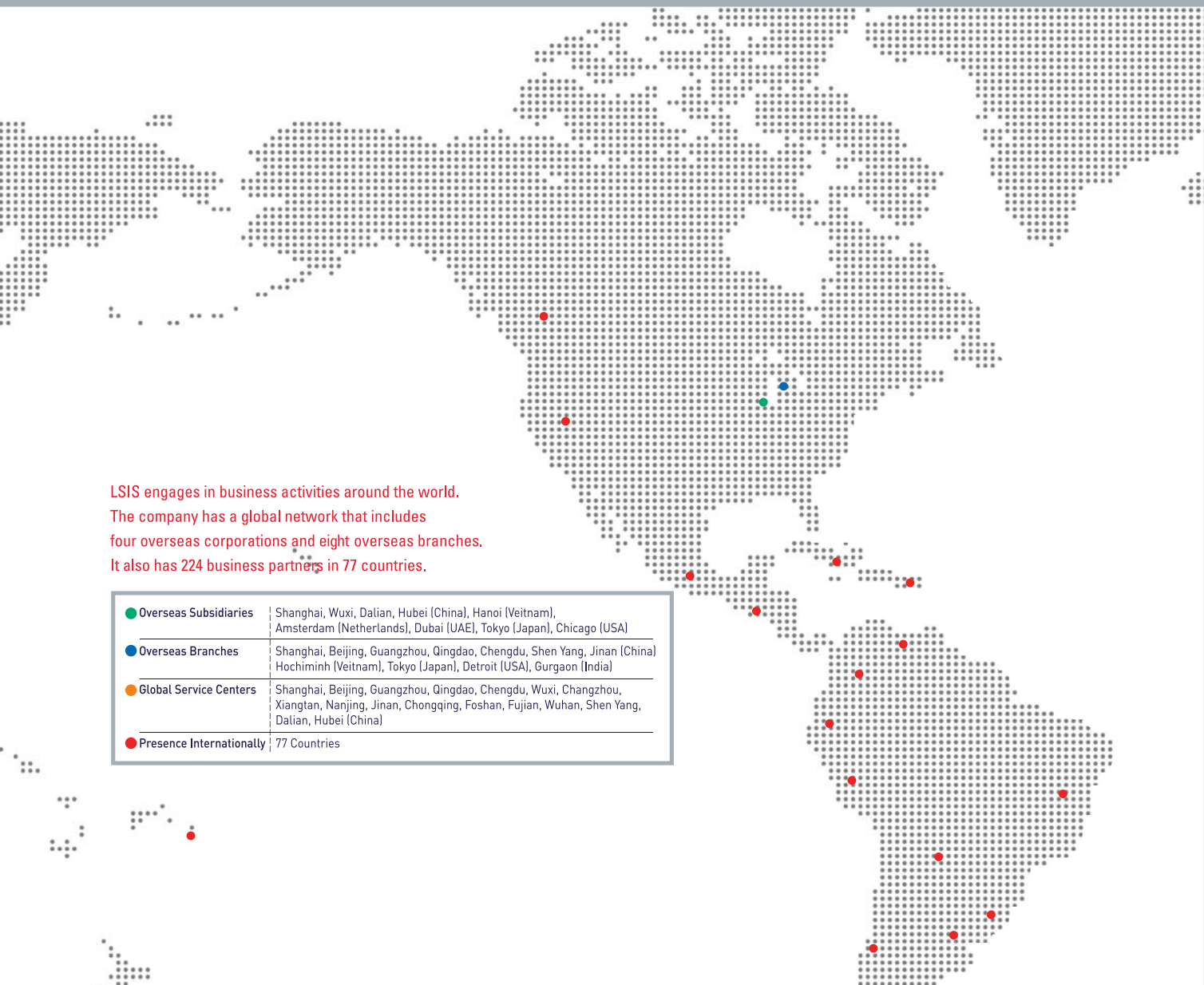

LSIS engages in business activities around the world.
 The company has a global network that includes
 four overseas corporations and eight overseas branches.
 It also has 224 business partners in 77 countries.

● Overseas Subsidiaries	Shanghai, Wuxi, Dalian, Hubei (China), Hanoi (Vietnam), Amsterdam (Netherlands), Dubai (UAE), Tokyo (Japan), Chicago (USA)
● Overseas Branches	Shanghai, Beijing, Guangzhou, Qingdao, Chengdu, Shen Yang, Jinan (China) Hochiminh (Vietnam), Tokyo (Japan), Detroit (USA), Gurgaon (India)
● Global Service Centers	Shanghai, Beijing, Guangzhou, Qingdao, Chengdu, Wuxi, Changzhou, Xiangtan, Nanjing, Jinan, Chongqing, Foshan, Fujian, Wuhan, Shen Yang, Dalian, Hubei (China)
● Presence Internationally	77 Countries

Overseas Subsidiaries

- LSIS(Shanghai) Co., Ltd. / CHINA
32nd Room 1-4, 32/F, Great Wall Building, No.3000 North Zhongshan Road, Putuo District, Shanghai, P.R. China
Tel : 86-21-5237-9977(609) Fax : 86-21-5237-7189
- LSIS(Dalian) Co., Ltd. / CHINA
No. 15, Liaohexi 3-Road, Economic and Technical Development zone, Dalian, P.R. China
Tel : 86-411-8731-7542 Fax : 86-411-8730-7560 E-Mail : dskim@lsis.com
- LSIS(Wuxi) Co., Ltd. / CHINA
102-A, National High & New Tech Industrial Development Area, Wuxi, Jiangsu, P.R. China
Tel : 86-510-8534-6666 Fax : 86-510-8534-4078 E-Mail : sojin@lsis.com
- LS Hukai Electric(Hubei) Co., Ltd. / CHINA
No. 100, Tanjahe Road, Dianjun District, Yichang City, Hubei Province, P.R. China
Tel : 86-717-667-7536 Fax : 86-717-667-7222 E-Mail : jaewoongh@lsis.com
- LS-VINA Industrial Systems Co., Ltd. / VIETNAM
Room 1311, 13th, M3-M4 Building 91 Nguyen Chi Thanh street, Hanoi, Vietnam
Tel : 84-4-6275-8055 Fax : 86-21-5237-7189
- LSIS[ME] FZE / U.A.E.
LOB 19-205, JAFZA View Tower, Jebel Ali Free Zone, Dubai, United Arab Emirates
Tel : 971-4-886-5360 Fax : 971-4-886-5361 E-Mail : shunlee@lsis.com
- LSIS Europe B.V. / NETHERLANDS
1st. Floor, Tupolevlaan 48, 1119NZ, Schiphol-Rijk, The Netherlands
Tel : 31-20-654-1420 Fax : 31-20-654-1429 E-Mail : junshickp@lsis.com
- LSIS Japan Co., Ltd. / JAPAN
16th, Higashi-Kan, Akasaka Twin Tower, 2-17-22, Akasaka, Minato-ku, Tokyo, Japan
Tel : 81-3-3582-9128 Fax : 81-3-3582-2667 E-Mail : jschuna@lsis.com
- LSIS USA Inc. / U.S.A.
2000 Millbrook Drive, Lincolnshire, Chicago, IL 60069, United States of America
Tel : 847-941-8240 Fax : 847-941-8259

Overseas Branches

- LSIS Shanghai Office / CHINA
Room E-G, 12th, Huamin Empire Plaza, No.726, West Yan'an Road, Shanghai, P.R. China
Tel : 86-21-5237-9977(702) Fax : 86-21-5237-7189
- LSIS Beijing Office / CHINA
Room 2306, Building B Landgent Center, No.24 Middle Road, East 3rd Ring Road, Chaoyang District, Beijing, P.R. China
Tel : 86-10-5761-3127 Fax : 86-10-5761-3128 E-Mail : htroh@lsis.com
- LSIS Guangzhou Office / CHINA
Room 1403, 14th, New Poly Tower, 2 Zhongshan Liu Road, Guangzhou, P.R. China
Tel : 86-20-8326-6784 Fax : 86-20-8326-6287 E-Mail : sojhtroh@lsis.com
- LSIS Qingdao Office / CHINA
Room 2001, Galaxy Building, 29 ShanDong Road, ShiNan District, QingDao, ShanDong, P.R. China
Tel : 86-532-8501-6058 Fax : 86-532-8501-6057 E-Mail : htroh@lsis.com
- LSIS Chengdu Office / CHINA
Room 1710, 17/F Huamin Empire Plaza, NO.1 Fuxin Road, Chengdu, P.R. China
Tel : 86-28-8670-3201 Fax : 86-28-8670-3203 E-Mail : yangcf@lsis.com
- LSIS ShenYang Office / CHINA
Room 803, Hongyuan Building, 52 South Nanjing Road, Heping District, Shenyang, P.R. China
Tel : 86-24-2321-9050 Fax : 86-24-8386-7210 E-Mail : yangcf@lsis.com
- LSIS Jinan Office / CHINA
Room 417, Chuangzhan Center, No. 201, Shanda Road, Lixia District, Jinan, Shandong, P.R. China
Tel : 86-531-8263-8026 Fax : 86-531-8263-8027 E-Mail : yangcf@lsis.com
- LSIS Tokyo Office / JAPAN
16th, Higashi-Kan, Akasaka Twin Tower, 2-17-22, Akasaka, Minato-ku, Tokyo, Japan
Tel : 81-3-3582-9128 Fax : 81-3-3582-2667
- LS-VINA Industrial Systems Hochiminh Office / VIETNAM
4th, Yoco Building, 41 Nguyen Thi Minh Khai Street, Hochiminh City, Vietnam
Tel : 84-8-3822-7941 Fax : 81-84-8-3822-7942 E-Mail : sjbaik@lsis.com
- LSIS Detroit Office / U.S.A.
5700 Crooks Rd, Suite 211, Troy, MI 48098, United States of America
Tel : 1-248-792-2637-8 Fax : 1-248-792-2642t E-Mail : sylee@lsis.com
- LSIS Gurgaon Office / INDIA
109 First Floor, Park Central, Sector-30, Gurgaon- 122 002, Haryana, India
Tel : +0091-124-493-0070 Fax : 91-1244-930-066 E-Mail : hwyim@lsis.com



Safety Instructions

- For your safety, please read user's manual thoroughly before operating.
- Contact the nearest authorized service facility for examination, repair, or adjustment.
- Please contact qualified service technician when you need maintenance. Do not disassemble or repair by yourself !
- Any maintenance and inspection shall be performed by the personnel having expertise concerned.

LSIS Co., Ltd.

©2008. LSIS Co., Ltd. All Rights Reserved.

HEAD OFFICE

LS Tower, 127, LS-ro, Dongan-gu, Anyang-si, Gyeonggi-Do, 431-848, Korea

■ Southeast Asia	+82-2-2034-4888	cshwang@lsis.com (Charles Hwang)
■ Europe	+82-2-2034-4676	sukyong@lsis.com (Brian Choi)
■ Turkey/Israel/CIS	+82-2-2034-4879	dkimc@lsis.com (Daniel Kim)
■ Oceania	+82-2-2034-4394	kacho@lsis.com (Kendra Cho)
■ North/Latin America	+82-2-2034-4286	hkchung@lsis.com (Hank Raul Chung)
■ Southwest Asia/Africa	+82-2-2034-4467	myleed@lsis.com (Henry Lee)
■ Middle East	+971-4-886-5360	khchoi1@lsis.com (Lambert Choi)

Overseas Subsidiaries

- **LSIS(Shanghai) Co., Ltd. /CHINA**
32nd Room 1-4, 32/F, Great Wall Building, No.3000 North Zhongshan Road, Putuo District, Shanghai, P.R. China
Tel : 86-21-5237-9977(609) Fax : 86-21-5237-7189
- **LSIS(Dalian) Co., Ltd. /CHINA**
No. 15, Liaohexi 3-Road, Economic and Technical Development zone, Dalian, P.R. China
Tel : 86-411-8731-7542 Fax : 86-411-8730-7560 E-Mail : dskim@lsis.com
- **LSIS(Wuxi) Co., Ltd./CHINA**
102-A, National High & New Tech Industrial Development Area, Wuxi, Jiangsu, P.R. China
Tel : 86-510-8534-6666 Fax : 86-510-8534-4078 E-Mail : sojin@lsis.com
- **LS Hukai Electric(Hubei) Co., Ltd./CHINA**
No. 100, Tanjiahe Road, Dianjun District, Yichang City, Hubei Province, P.R. China
Tel : 86-717-667-7536 Fax : 86-717-667-7222 E-Mail : jaewoongh@lsis.com
- **LS-VINA Industrial Systems Co., Ltd./VIETNAM**
Room 1311, 13th, M3-M4 Building 91 Nguyen Chi Thanh street, Hanoi, Vietnam
Tel : 84-4-6275-8055 Fax : 86-21-5237-7189
- **LSIS(ME) FZE/U.A.E.**
LOB 19-205, JAFZA View Tower, Jebel Ali Free Zone, Dubai, United Arab Emirates
Tel : 971-4-886-5360 Fax : 971-4-886-5361 E-Mail : shunlee@lsis.com
- **LSIS Europe B.V./NETHERLANDS**
1st. Floor, Tupolevlaan 48, 1119NZ, Schiphol-Rijk, The Netherlands
Tel : 31-20-654-1420 Fax : 31-20-654-1429 E-Mail : htha@lsis.com
- **LSIS Japan Co., Ltd./JAPAN**
16th, Higashi-Kan, Akasaka Twin Tower, 2-17-22, Akasaka, Minato-ku, Tokyo, Japan
Tel : 81-3-3582-9128 Fax : 81-3-3582-2667 E-Mail : jschuna@lsis.com
- **LSIS USA Inc./U.S.A.**
2000 Millbrook Drive, Lincolnshire, Chicago, IL 60069, United States of America
Tel : 847-941-8240 Fax : 847-941-8259 E-Mail : ybleeb@lsis.com

Overseas Branches

- **LSIS Shanghai Office/CHINA**
Room E-6, 12th, Huamin Empire Plaza, No.726, West Yan'an Road, Shanghai, P.R. China
Tel : 86-21-5237-9977(702) Fax : 86-21-5237-7189
- **LSIS Beijing Office/CHINA**
Room 2306, Building B Landgent Center, No.24 Middle Road, East 3rd Ring Road, Chaoyang District, Beijing, P.R. China
Tel : 86-10-5761-3127 Fax : 86-10-5761-3128 E-Mail : htroh@lsis.com
- **LSIS Guangzhou Office/CHINA**
Room 1403, 14th, New Poly Tower, 2 Zhongshan Liu Road, Guangzhou, P.R. China
Tel : 86-20-8326-6784 Fax : 86-20-8326-6287 E-Mail : sojhtroh@lsis.com
- **LSIS Qingdao Office/CHINA**
Room 2001, Galaxy Building, 29 ShanDong Road, ShiNan District, QingDao, ShanDong, P.R. China
Tel : 86-532-8501-6058 Fax : 86-532-8501-6057 E-Mail : htroh@lsis.com
- **LSIS Chengdu Office/CHINA**
Room1710, 17/F Huamin Empire Plaza, NO.1 Fuxin Road, Chengdu, P.R. China
Tel : 86-28-8670-3201 Fax : 86-28-8670-3203 E-Mail : yangcf@lsis.com
- **LSIS ShenYang Office/CHINA**
Room 803, Hongyuan Building, 52 South Nanjing Road, Heping District, Shenyang, P.R. China
Tel : 86-24-2321-9050 Fax : 86-24 -8386-7210 E-Mail : yangcf@lsis.com
- **LSIS Jinan Office/CHINA**
Room 417, Chuangzhan Center, No. 201, Shanda Road, Lixia District, Jinan, Shandong, P. R. China
Tel : 86-531-8263-8026 Fax : 86-531-8263-8027 E-Mail : yangcf@lsis.com
- **LSIS Tokyo Office/JAPAN**
16th, Higashi-Kan, Akasaka Twin Tower, 2-17-22, Akasaka, Minato-ku, Tokyo, Japan
Tel : 81-3-3582-9128 Fax : 81-3-3582-2667
- **LS-VINA Industrial Systems Hochiminh Office/VIETNAM**
4th, Yoco Building, 41 Nguyen Thi Minh Khai Street, Hochiminh City, Vietnam
Tel : 84-8-3822-7941 Fax : 81-84-8-3822-7942 E-Mail : sjbaik@lsis.com
- **LSIS Detroit Office/U.S.A.**
5700 Crooks Rd, Suite 211, Troy, MI 48098, United States of America
Tel : 1-248-792-2637-8 Fax : 1-248-792-2642 E-Mail : sylee@lsis.com
- **LSIS Gurgaon Office/INDIA**
109 First Floor, Park Central, Sector-30, Gurgaon- 122 002, Haryana, India
Tel : +0091-124-493-0070 Fax : 91-1244-930-066 E-Mail : hwyim@lsis.com

Specifications in this catalog are subject to change without notice due to continuous product development and improvement.