

Driving the future

Customize the new future

F100 series Compact Inverter



Customize the new future

LS 021-88464139
09106611367
WWW.LSKALA.COM

HiTEK-F100 series

-Add:No. 9, 26th Street, Eastern New Area, Wenling, Zhejiang, China E

Driving the future



ABOUT US

Zhejiang New HiTEK Electric Co., Ltd, also called Folinn for short, was founded in 1994. Located at Wenling, the youngest coastal city in China, and well-known manufacturing base in Yangtze River Delta

We are specialized in manufacturing inverter, our market share has been in the forefront of the industry, is well-known inverter manufacturer who engaged in the development, manufacturing and marketing of industrial automation control products in China.

We have 270 patented technologies and 21 software copyrights. The total building area of our factory is 35,000 square meters. And we have established three R&D centers in Taizhou, Hangzhou and Germany, sales network and after-sales service agencies have been throughout the main provinces and autonomous regions, exported to Europe and the United States, southeast Asia, the Middle East and other countries.

Folinn always adheres to the service concept of quality and customer first. Depends on the advantages of technology research and marketing channels, Folinn more actively expands its product line, and improves the core competitiveness in the market continuously, and provides high-quality electrical products and personalized solutions for electric power, new energy, machinery manufacturing and other fields.

Driving Follow Heart, Winning The Future!

CONTENTS

Appearance Introduction	05
Panel Introduction and Technical Specifications	06
Product Features	08
Application	15
Wiring	16
Size and Model	17



APPEARANCE INTRODUCTION

Compact & Flexible

F100 Series Compact Inverter

Based on the industrial application demand of high stability, small size and easy debugging,

HiTEK has developed a new generation of compact inverter.

Support industry customization, widely used in woodworking machinery, fans and water pump, food filling, ceramic machinery, textile machinery and other equipment



PRODUCT APPEARANCE INTRODUCTION

Compact design, Customized interface



Easy detachable fan design
easy to replace, easy to clean, long life



Function Card
Press to remove it easily and can replace it with customized function card

⚠ Plug and unplug with power is strictly prohibited



Abundant display
LED keypad, LCD keypad



External operation panel
parameter copy, fault diagnosis, operation optimization, cloud connection



Independent air duct
Reliable heat dissipation high protection level



Customized terminal
Customization cost rationalization according to industry characteristics and customer demands



European terminal
no need special tools, easy connection, save time

PANEL INTRODUCTION

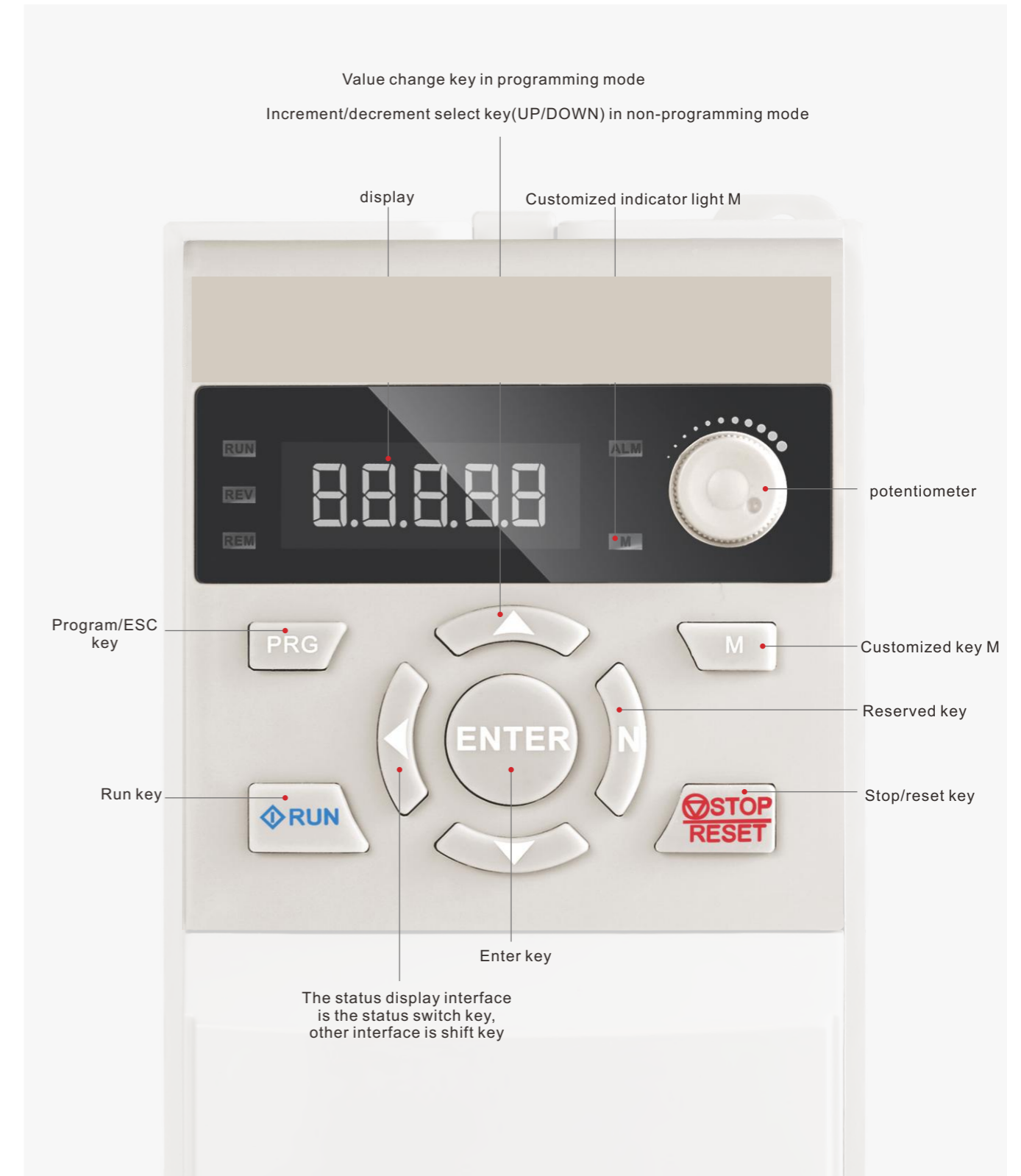

TECHNICAL SPECIFICATIONS

	Item	Description
Input	Rated voltage, frequency	three phase: 380V~440V,50Hz/60Hz; single phase: 200V~240V,50Hz/60Hz
	voltage operating range	three phase: 380V~440V,50Hz/60Hz single phase: 200V~240V,50Hz/60Hz Voltage unbalance rate:<3%; frequency:±5%
Output	voltage	0-rated input voltage
	frequency	0Hz~1000Hz
	overload capacity	150% rated current 60s, 180% rated current 2s
main control performance	control mode	V/F/SVC
	modulation mode	Space vector PWM modulation
	motor type	asynchronous motor, synchronous motor, single motor (Please consult the manufacturer when using)
	start torque	0.5Hz/150% rated torque
	speed adjusting range	1:100(speed sensorless)
	frequency accuracy	digital setting: max. frequency ±0.01%; analog setting: max. frequency ±1%
	frequency resolution	digital setting: max. frequency ±0.01%; analog setting: max. frequency ±1%
	acceleration and deceleration curve	line/S-curve
	current limiting	Automatic current limitation during operation to prevent frequent over current fault tripping
	instant power down	Support instant stop non-stop, 1:100(speed sensorless)
operation function	command source	keypad, terminal, communication
	setting value source	digital, analog, multi-step speed, communication
	PID	support main setting+PID
protection function	over current, over voltage, under voltage, over heat, over load, phase loss, earth leakage, output short circuit protection, etc	
	communication	MODBUS RTU
Operation panel	digital tube display	output frequency, output current, output voltage, bus voltage, dispalyed value 1, displayed value 2, current alarm, current fault
	external keypad	support
Environment	applicable place	indoor, no direct sunlight, no dust, corrosive gas, combustible gas, oil mist, water vapor, water drop or salt, etc
	altitude	derating use if above 1000m, derating 10% for every 1000m increase.
	environment temperature	-10℃~+40℃ (derating use if environment temperature is 40℃~50℃)
	humidity	5%~90% RH, non-condensation
	store temperature	-40℃~+70℃
	vibration	less than 5.9m/s(0.6g)

EXCELLENT PERFORMANCE

Compatibility drive:

Applicable to asynchronous motor, synchronous motor and single motor



Adaptive vector control

Vector performance, VF convenience. The motor parameters are not sensitive and do not need self-learning.

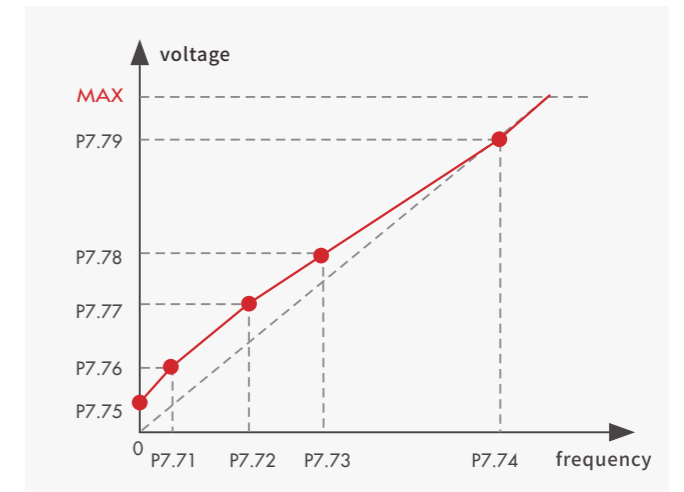

Wide range vector control

Frequency range 0-1000Hz, applicable to more motors, and ensures high performance when running with high speed

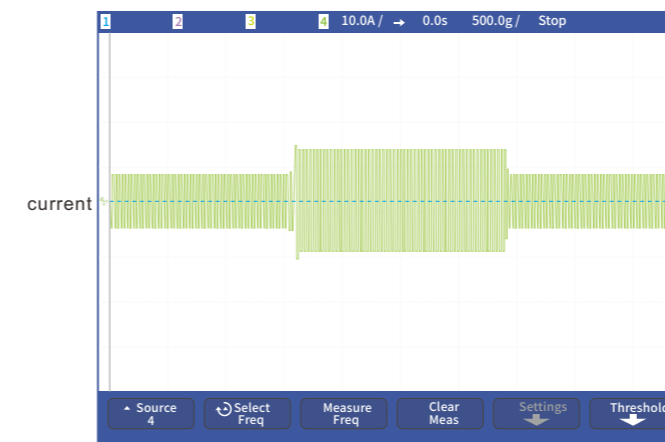

High carrier frequency

Max. 16Hz, motor can work more quietly.

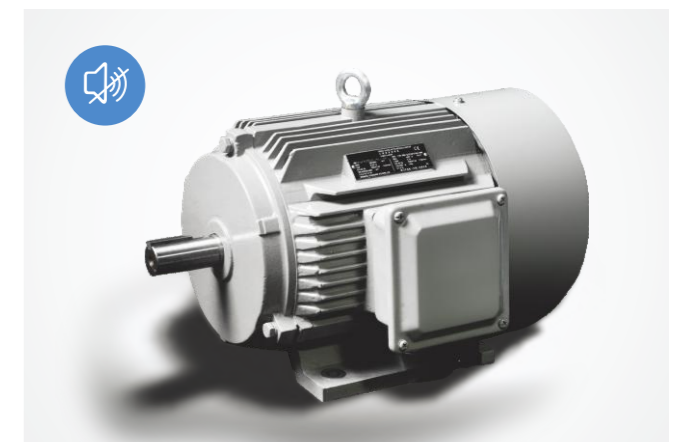

Fast current control

High dynamic response speed (15mS), fast start-up speed, small speed fluctuation.

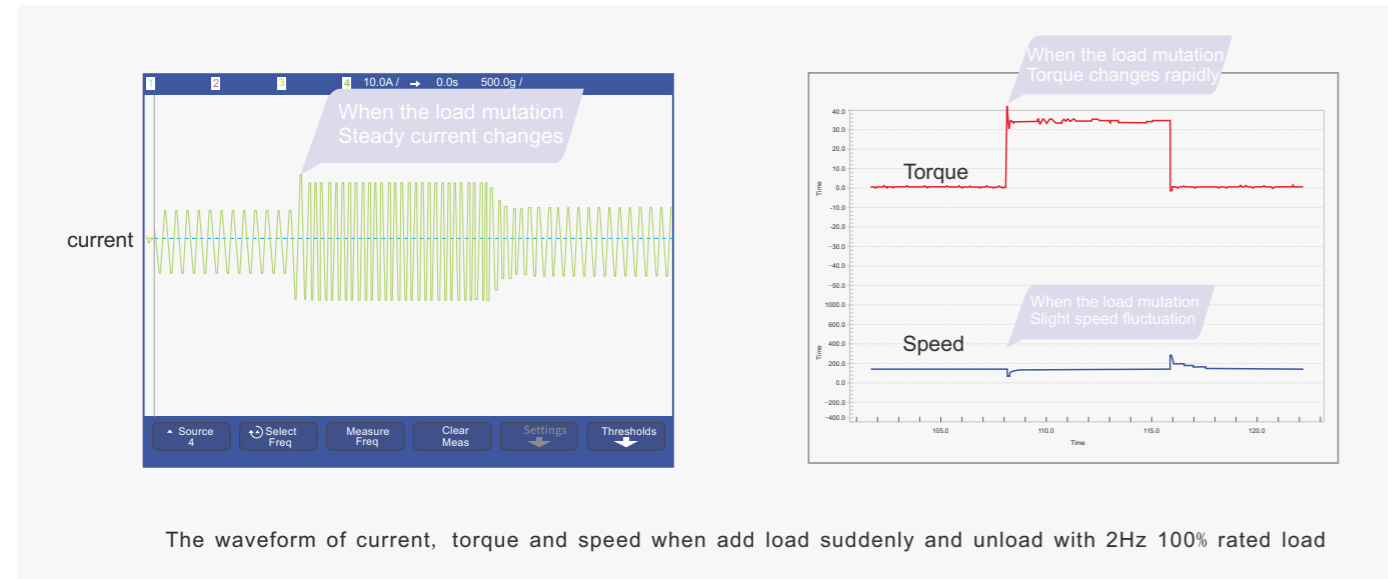

POWERFUL FUNCTION

Easy to operate:

Select terminal source according to the required function, saving the number and type of terminal

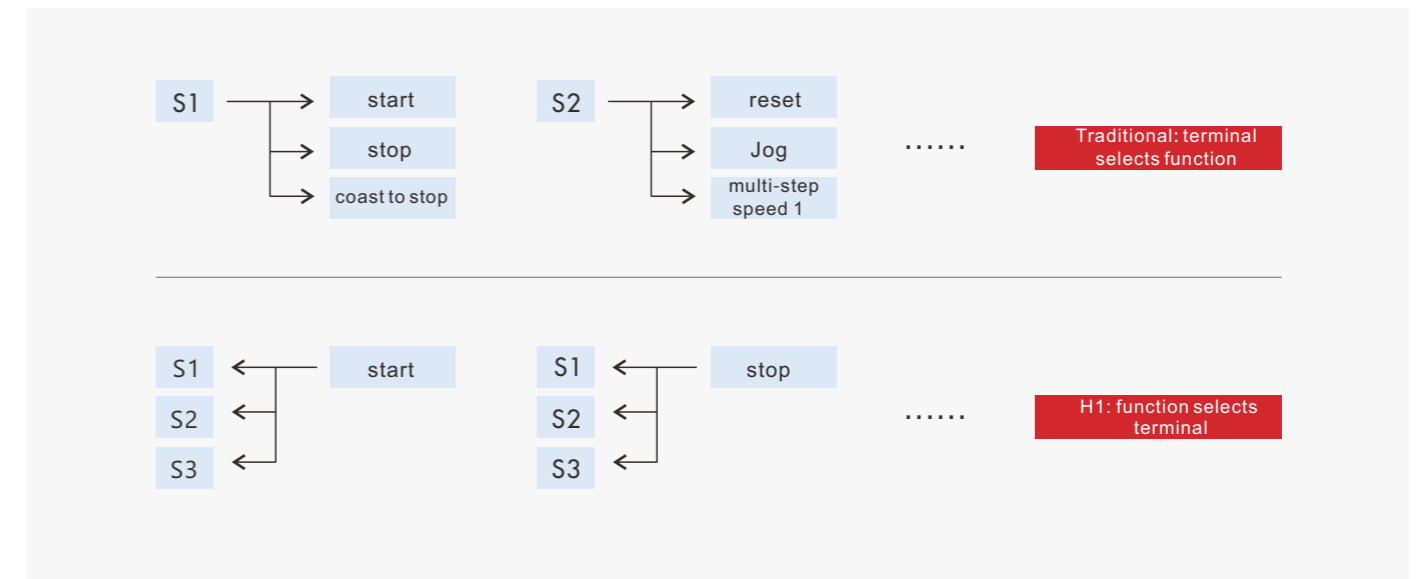

Bus voltage control:

Over-voltage control ensures deceleration at the fastest speed, magnetic flux braking realizes rapid deceleration when there is no braking resistor, and under-voltage control realizes non-stop function when instantaneous power-off.

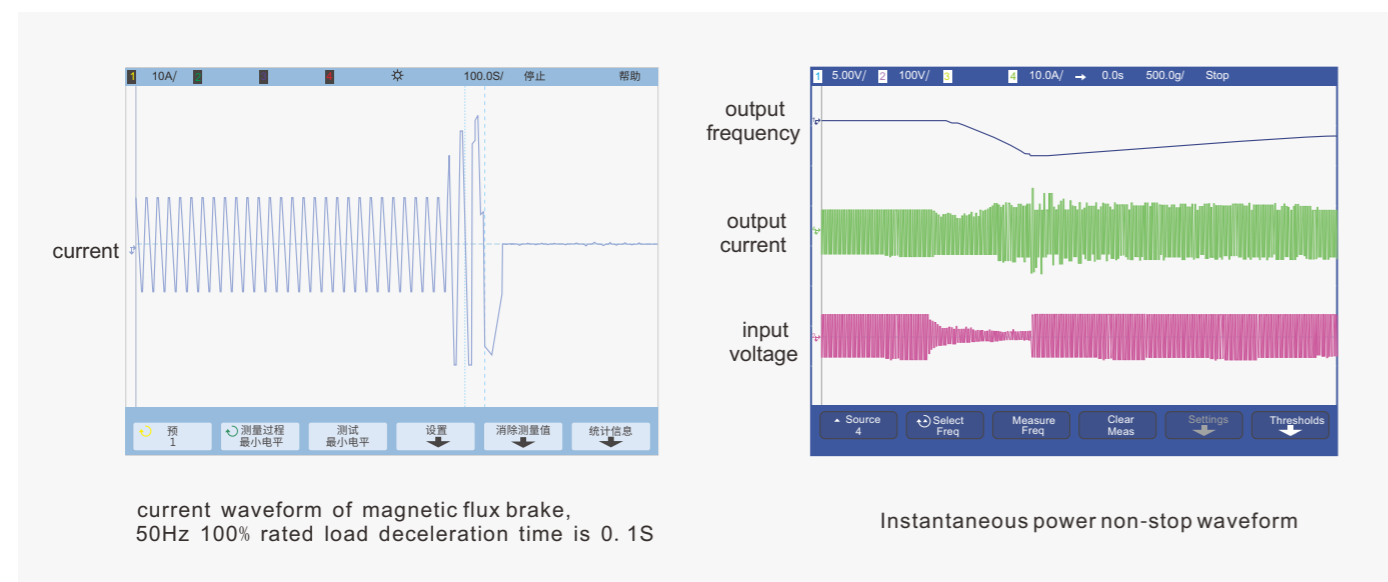

Flexible function:

Flexible combination of setting values and commands, easily adapt to different applications

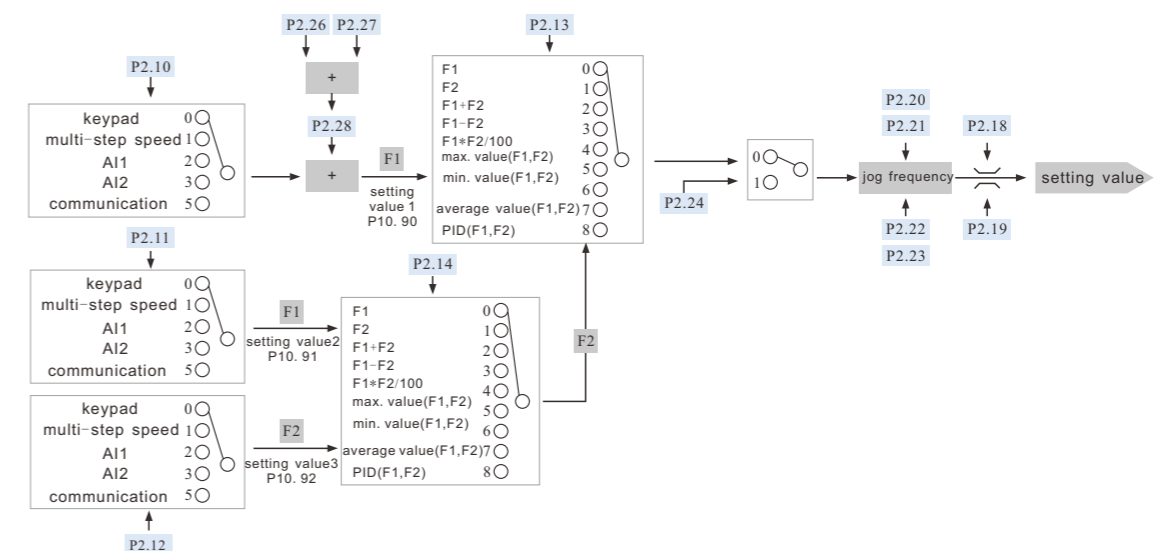

Abundant extended functions:

Provide various key-pad, communication, encoder, IO interface and other extension cards.

External operation panel type



Standard function card

Physical characteristics	Function Card											
	H10001	H10002	H10003	H10004	H10005	H10006	H10007	H10008	H10009	H10010	H10011	H10012
Digital input	4	3	4	8	2	2	3	2	2	4	4	3
Digital output								4	4			
Relay output	1		3	1	1	1	1	1	1	1	1	1
Analog input	1		1		2			1	1	1	1	1
Analog output					2			1	1			
Pulse input						1						
Pulse output						1						
Encoder input							1					
MODBUS	1	1	1	1	1	1	1	1	1	1	1	1
PROFIBUS								1				
CANBUS									1			
Bluetooth										1		
GPRS											1	
STO												1
Typical applications												

Application customization:

Complex application functions can be realized by programming, and customized function call can be realized by application macro

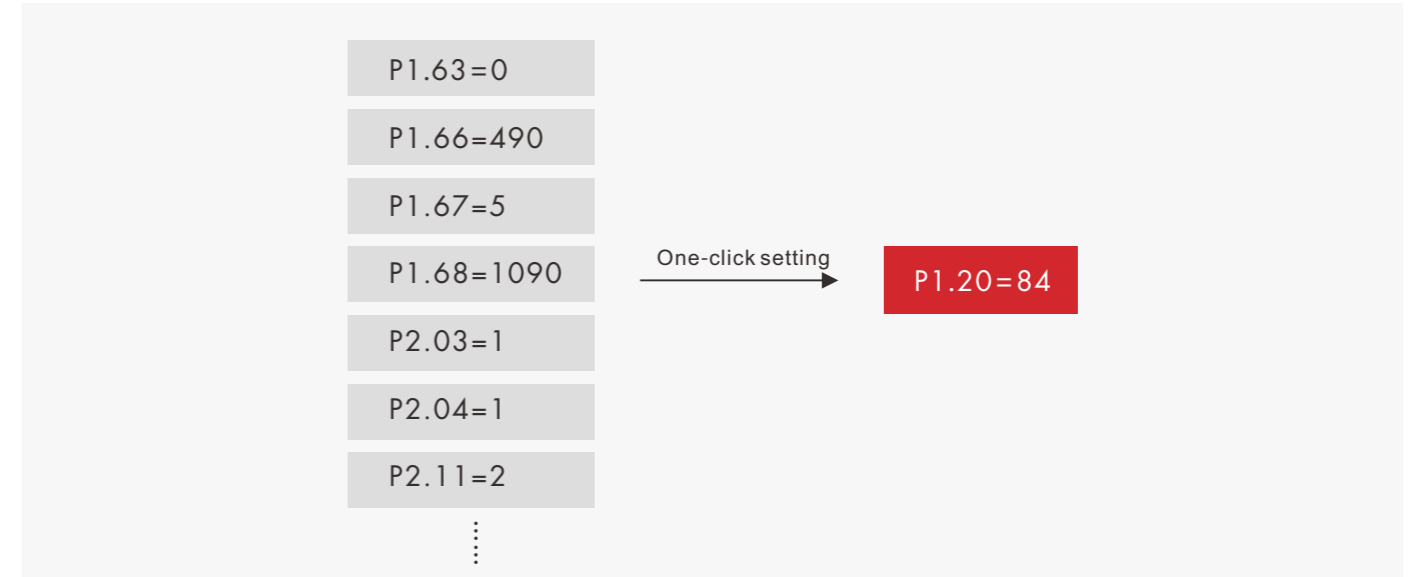

Maintenance tools :

PC upper computer, mobile app and other tools provide perfect monitoring, configuration, optimization and diagnosis services



SOLID HARDWARE

Independent air duct:

No forced wind flows through the components, improving environmental adaptability.



Fast and tight protection:

Short circuit fault, input / output phase loss, overload, leakage, etc., fully protect the inverter and motor.

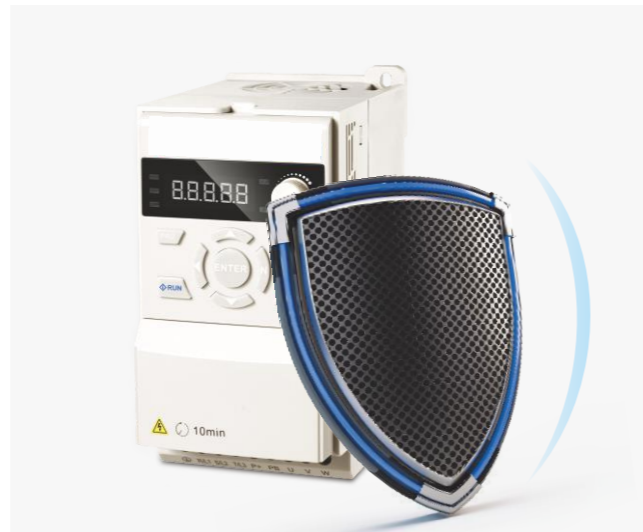

Integrated design:

Reduce the number of boards and flying wires, eliminate potential fault points with the greatest extent, and maximize performance the electrical and EMC with high-efficient.

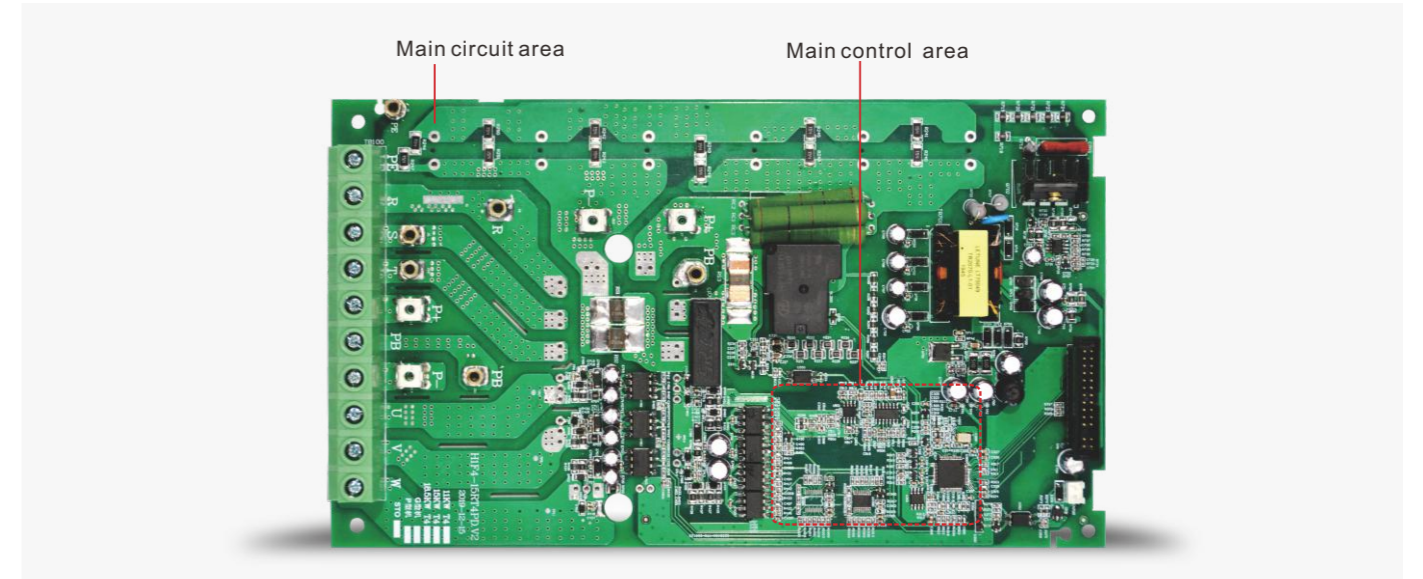

Delicate heat dissipation design:

Compact size and easy installation.

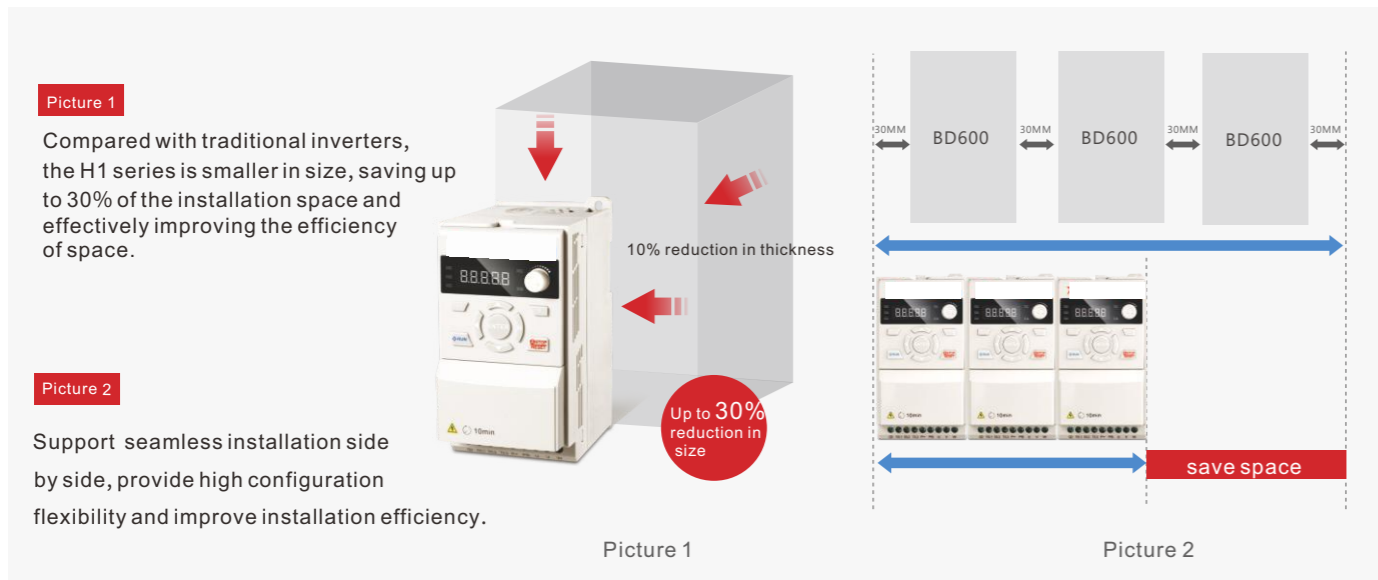

Customization:

According to industry customization, remove redundant functions, cost is more reasonable, and quality is more stable.

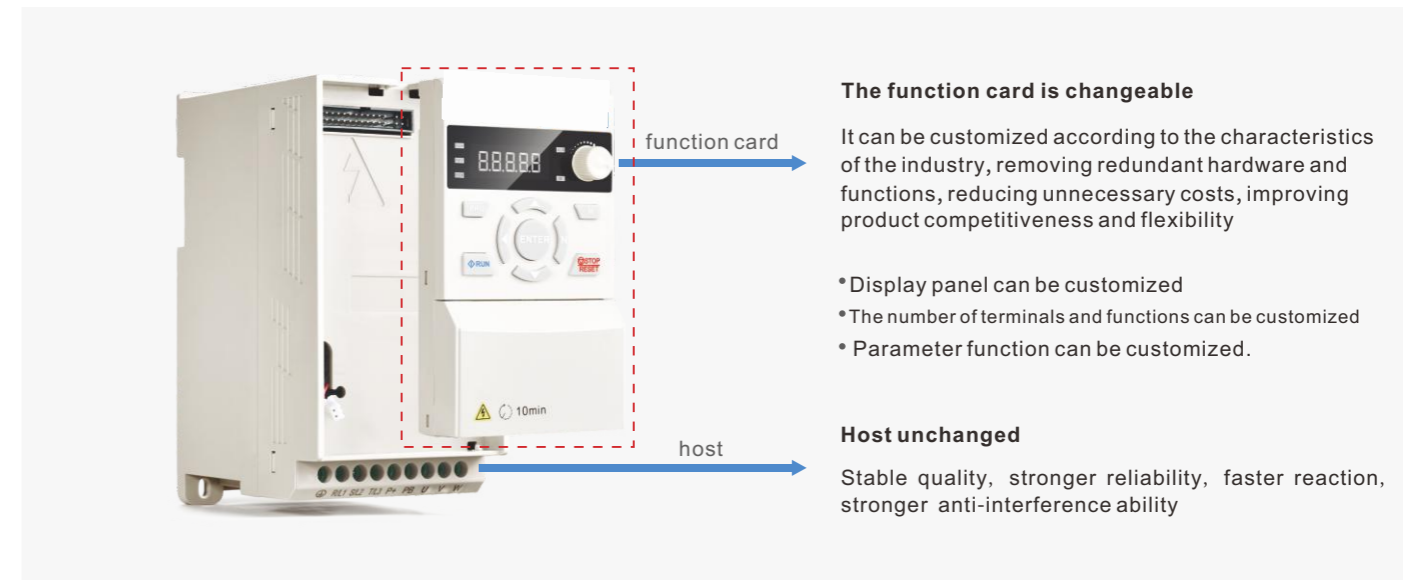



CONNECTION MODE

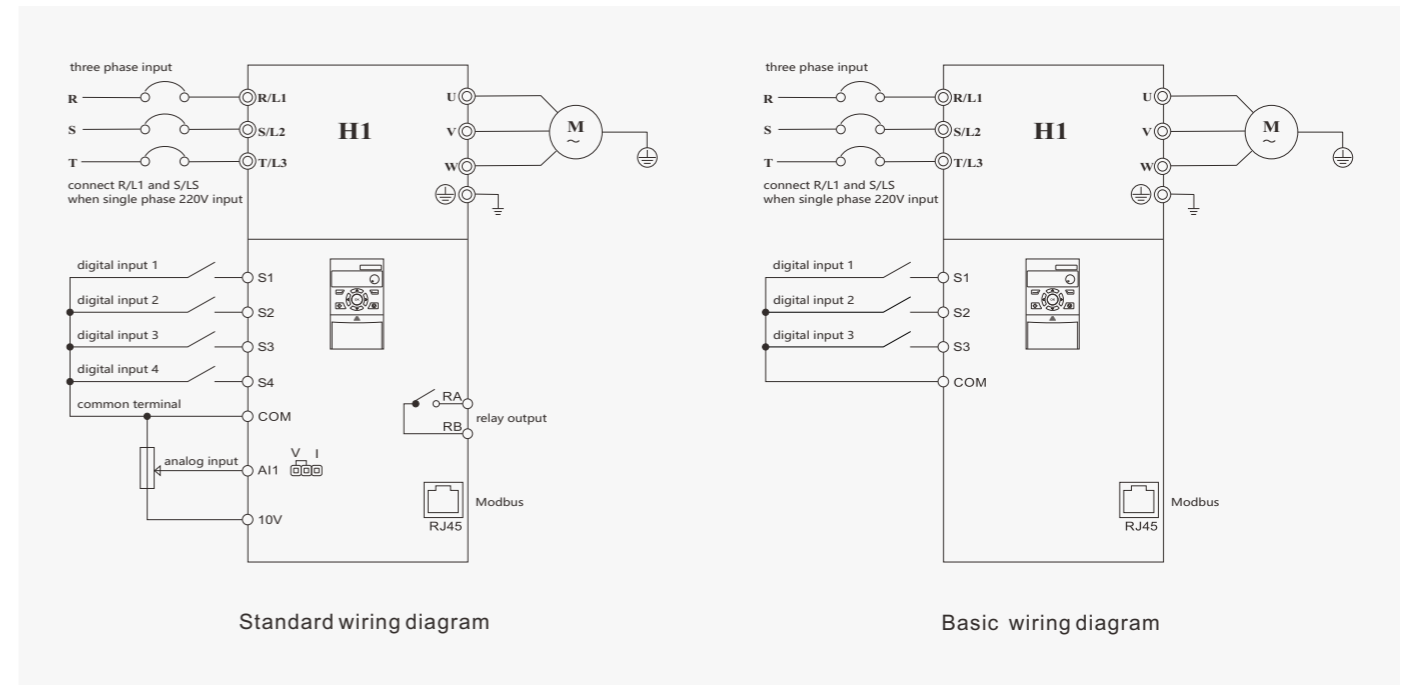

SOME APPLICATIONS

HiTEK F100 series inverter is widely used in textile machine, packing machine, carving machine, printing machine, solar water pump, food machinery, woodworking machinery, water pump fan and ceramic machinery, providing better solutions

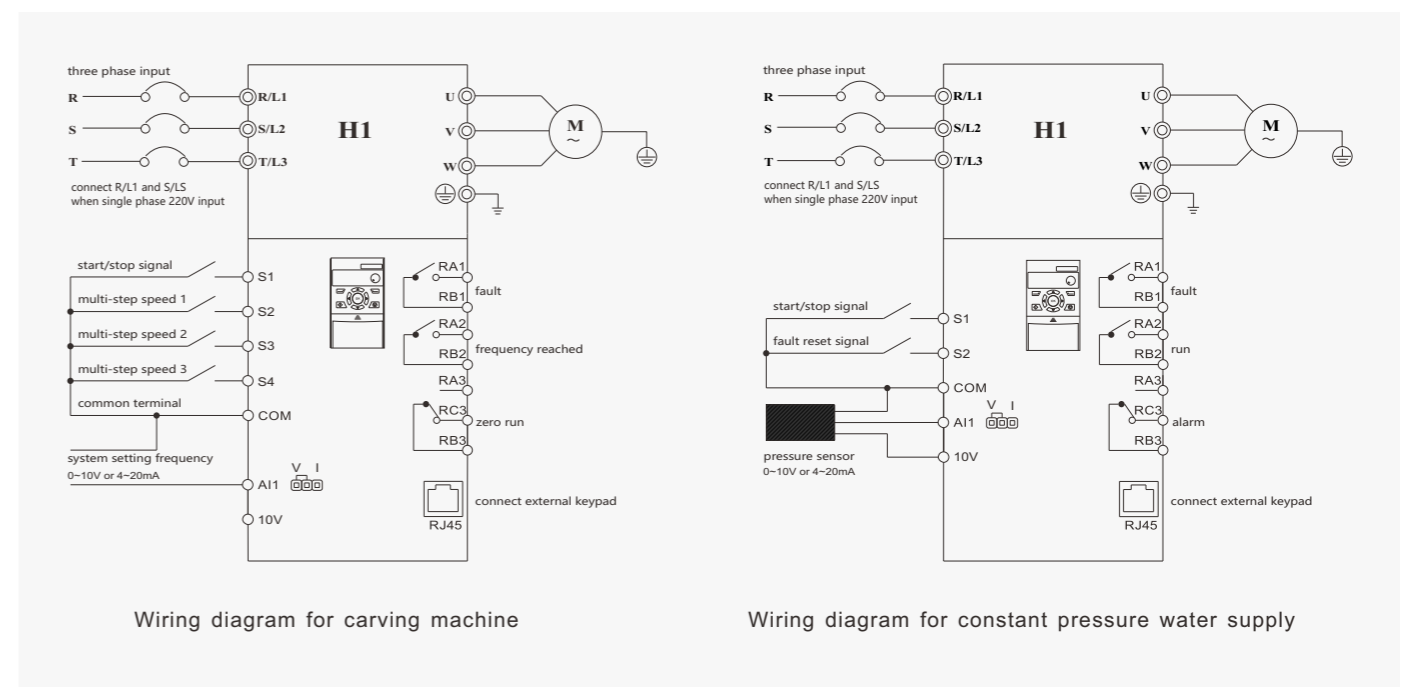
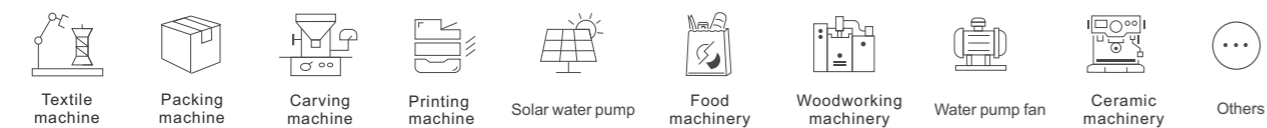

NOMENCLATURE AND DIMENSIONS

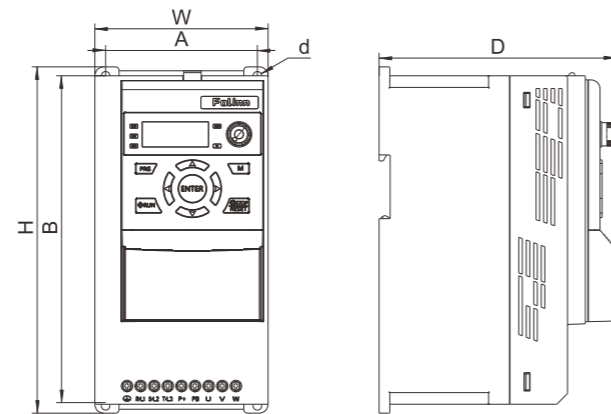
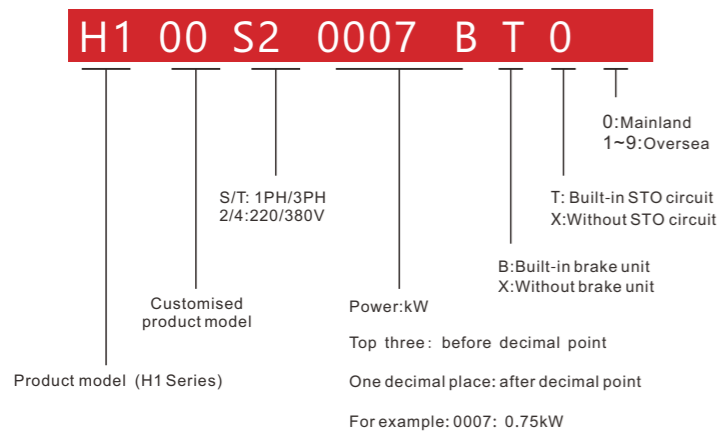

TECHNICAL PARAMETERS

Frame No.	Dimensions(mm)					
	W(Width)	H(Height)	D(Depth)	A	B	d
F1	85	170	124	67.3	158	5
F2	97	194	133	85	184	5
F3	126	237	147	112	223	5
F4	168	298	160	154	283	6
F5	198	355	177	183	338	6

Models and specifications

Frame No.	Models	Input voltage	Input current(A)	Power(KW)	Output current(A)	Adaptive motor(KW)
F1	H100S20007BX0	1PH 220V	8.2	0.75	5.0	0.75
	H100S20015BX0	1PH 220V	14.0	1.5	7.0	1.5
F2	H100T20022BX0	1PH 220V	23.0	2.2	12.5	2.2
		3PH 220V	13.5			
F3	H100T20037BX0	1PH 220V	38.6	3.7	15.2	3.7
		3PH 220V	16.5			
F1	H100T40007BX0	3PH 380V	4.0	0.75	3.0	0.75
		H100T40015BX0	3PH 380V	5.8	1.5	4.5
F2	H100T40022BX0	3PH 380V	6.5	2.2	5.6	2.2
		H100T40040BX0	3PH 380V	12.6	4.0	10.5
F3	H100T40055BX0	3PH 380V	16	5.5	14	5.5
		H100T40075BX0	3PH 380V	21	7.5	19
F4	H100T40110BX0	3PH 380V	28	11	26	11
		H100T40150BX0	3PH 380V	36	15	33
F5	H100T40185BX0	3PH 380V	42	18.5	40	18.5
		H100T40220BX0	3PH 380V	48	22	46