



MS-1

稱重傳感器 LOAD CELL

材質：合金鋼 不銹鋼
Materials: Alloy Steel Stainless Steel

S type load cell, tension and compression
Good output symmetry, compact structure, simple to install, full range of capacities
Suitable for electromechanical scale, crane scale, hopper scale and various special scales

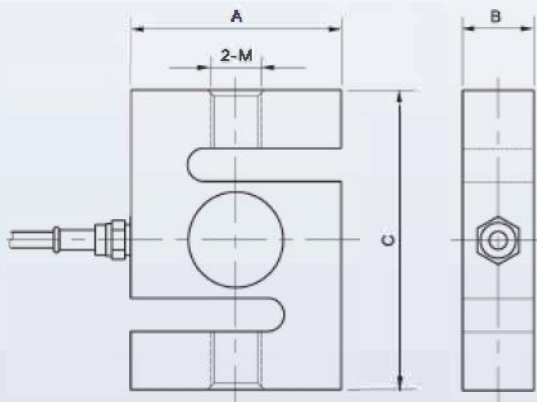

主要外形尺寸

Main Dimensions and Accessories

量程 Capacity		尺寸 Size mm			螺紋 Thread	
Klb	kg	A	B	C	公制 mm	英制 inch
0.025-0.15	5-50	51.0	13.0	64.0	M8X1.25	1/4-28
0.2-1.5	100-500	51.0	19.1	76.0	M12X1.75	1/2-20
2-4	1-2t	54.0	25.4	76.0	M12X1.75	1/2-20
5-10	2.5-5t	76.0	25.4	108.0	M18X1.5	3/4-16
15	7.5t	100.0	32.0	140.0	M24X2	1-14
20	10t	126.0	50.0	178.0	M30X2	1 1/4 -12
30-40	15-20t	140.0	60.0	188.0	M39X2	1 1/2 -12

主要技術指標 Specifications

◆靈敏度 Rated Output(mV/V)	2.00±0.010 3.00±0.010
◆非線性 Nonlinearity	±0.02%FS
◆滯后 Hysteresis	±0.02%FS
◆重複性 Repeatability	±0.01%FS
◆蠕變 Creep(30minutes)	±0.02%FS
◆零點輸出 Zero Balance	±1.00%FS
◆零點溫度係數 Temperature Effect on Zero	±0.02%FS/10°C
◆額定輸出溫度係數 Temperature Effect on Output	±0.02%FS/10°C
◆輸入電阻 Input Resistance(Ω)	385±10
◆輸出電阻 Output Resistance(Ω)	350±3
◆絕緣電阻 Insulation Resistance	≥5000MΩ
◆供橋電壓 Excitation Voltage	10V(DC/AC)
◆溫度補償範圍 Compensated Temperature Range	-10°C→+50°C
◆使用溫度範圍 Operating Temperature Range	-20°C→+60°C
◆允許過載負荷 Safe Overload	120%FS
◆連接電纜 Cable	Φ5.4×5m

連接方法 Cable Color Code

Input: Red(+), Black(-);
輸入: 紅(+), 黑(-);
Output: Green(+), White(-);
輸出: 綠(+), 白(-)